



*Flight
Instructor's
Guide*

Flight Instructor's Guide

Civil Aviation Authority of New Zealand

Revised June 2003

Available from 0800 GET RULES (0800 438 785)

The Theory	1
Introduction	1
Information Processing	1
Definition of Learning	2
Characteristics of Learning	2
Chapter 1—Learning theory	5
Learning components	5
How adults learn	6
Perception	6
Insights	8
Motivation	8
Levels of learning	9
Learning a skill	10
Transfer of learning	13
Forgetting and retention – theories of forgetting	13
Chapter 2—Human behaviour	15
Human needs	15
Defence mechanisms	17
The instructor's role in human relations	17
Chapter 3—Effective communication	19
Basic elements of the communication process	19
The source	19
Symbols	20
Receiver	20
Barriers to effective communication	20
Lack of a common core of experience	21
Confusion between the symbol and the thing symbolised	21
Use of abstractions	21
Chapter 4—The teaching process	23
Preparation	23
Presentation	25
Application	25
Review and evaluation	25
Chapter 5—Teaching methods	27
Organising material	27
Lecture method	29
Guided discussion method	32
Demonstration-performance method	36
Programmed instruction	37
Chapter 6—Evaluation	39
Observations	39
Oral Questioning	40
Written Tests	42
Effective Question Writing	48
Principles of Effective Question Writing	48
Performance Tests	48
Chapter 7—Instructional aids	51
Reasons for using them	51
Guidelines for their use	51
Types	52
Computer-based instruction	54
Future developments	54
Chapter 8—Role modelling	55
Professionalism	55
Sincerity	55
Personal appearance and habits	55
Safety and accident prevention	56
Self improvement	56

The Lessons **59**

Pre-Flight Briefings	61
-----------------------------	-----------

Taxiing	69
----------------	-----------

Effects of Primary Controls	75
------------------------------------	-----------

Effects of Ancillary Controls	83
--------------------------------------	-----------

Straight-and-Level	89
---------------------------	-----------

Climbing	97
-----------------	-----------

Descending	109
-------------------	------------

Climbing and Descending	115
--------------------------------	------------

Medium Turns	123
---------------------	------------

Basic Stalling	131
-----------------------	------------

Advanced Stalling	141
--------------------------	------------

Circuit – Introduction	149
-------------------------------	------------

Circuit – Considerations	161
---------------------------------	------------

Engine Failure After Takeoff	169
-------------------------------------	------------

Flapless Circuit	179
-------------------------	------------

Crosswind Circuit	185
--------------------------	------------

The Standard Overhead Join	193
-----------------------------------	------------

Vacating and Joining the Circuit	199
---	------------

Radio Failure	203
----------------------	------------

Forced Landing Without Power – The Pattern	209
---	------------

Forced Landing Without Power – Considerations	221
--	------------

Glide Approach	231
-----------------------	------------

Steep Turns	237
Maximum Rate Turns	245
Wing-Drop Stalling	253
Compass Turns	259
Short-Field Takeoff	269
Short-Field Landing	277
Low Flying – Introduction	285
Low Flying – Consolidation	293
Precautionary Landing	301
Instrument Flying – Introduction	307
Instrument Flying – Limited Panel	315
Instrument Flying – Unusual Attitudes	321
Map-Reading	327
Acknowledgments	335
References	337

Acknowledgements

This Flight Instructor's Guide has been prepared for the Civil Aviation Authority of New Zealand by John Parker (Flight Testing Officer), with the assistance of CAA staff members Michael Tucker and Murray Fowler.

Input on behalf of the Royal New Zealand Aero Club Inc was provided by Robin Porter (Auckland Aero Club), Wayne Harrison (New Plymouth Aero Club), John Penno (Otago Aero Club), and Andrew Buttle (North Shore Aero Club).

On behalf of the Aviation Industry Association of New Zealand Inc Flight Training Division, input was provided by Gordon Vette and Mark Carter (Flightline Aeronautical College), Russell Jenkins (Associated Flying School), and Andy Smith (Nelson Aviation College).

Input from Aviation Services Limited was provided by Paul Collard-Scruby and Alan Daley (Auckland Examiners), Graham Leach (Wellington Examiner), and Peter Dixon (Christchurch Examiner).

Comments were received from Bruce Farquhar (author of a New Zealand student flight training manual, *Airborne – the Complete Pilot*, 1995), and Harold Bennett (friend and consultant to the CAA of New Zealand).

Preparation of the draft copies was carried out by Ted Fletcher, and the pre-flight briefings were primarily drawn from the Ardmore Flying School, with the invaluable computer skills of Michael Berghan.

The total presentation has been overseen by Dr Lynn Hunt (Massey University, School of Aviation).

Where no other reference is cited, this document draws heavily on the information provided in the Australian Civil Aviation and US Federal Aviation Administration Flight Instructor Handbooks, and their permission to reproduce that information is gratefully acknowledged.

This guide is to be used, not in isolation, but in conjunction with the recommended texts and an appropriate course of flight instructor training.

Footnote, June 2003 edition: The above acknowledgements were omitted from the 1999 edition. They appear here substantially as drafted in 1999; persons' places of employment will have since changed in many instances.

The Theory

Introduction

The expert flight instructor is master of many skills and fields of knowledge. **What** is taught demands technical competence in these areas, but **how** the teaching is accomplished depends on your understanding of how people learn and the ability to apply that understanding. The following gives some insights into the learning process and is meant to guide you into areas of further study. Teaching is a rewarding experience, but those rewards are not easily achieved. It is doubtful that anyone has a natural ability to teach or understand how others learn, therefore the professional instructor continues the life-long process of learning not only flying skills but also teaching skills.

It is intended that this section be reviewed regularly so that you gain the most benefit from it. As your experience widens you will need to draw on a wider and wider variety of teaching methods so that you can maximise your student's learning. Refreshing this section should help you remember those teaching methods that you may not use very often.

Information Processing

To understand how a person learns we first need to consider a basic model of information processing¹.

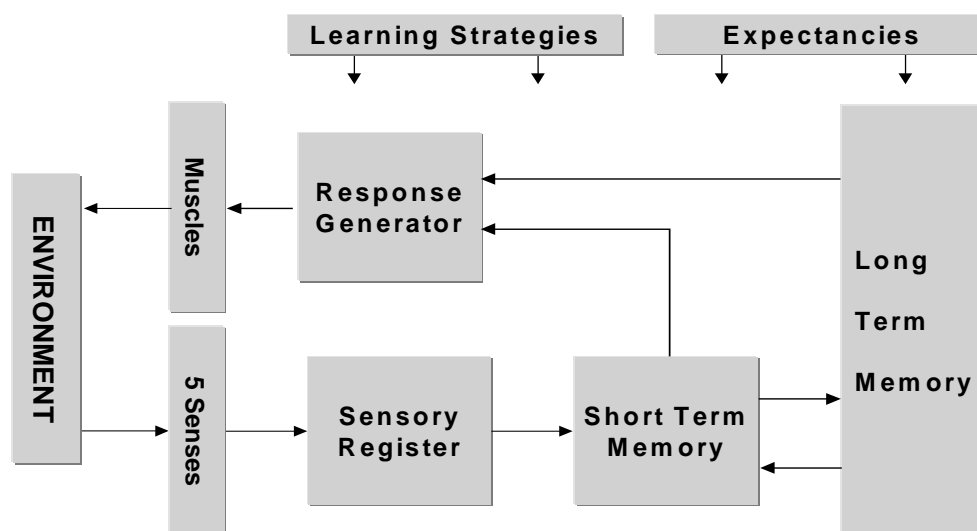

Figure A

The five senses are acted upon by the environment (the cockpit, classroom or instructor) and the information is passed by the nervous system to the sensory register. The information remains in its original form for only a fraction of a second while pattern recognition takes place, giving form and shape to the information.

The information passed to the short-term or working memory, is coded as a concept. For example, the word aeroplane takes on meaning, but information received from long-term memory may modify that concept, say to a jet aeroplane. This re-coded information is passed to long-term memory for storage or is acted upon.

Information from either short-term or long-term memory is passed to the response generator, or decision-maker, and this information is passed through the nervous system to the body's muscles, which act upon the environment.

¹ adapted from Gagne & Driscoll, 1988

This whole process is affected by expectancies. For example, you will probably have had an experience of seeing what you wanted to see, rather than what was actually there. Expectancies affect the way information is perceived, the way it is coded, and the generated response.

The process is further affected by the strategies used to encode the information – learning strategies². For example, the use of mnemonics or mind-mapping to store information can greatly affect later retrieval.

Definition of Learning

To define learning, it is necessary to analyse what happens to the individual. As a result of a learning experience, an individual's way of perceiving, thinking, feeling and doing may change. Therefore, learning can be defined as “a change in behaviour as a result of experience that persists”³. The behaviour can be physical and overt, or it can be intellectual or attitudinal, and therefore not easily seen. Learning occurs continuously throughout a person's lifetime.

Characteristics of Learning

Learning comes from experience

The student can only learn from individual experience. A person's knowledge is a result of experience, and no two people have had identical experiences. Even when observing the same event, two people react differently; they learn different things from it, according to the manner in which the situation affects their individual needs. Previous experience conditions a person to respond to some things and ignore others.

All learning is by experience⁴, but it takes place in different forms and in varying degrees. Some experiences involve the whole person, while others only the ears and memory. You are faced with the problem of providing experiences that are meaningful, varied and appropriate; for example, by repeated drill, students can learn to say a list of words, or by rote they can learn to recite certain principles of flight. However, they can only make them meaningful if they understand them well enough to apply them correctly to real situations. If an experience challenges the learner, requires involvement with feelings, thoughts, memory of past experiences, and physical activity, it is more effective than an experience in which all the learner has to do is commit something to memory⁵.

It seems clear enough that the learning of a physical piloting skill requires experience in performing that skill. However, mental habits are also learned through practice. If students are to use sound judgement and solve problems well, they must have had learning experiences in which they have exercised judgement and applied their knowledge of general principles in the solving of realistic problems⁶.

Learning must have relevance

Each student sees a learning situation from a different viewpoint. Each student's past experience affects readiness to learn. Most people have fairly definite ideas about what they want to achieve. Therefore, each student has specific goals and their needs and attitudes may determine what they learn as much as what you are trying to get them to learn. Students learn

² Wittrock, 1988

³ Gagne & Driscoll, 1988

⁴ Dewey, 1938

⁵ Wittrock, 1988

⁶ McKeachie, 1988

from any activity that tends to further their goals. The effective instructor must discover the student's goals and seek ways to relate new learning to those goals⁷.

Learning outcomes are multiple

If instructors see their objective as being only to train their student's memory and muscles, they underestimate the potential of the teaching situation. Students may learn much that you did not intend, for they did not leave their thinking minds or feelings at home, just because these were not included in your lesson plan. Learning can be classified by type as: verbal, conceptual, perceptual, motor, problem solving and emotional. These divisions are artificial, however. For example, a class learning problem solving may learn by trying to solve real problems. In doing so it is also engaged in **verbal learning** and **sensory perception**. Each student approaches the task with preconceived ideas and feelings, and for many students these ideas change as a result of the experience. The learning process, therefore, may include many types of learning, all taking place at the same time.

In another sense, while learning the subject at hand, students may be learning other things as well. They may be developing attitudes about aviation, good or bad, depending on what they experience. You must always display a professional attitude, regardless of whether or not instruction is actually taking place. This learning is sometimes called **incidental**⁸, but it may have a great impact on the total development of the student.

Learning is an active process

You cannot assume that students remember something just because they were present in the classroom, briefing or aircraft when you taught it. Neither can you assume that the students can apply what they know because they can quote the correct answer from the book. For the students to learn, they must attend to instruction, react and respond by relating information to their knowledge and experience, construct meaning from that interaction, and attribute results to their own effort⁹. If learning is a process of changing behaviour, that process must be inter-active and observable

⁷ Gagne & Driscoll, 1988

⁸ Craik & Lockhart, 1993

⁹ Wittrock, 1988

Chapter 1—Learning theory

Learning components

Psychologists over the years have proposed various theories on learning, and from these we can gain an insight into the learning process. Listed below are some of the most widely accepted learning components.

Relevance

Individuals learn best when they see a reason for learning. If students have a clear objective, and a well defined reason for learning, they make rapid progress. You must explain the relevance of each lesson; for example, why must the student recognise the symptoms of the approaching stall?

Repetition

Those things most often repeated are best remembered¹⁰. Every time practice occurs, learning continues. Students do not learn crosswind landings from one instructional flight. You must provide opportunities for practice and must see that this process is directed toward a goal.

Rewards, reinforcement or conditioning

“One of the most powerful forms of reward available to the instructor is praise”¹¹. Learning is strengthened when accompanied by a pleasant or satisfying feeling and weakened when associated with an unpleasant one. An experience that produces feelings of defeat, frustration, anger, confusion or futility is unpleasant for the student. If, for example, an instructor attempts to teach landings during the first flight, the student is likely to feel overwhelmed. Impressing the student with a difficult manoeuvre can make the later teaching task difficult. It is better to tell students that a manoeuvre or problem, although difficult, is within their capabilities to perform or understand. Whatever the learning situation, it should affect the student positively and give them a feeling of satisfaction.

Primacy

What is taught first, often creates a strong, almost unshakeable impression. Therefore what is taught, and what is learnt, must be right the first time. Un-teaching is more difficult than teaching.

Intensity or arousal

A vivid, dramatic or exciting learning experience teaches more than does a routine or boring experience. This implies that the student will learn more from the real thing. In contrast to in-flight instruction, the classroom limits the amount of realism that can be brought into the teaching. Instructors should use imagination in the briefing. Photographs, mock-ups, and audio-visual aids can add vividness to classroom instruction.

¹⁰ Wickelgren, 1981

¹¹ Elshaw, 1993, p.265

Recency

The things most recently learned are best remembered. Instructors recognise recency when they carefully plan a summary of their pre-flight briefing or post-flight critique. You must repeat, restate or re-emphasise important points at the end of the lesson.

How adults learn

One view of learning that is of particular importance to the flight instructor, is that proposed by M.S. Knowles on how adults should be treated differently from children, based on their psychological differences.

- Children **need to know** what the teacher teaches if they want to pass.
- The child's **self-concept** is one of dependence on the teacher.
- The child's past **experience** is of little worth; it is the teacher's experience that matters.
- The child is **ready** to learn when the teacher tells them to learn.
- The child is **orientated** toward subject matter.
- The child is **motivated** to learn by external forces, eg, grades, parents.

As flight instructors deal with adult or early adult education, how these differences affect adult learning is of some importance.

- Adults **need to know why**; they need to see a use for their learning.
- Adults have a **self-concept** of being responsible for their own lives. They resent and resist situations in which they feel others are imposing their wills on them.
- Adults have a greater quantity and quality of **experience**, therefore more emphasis is placed on techniques which use that experience, such as group discussion and simulation exercises.
- Adults become **ready** to learn when they see a need for learning in order to deal with real-life situations.
- Adults learn most effectively when the context is **orientated** so that they can see that the learning will help them deal with tasks or problems.
- Adults are affected by external **motivation**, but they possess a far more powerful internal motivation through job satisfaction or self-esteem.

Recommended Reading

For a fuller explanation of how these factors affect the adult learner, flight instructors are encouraged to read *The Adult Learner: A Neglected Species*. by M.S. Knowles (1988), Chapter 3.

Perception

Initially, all learning comes from perceptions that are directed to the brain by one or more of the five senses. Psychologists have determined that normal individuals acquire about 75% of their knowledge through the sense of sight, 13% through hearing, 6% through touch, 3% through smell and 3% through taste. They have found that learning occurs most rapidly when information is received through more than one sense.

Perception involves more than receiving stimuli from the five senses. Perceptions result when a person gives meaning to sensations. People base their actions on the way they believe things to be, and this will depend on many factors within each person¹². The experienced flight instructor, for example, will interpret engine rough running quite differently to an inexperienced student. Because perceptions are the basis of all learning, some of the factors that affect the perceptual process are discussed below.

Goals and values

Every experience and sensation that is funnelled into the brain is coloured by the individual's own beliefs and value structure. Spectators at a rugby game may 'see' an infraction or foul differently depending on which team they support. The precise kinds of commitments and philosophical outlooks that the student holds are important for you to know, since this knowledge will assist in predicting how the student will interpret experiences and instructions. For example, the student with an interest in crop-dusting will perceive instruction differently from those interested in airlines or helicopters. Motivation is also a product of a person's value structure; those things most highly valued are pursued while those of less importance are not.

Self-concept

A student's self-image, described as 'confident' or 'insecure' has a great influence on the perception process. How a person sees themselves is a powerful factor in learning. The student who attributes success to hard work, and failure to lack of effort, will perform better than a student who attributes success to luck and failure to lack of ability¹³.

Time and opportunity

Learning depends on previous perceptions (experience) and the availability of time to relate new perceptions to the old. Therefore sequence and time available affect learning¹⁴. A student could probably stall an aircraft on the first attempt, regardless of previous experience. But the stall cannot be really learned unless some experience in normal flight has been acquired. Even with such previous experience, time and practice are needed to relate the new sensations and experiences associated with stalls in order to develop a perception of the stall. The length and frequency of an experience affect the learning rate. The training syllabus must provide time and opportunity. As a general guide for ab initio flight instruction little and often is best¹⁵.

The element of threat

Fear adversely affects a student's perception by narrowing their perceptual field. The field of vision is reduced, for example, when an individual is frightened and all perceptual faculties are focused on the thing that has generated fear. Anxiety or worry (milder forms of fear) take up processing space in the working memory and may produce a "deficit in memory"¹⁶, for example, during the initial practice of steep turns, a student may focus attention on the altimeter and completely disregard outside visual references. Anything an instructor does that is interpreted as threatening makes the student less able to accept the experience you are trying to provide. It adversely affects all the student's physical, emotional and mental faculties. Hence the extensive use, in flight instruction, of the follow-me-through exercise. The student gains perception from the feel of control inputs but more importantly in the early stages, the student gains from the elimination of fear. You need to build a climate of

¹² Gagne, 1971

¹³ McCombs, 1988

¹⁴ Gagne & Driscoll, 1988

¹⁵ Reynolds & Glasser, 1964

¹⁶ Gaudry & Spielberger, 1971, p.28

confidence in which the student realises that you will not allow them to put the aircraft into a dangerous situation, and so the student's confidence in performing the manoeuvre grows. Learning is primarily a psychological process. As long as the student feels capable of coping with a situation, each new experience is viewed as a challenge.

Teaching is consistently effective only when those factors that influence perceptions are recognised and taken into account.

Insights

Insights involve the grouping of perceptions into meaningful wholes. To ensure that these occur, it is essential to help the student realise the way each piece relates to all the other pieces of the total pattern of the task to be learned¹⁷.

As an example, in straight-and-level flight, in an aircraft with a fixed-pitch propeller, the rpm will increase when the throttle is opened and decrease when it is closed. Rpm changes, however, can also result from changes in pitch attitude without changes in power setting. Therefore engine rpm, power setting, airspeed and attitude are inter-related. Understanding the way in which each of these factors may affect all of the others, and understanding the way in which a change in any one of them may affect changes in all of the others, is imperative to true learning. This mental relating and grouping of associated perceptions is called insight.

Insights will almost always occur eventually, whether or not instruction is provided. Instruction, however, speeds this learning process by teaching the relationship of perceptions as they occur, thus promoting the development of insights by the student.

It is a major responsibility of the instructor to organise demonstrations, explanations and student practice so that the learner has the opportunity to understand the inter-relationship of experiences.

Pointing out the relationships as they occur, providing a secure and non-threatening environment in which to learn, and helping the student acquire and maintain a favourable self-concept are most important in the learning process.

Motivation

Motivation is the dominant force that governs the student's progress and ability to learn¹⁸. Motivations may be negative or positive, tangible or intangible, or subtle or obvious.

Negative motivations are those which engender fear. They are not characteristically effective in promoting efficient learning.

Positive motivations are provided by the promise or achievement of rewards. These rewards may be personal or social; they may involve financial gain, satisfaction of the self-concept, or public recognition. Some motivations that can be used to advantage by you include the desire for personal gain, the desire for personal security, the gaining of a sense of achievement, the desire for group approval, and the achievement of a favourable self-image.

The desire for personal gain, either the acquisition of things or position, is a basic motivation for all human endeavours. An individual may be motivated to dig a ditch or to design an aircraft solely by the desire for financial gain.

¹⁷ Gagne, 1971

¹⁸ Hawkins, 1993

Students are like all other workers in wanting a tangible return for their efforts. If such motivation is to be effective, they must believe that their efforts will be suitably rewarded. These rewards must be constantly apparent to the student during instruction, whether they are to be financial, self interest or public recognition.

The student may not appreciate why they are learning a particular lesson. If motivation is to be maintained it is important that you ensure the student is aware of the applications of the lesson. This is usually achieved through the verbal introduction to the pre-flight brief. The attractive features of the activity to be learned can provide a powerful motivation. Students are anxious to learn skills that may be used, and if they can be made to understand how each learning task relates to their goals, they will be eager to pursue it.

The desire for personal comfort and security is a motivation that is often inadequately appreciated by instructors. All students want secure, pleasant conditions and states of being. If they recognise that what they are learning may promote this objective, their interest is easier to attract and hold. Insecure and unpleasant training situations retard learning.

Everyone wants to avoid pain and injury. Students are likely to learn actions and operations that they realise may prevent injury. This is especially true when the student knows that the ability to act correctly in an emergency results from adequate learning.

Group approval is a strong motivating force. Every person wants approval of friends and superiors¹⁹. Interest can be stimulated and maintained by building on this natural force. Most students enjoy the feeling of belonging to a group and are interested in attaining prestige among their fellow students.

Every person seeks to establish a favourable self-image. This motivation can best be fostered by you through the introduction of perceptions which are based on facts previously learned and which are easily recognised by the student as achievements in learning. This process builds confidence, and motivation is strengthened as a result.

Positive motivation is essential to learning. Negative motivations in the form of reproof and threats should be avoided with all but the most overconfident and impulsive students.

Slumps in learning are often due to slumps in motivation. Motivation does not remain at a uniform level and may be affected by outside influences, such as physical fitness or inadequate instruction. You must tailor instruction to maintain the highest possible level of motivation and should be alert to detect and counter lapses in motivation.

While the flight instructor must consider the motivation of students, it is also essential for the professional flight instructor to consider their own motivation. “The potential influence of an instructor is so great that it merits a career path and status” of its own, while “the use of flight instruction as a transient position to accumulate the hours needed to progress to an airline position is a hackneyed strategy and an unfortunate syndrome for the industry”²⁰.

Levels of learning

Learning may be accomplished at any of several levels. From the lowest to progressively higher levels of learning, these are:

- **rote learning**, the ability to repeat back something one has been taught without understanding or being able to apply it,

¹⁹ Maslow, 1970

²⁰ Telfer, 1993, p.5

- **understanding** what has been taught,
- **application** of what has been learnt, and
- **correlating** what has been learnt with other things previously learnt.

For example, a flight instructor may tell a beginning student pilot to enter a turn by banking the aircraft with aileron and applying sufficient rudder in the same direction to prevent slip or skid. A student who can repeat these instructions has learned by rote. This will not be very useful to the student if there is no opportunity to make a turn in flight (application) or if the student has no knowledge of the function of the aircraft controls (correlation).

Through instruction on the effect and use of the flight controls and experience in their use in straight-and-level flight, the student can develop these old and new perceptions into an insight on how to make a turn. At this point the student has developed an understanding of the procedure for turning the aircraft in flight. This understanding is basic to effective learning but may not necessarily enable the student to make a correct turn on the first attempt.

When the student understands the procedure for entering a turn and has practised turns until an acceptable level of performance can be consistently demonstrated the student has developed the skill to apply what has been taught.

Learning a skill

Even though the process of learning has many aspects, the purpose of instruction is usually to learn a concept or skill. The process of learning a skill appears to be much the same whether it is a motor (physical) or mental skill. To provide an illustration of motor learning, follow the directions below:

- Write the word learning 15 times with your left hand (or right hand if you are left-handed). Try to improve the speed and quality of your writing.

In the learning task just completed, several principles of motor learning are involved and are discussed below.

Physical skills involve more than muscles

The above exercise contains a practical example of the multifaceted character of learning. It should be obvious that, while a muscular sequence was being learned, other things were happening as well. The perception changed as the sequence became easier. Concepts of how to perform the skill were developed and attitudes were changed²¹.

Motivation

Where there is a desire to learn, rapid progress in improving the skill will normally occur²². Conversely, where the desire to learn or improve is missing, little progress is made. In the exercise above, it is unlikely that any improvement occurred unless there was a clear intention to improve. To improve, one must not only recognise mistakes, but also make an effort to correct them. The person who lacks the desire to improve is not likely to make the effort and consequently will continue to practice errors.

²¹ Gagne & Driscoll, 1988

²² Gagne & Driscoll, 1988

Patterns to follow

The best way to prepare the student to perform a task is to provide a clear, step-by-step example²³. Therefore all exercises start with a demonstration. The demonstration is another way of stating the lesson objective – here is what you (the student) will be able to do at the end of this lesson. The demonstration is followed with a step-by-step follow-me-through example.

Perform the skill

Since you have now experienced writing a word with the wrong hand, consider how difficult it would be to tell someone else how to do it. Demonstrating how to do it will not result in a person learning the skill. Obviously practice is necessary²⁴. As the student gains proficiency in a skill, verbal instructions mean more. Whereas a long detailed explanation is confusing to the student during early practice, comments are more meaningful and useful after the skill has been partially mastered.

Knowledge of results

In learning some simple skills, students can discover their own errors quite easily. In learning others, such as complex flight manoeuvres, mistakes are not always apparent. Or the learner may know something is wrong but not know how to correct it. In either case, you provide a helpful and often critical function in making certain that the student is aware of their progress. They should be told as soon after the performance as possible²⁵, for they should not be allowed to practice mistakes. It is more difficult to un-learn a mistake and then learn it correctly, than it is to learn correctly in the first place. It is also important for students to know when they are right.

Progress follows a pattern

The experience of learning to write with the wrong hand probably confirmed what has been consistently demonstrated in laboratory experiments on skill learning. The first trials are slow and coordination is lacking. Mistakes are frequent, but each trial provides clues for improvement in subsequent trials. The learner modifies different aspects of the skill, how to hold the pencil, how to execute finger and hand movements. Skill learning usually follows the same pattern²⁶.

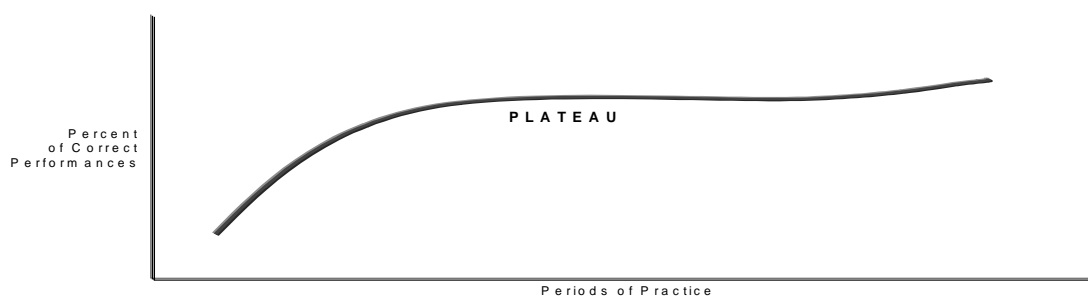

Figure 1.1

Figure 1.1 shows a typical progress pattern. There is rapid improvement in the early trials, then the curve levels off and may stay level for significant periods of effort. Further improvement may seem unlikely. Such a development is a learning plateau, and it may signify any of a number of conditions. The learner may have reached capability limits, may be

²³ Gagne & Driscoll, 1988

²⁴ Gagne & Driscoll, 1988

²⁵ Gagne & Driscoll, 1988

²⁶ Gagne & Glaser, 1987

consolidating a level of skill, may have their interest wane, or may need a more efficient method for increasing progress. Keep in mind that the apparent lack of increasing proficiency does not necessarily mean that learning has ceased²⁷. In learning motor skills, a levelling off process or plateau is normal and should be expected after an initial period of rapid improvement. This situation may cause impatience in the student; to avert discouragement, you should prepare them for this situation.

Duration and organisation of lessons

In planning for student performance, a primary consideration is the length of time devoted to practice. A beginning student reaches a point where additional practice is not only unproductive but may be harmful. When this point is reached, errors increase and motivation declines. The skilful instructor ends the learning experience before this point is reached. As a guide, when the basics of the manoeuvre have been achieved, it's time to end the lesson. For example, in the initial basic stall, when the student performs the actions of control column forward centrally and then full power, the basics of the manoeuvre have been achieved. It is for future lessons to build on this success, ie, aiming for coordination of control column and power, keeping straight and minimising height loss. As a student gains experience, longer periods of practice are profitable.

Evaluation versus critique

If an instructor were to evaluate the fifteenth writing of the word learning, only limited help could be given toward further improvement. You could judge whether the written word was legible, evaluate it against some standard, or perhaps assign it a grade. None of these would be very useful to a beginning student. The student could profit, however, by having someone watch the performance and critique it constructively to help eliminate errors. In the initial stages, practical suggestions are more valuable to the student than a grade.

As the instructor will not always be in the aircraft to give a judgement, self critique should be encouraged as a learning goal for the student.

Visualisation or imagery

“Research on motor skill learning has provided evidence for using mental practice”²⁸. If you were to visualise yourself raising an arm out to the side, it would be possible to monitor activity in the deltoid muscles even though no physical movement had occurred. Imagery therefore has the effect of priming the appropriate muscles for subsequent physical action. The messages passed to the brain by the muscular system during visualisation are also retained in the memory. This means that physical skills can be improved even when they are only practised in the mind. The use of handouts and questionnaires on completion of the lesson can aid the student in reliving the experience in their mind.

Application of skill

The final and critical problem is use. Can the student use what has been learned? Two conditions must be present: (1) The student must learn the skill so well that it becomes easy, even habitual, to perform. (2) The student must recognise the types of situations where it is appropriate to use the skill. This second condition involves **transfer of learning**.

²⁷ Fitts & Posner, 1967

²⁸ Gagne & Driscoll, 1988, p.101

Transfer of learning

Transfer of learning is concerned with how well the learnt material is applied in actual situations. For example, the student may have learnt the symptoms of the approaching basic stall and the recovery technique. But are these symptoms recognised and acted upon when observed in a turn?

Transfer cannot occur if the knowledge itself has not been initially mastered.

This points to a need to know a student's past experience and what has already been learned. In lesson planning, instructors should plan for transfer by organising lesson material to build on what the student already knows. Also, each lesson should prepare the student to learn what is to follow.

Recommended reading

Flight instructors are encouraged to read *Essentials of Learning for Instruction* by R.M. Gagne' and M.P. Driscoll (2nd ed.) (1988).

In addition two extramural (correspondence) papers offered by Massey University, Private Bag 11-222, Palmerston North are recommended to the novice instructor. These are:

90.107 Improving Human Performance; and

90.217 Instruction and Learning in Aviation.

Forgetting and retention – theories of forgetting

Why people forget may point the way to helping them remember.

Disuse

A person forgets those things that are not used. But the explanation is not that simple. Experimental studies show, for example, that a hypnotised person can describe specific details of an event that would normally be beyond recall. Apparently the memory is there, locked in the recesses of the mind. The difficulty is summoning it up to consciousness²⁹.

Interference

From experiments, two conclusions about interference can be drawn:

- Closely similar material seems to interfere with memory more than dissimilar material.
- Material not well learned suffers most from interference³⁰.

Repression

Repression is the submersion of ideas into the unconscious mind. Material that is unpleasant or produces anxiety may be treated this way, but not intentionally. It is subconscious and protective. This type of forgetting is rare in aviation instruction.

Retention of learning

When a person forgets something it is not lost; rather it is unavailable for recall. Hunt & Poltrock offer the analogy of books in a library that are never removed from the shelves,

²⁹ Gagne, 1971

³⁰ Ausubel, 1968

whereas the index cards may be lost. Your problem then, is how to make certain that the student's learning is always available for recall. The following suggestions can help.

Teach thoroughly and with relevance. Material thoroughly learned is highly resistant to forgetting. Meaningful learning builds patterns of relationships in the student's consciousness. Whereas rote learning is superficial and is not easily retained, meaningful learning goes deep because it involves principles and concepts anchored in the student's own experience.

Long-term memory is enhanced if information is well encoded, put into several different files by being explained in different ways and thus well cross-indexed (association). Retention can be assisted by stimulation of interest.

Principles

The following are five significant principles that are generally accepted as having a direct application to remembering:

Praise

Responses that give a pleasurable return tend to be repeated. Absence of praise or recognition makes recall less likely.

Association

Each bit of information or action, which is associated with something already known by the student, tends to facilitate later recall.

Favourable attitudes

People learn and remember only what they wish to know. Without motivation there is little chance for recall. The most effective motivations are internal, based on positive or rewarding objectives.

Multiple senses

Although we generally receive what we learn through the eyes and ears, other senses also contribute to most perceptions. When several senses respond together, fuller understanding and a greater chance of recall is achieved.

Repetition

Each repetition gives the student an opportunity to gain a clearer and more accurate perception of the subject to be learned, but mere repetition does not guarantee retention. Practice gives an opportunity for learning but does not cause it. Three or four repetitions provide the maximum effect, after which the rate of learning and probability of retention fall off rapidly

Chapter 2—Human behaviour

By definition, learning is – a change of behaviour resulting from experience that persists. To successfully accomplish the task of helping to bring about this change, you must know why human beings act the way they do. Knowledge of basic human needs and defence mechanisms will aid you in organising student activities and in promoting a climate conducive to learning.

The relationship between you and the student has a profound impact on how much, and what, the student learns. Consider your own experiences with your first flight instructor. You probably thought your instructor was the best, and you probably strove to emulate and please your instructor. The power and impact of role modelling **must not** be underestimated. The instructor directs and controls the student's behaviour, guiding them toward their goals, by creating an environment that enables the student to help themselves.

To students, the instructor is a role model, a symbol of authority. Students expect you to exercise certain controls, and they recognise and submit to authority as a valid means of control. The controls the instructor exercises – how much – how far – to what degree – should be based on generalisations of motivated human nature.

- Physical and mental effort in work is as natural as play. Work may be a source of satisfaction and, if so, will be performed voluntarily.
- A human being will exercise self-direction and self-control in the pursuit of goals to which they have committed themselves.
- Commitment to a goal relates directly to the perceived reward for achievement, the most significant of which is satisfaction of ego.
- Shirking responsibility and lack of ambition are not inherent in human nature. They are usually the consequence of experience.
- The capacity to exercise a relatively high degree of imagination, ingenuity and creativity in the solution of common problems is widely, not narrowly, distributed in the population.
- Under the conditions of modern life, the intellectual potential of the average human being is only partially used.

Your ingenuity must be used in discovering how to realise the potential of the student. The responsibility rests squarely on you. If the student is perceived as lazy, indifferent, unresponsive, uncooperative or antagonistic, the cause may lie in your methods of control. The raw material is there, and the shaping and directing of it lies in the hands of those who have the responsibility of controlling it.

A productive relationship with the student depends on your knowledge of students, as human beings and of the needs, drives and desires they continually try to satisfy in one way or another.

Human needs

The needs of students, and of all humans, are given labels by psychologists and are generally organised in a series of levels. The 'pyramid of human needs' has been suggested by Abraham Maslow.

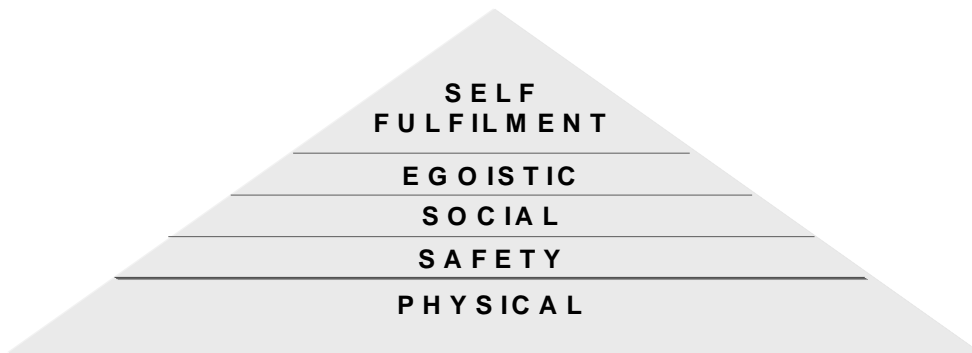

Figure 2.1

Physical needs

Individuals are first concerned with their need for food, rest, exercise and protection from the elements. Until these needs are satisfied to a reasonable degree, they cannot concentrate on learning or self-expression.

Once a need is satisfied, it no longer provides motivation. Therefore each individual strives to satisfy the needs of the next higher level.

Safety needs

Protection from danger, threat or deprivation are called safety or security needs. These needs, as perceived by the student, are real and will affect student behaviour.

Social needs

If individuals are physically comfortable and have no fear for their safety, their social needs then become the prime influence on their behaviour. These needs are to belong, to associate, and to give and receive friendship and love. Many studies have demonstrated that a tightly knit, cohesive group, under proper conditions, will be more effective than an equal number of separate individuals. As students are usually separated from normal surroundings, their need for association and for belonging will be more pronounced.

Egoistic needs

The egoistic needs will usually have a direct influence on the student-instructor relationship. These needs are two kinds:

- Those that relate to self-esteem through self-confidence, independence, achievement, competence and knowledge.
- Those that relate to reputation through status, recognition, appreciation and the deserved respect of peers.

Self-fulfilment needs

At the apex of the hierarchy of human needs are those for self-fulfilment, for realising your own potential, for continued development, and for being creative in the broadest sense. This need of a student should offer the greatest challenge to you. Aiding another in realising self-fulfilment is probably the most worthwhile accomplishment an instructor can achieve.

Defence mechanisms

Certain behaviour patterns are called defence mechanisms because they are subconscious defences against unpleasant situations. People use defences to soften feelings of failure, to alleviate feelings of guilt, and to protect feelings of personal worth and adequacy.

Although defence mechanisms can serve a useful purpose, they can also be hindrances. Because they involve some self-deception and distortion of reality, defence mechanisms do not solve problems. They alleviate symptoms, not causes. Common defence mechanisms are **rationalisation, flight, aggression** and **resignation**.

Rationalisation

If students cannot accept the real reasons for their behaviour, they may rationalise. This device permits them to substitute excuses for reasons. In addition, they can make those excuses plausible and acceptable to themselves. Rationalisation is a subconscious technique for justifying actions that otherwise would be unacceptable.

Flight

Students often escape from frustrating situations by fleeing, either physically or mentally. To flee physically, students may develop ailments that give them satisfactory excuses for removing themselves from frustration. More frequent is mental fleeing through daydreaming. Mental fleeing provides a simple and satisfying escape from problems. If students get sufficient satisfaction from daydreaming they may stop trying to achieve their goals.

Aggression

Everyone gets angry. Anger is a normal, universal human emotion. In a briefing room, classroom or aircraft, extreme anger is relatively infrequent. Because of social strictures, student aggression is usually subtle. Students may ask irrelevant questions or refuse to participate in class activities.

Resignation

Students may become so frustrated that they lose interest and give up. The most common cause of this takes place when, after completing the early phase of a course without grasping the fundamentals, a student becomes bewildered and lost in the advanced phase. From that point learning is negligible, although the student may go through the motions of participating.

The instructor's role in human relations

To minimise student frustration and achieve good human relations are basic instructor responsibilities.

Keep students motivated

Students gain most from wanting to learn rather than being forced to learn. Often students do not realise how a particular lesson or course can help them reach an important goal. Each lesson must have relevance. When they can see the benefits or purpose of a lesson or course, their enjoyment and their efforts will increase.

Keep students informed

Students feel insecure when they do not know what is expected of them or what is going to happen to them. For example, consider your own feelings before your first basic stall lesson.

Instructors can minimise such feelings of insecurity by telling students what is expected of them and what they can expect, not just the control inputs to use.

Approach students as individuals

When instructors limit their thinking to a group without considering the individuals who make up that group, their effort is directed at an average personality which really fits no one³¹. After giving the same lesson several times, it is easy for you to overlook this aspect. Each individual has a personality which is unique and which should be constantly considered.

Give credit when due

When students do well, they wish their abilities and efforts to be noticed. Otherwise they become frustrated. Praise from you is usually ample reward and provides incentive to do even better. Praise given too freely, however, becomes valueless.

Criticise constructively

Although it is important to give praise and credit when deserved, it is **equally** (not more) important to identify mistakes and failures. However, to tell students that they have made errors and not provide explanations does not help them. Errors cannot be corrected if they are not identified, and if they are not identified they will probably be perpetuated through faulty practice. If the student is briefed on the errors made and is told and shown how to correct them progress and accomplishment can be made.

Be consistent

Students want to please their instructor. Therefore, students have a keen interest in knowing what is required to please you. If the same thing is acceptable one day and not the next, the student becomes confused. Your philosophy and actions must be consistent. This often leads to a desire by the student to fly with only one instructor.

Admit errors

No one, including the students, expects an instructor to be perfect. You can win the respect of students by honestly acknowledging mistakes. If you try to cover up or bluff, the students will often sense it. Such behaviour destroys student confidence in you. If in doubt about some point, you should admit it. You should report back to the student after seeking advice from the supervising instructor, CFI, or recognised texts.

Good human relations promote effective learning.

³¹ Howe, 1987

Chapter 3—Effective communication

Communicating, for an instructor, is an essential skill. Improving communication skills depends on an understanding of the process. In this chapter we look at the elements of the communication process and the barriers to successful communication.

Basic elements of the communication process

Communication takes place when one person transmits ideas or feelings to another person or group. Its effectiveness is measured by the similarity between the idea transmitted and the idea received³².

The basic process of communication is composed of three elements:

- The source – sender, speaker, writer, instructor, transmitter, etc.
- The symbols – words, signs, actions, music, etc.
- The receiver – listener, reader, student, etc.

These elements are interrelated, and that which affects one influences the others. If a listener has difficulty in understanding the symbols a speaker is using and indicates confusion, the speaker may become puzzled and uncertain, losing control of ideas. Communication effectiveness is diminished. On the other hand, when a listener reacts favourably, a speaker is encouraged, and force is added to communication. Communication is a complicated two-way process.

The source

The effectiveness of a person acting in the role of communicator is related to at least three basic factors.

First, their ability to select and use language influences their ability to select meaningful symbols for the listener or reader. For example, if you want to teach Greek it's useful to know the Greek alphabet.

Second, communicators consciously or unconsciously reveal attitudes about themselves, about the ideas they are trying to transmit, and about their receivers. These attitudes must be positive if they are to communicate effectively. They must indicate that they believe their message is important. Communicators must make it clear to their listeners or readers that they believe there is a need to know the ideas presented.

Third, successful communicators speak or write from a broad background. Communicators must exercise great care to make certain they communicate ideas and feelings that are meaningful to their receivers. Often a speaker or writer will depend on a narrow, highly technical or professional background, with its associated vocabulary, which is meaningful only to others of a similar background. **Reliance on technical language to express ideas often impedes effective communication.**

³² Salomon, 1981

Symbols

At its basic level, communication is achieved through the use of simple oral and visual codes. The letters of our alphabet when translated into words are a basic code. Common gestures and facial expressions and body language form another³³. Words and gestures may be projected in isolation, but ideas are communicated only when symbols are combined into meaningful wholes as sentences, paragraphs and chapters. Each part is important for effective communication.

Communicators must carefully select ideas if they are to convey messages which receivers can react to and understand. They must determine which ideas are best suited to starting and concluding the communication, and which ideas clarify, emphasise, define, limit and explain – all of which form the basis for the effective transmission of ideas from source to receiver.

The development of ideas culminates in the choice of medium best suited for transmission. Most frequently, communicators select the channels of hearing and seeing. Occasionally, the channel of feeling, by touching or manipulating, can be used effectively. The most successful communicator, however, uses a variety of channels.

Receiver

Communication succeeds only in relation to the reaction of the receiver.

When the receivers react with understanding and change their behaviour accordingly, then – and only then – has communication been effective³⁴. To understand effective communication, at least three characteristics of receivers must be understood³⁵.

First, the receiver's ability to question and comprehend the ideas that have been transmitted. Communicators can capitalise on this by providing an atmosphere which encourages questioning.

Second, the receiver's attitude, which may be one of resistance, willingness or passive neutrality. Whatever the attitude, communicators must gain the receiver's attention and then retain it. Generally, the more varied the communicative approach the more successful they will be in this respect.

Third, the receiver's background, experience and education define the target at which communication must be aimed. Communicators must assess their receiver's knowledge and use that assessment as a guide for selecting techniques for transmission. The major barriers to effective communication are usually found in this particular area.

Barriers to effective communication

The nature of language and the way it is used often lead to misunderstandings. These misunderstandings stem primarily from three barriers to effective communication:

- Lack of a common core of experience
- Confusion between the symbol and the thing symbolised
- Use of abstractions

³³ Sligo, 1988

³⁴ Tagiuri, 1974

³⁵ Salomon, 1981

Lack of a common core of experience

Probably the greatest single barrier to effective communication is the lack of common experience between communicator and receiver. Communication can be effective only to the extent that the experiences – physical, mental or emotional – of the people concerned are similar³⁶. Words do not transport meanings from speaker to listener in the same manner as a truck carries bricks from one location to another. Words never carry precisely the same meaning from the mind of the communicator to that of the receiver.

Consider your own experience as a communicator. Recall telling someone of your experiences on holiday. Although you tried to describe the experience vividly, you may have felt that the receiver didn't get the full picture of your holiday. Words, spoken or written, do not transfer meanings; they are merely stimuli that a communicator uses to arouse a response in the receiver. The nature of the response is determined by the receiver's past experience with the words and the things to which they refer³⁷. These experiences give the words their meaning – which is in the mind of the receiver, not in the words themselves.

Words cannot communicate meaning unless the listener or reader has had some experience with the concepts or objects to which the words refer³⁸. Consider the effect of your communication if your listener had never been on a holiday.

Confusion between the symbol and the thing symbolised

Words are simply representations. They represent anything that exists or that is experienced. Consider language as a map. A useful map accurately represents some specified territory; language should correspond to the objects or concepts that it represents. Like a map that contains errors, a statement that contains inaccuracies implies a relationship that does not exist.

Use of abstractions

Concrete words refer to objects that we can experience directly. Abstract words, on the other hand, stand for ideas that cannot be directly experienced, for things that do not call forth mental images in the mind of the receiver. For example, assuming a similar core of experience, if a communicator is discussing a particular fighter aircraft and refers to it as the stealth-fighter, the listeners immediately get a mental image of this aircraft (clearly the accuracy of that image will be affected by experience). The name stealth-fighter represents a concrete reality that can be seen, heard and touched. If, however, the communicator uses just the words fighter aircraft the listeners do not necessarily form a specific mental image of the stealth-fighter because there are a number of aircraft that fit that description. If the communicator uses just the word aircraft, the term is so abstract that the listeners cannot form a mental image of the stealth-fighter at all.

Abstract words do not bring forth specific items of experience in the minds of receivers. Although abstractions are convenient and useful, they can lead to misunderstandings. When abstractions are used in communication, they should be linked with specific experiences through examples and illustrations. The level of abstraction should be reduced wherever possible by using concrete and specific words³⁹. In this way the communicator narrows and gains better control of the image produced in the mind of the listener or reader.

³⁶ Reigeluth, 1983

³⁷ Sligo, 1988

³⁸ Anderson et al, 1977

³⁹ Fleming, 1987

Chapter 4—The teaching process

Effective teaching must be based on the principles of learning discussed in Chapter 1. The learning process does not seem to be naturally divisible into a definite number of steps. Sometimes it occurs almost instantaneously, as when a child learns about heat from touching a hot stove. In other cases, learning is acquired only through long, patient study and diligent practice.

A close examination of the teaching process reveals that different recognised authorities specify a varying number of steps. Here we will concern ourselves only with the four basic steps⁴⁰ that can be applied either to ground lectures or flight instruction. They are:

- Preparation
- Presentation
- Application
- Review and evaluation

Preparation

For each lesson or instructional period, you must refer to the syllabus and determine what can reasonably be covered in the time available. From this information, the objective of the lesson is set. The objective is a statement of what the student will be able to do on completion of the lesson⁴¹.

For an objective to result in the desired learning outcome it must:

- **Be achievable.** The objective must be something the student could reasonably be expected to be able to do, given their past experience.

If the student cannot achieve the objective, motivation may be adversely affected.

- **Be observable.** The objective must be observable by both student and instructor. For example, “The student will know the symptoms of the approaching stall” is not an observable objective, whereas “The student will state the symptoms of the approaching stall” is observable.

The observed performance is what evaluation should be based on.

- **Be measurable.** The objective must have some limits by which both you and student can measure acceptable performance⁴². For example, “State the symptoms of the approaching stall in the **correct order without error**”.

The parameters stated need not be perfection or final test parameters. They should relate directly to what it is you expect the student to be able to do at the end of this lesson.

In addition a statement may be made as to the conditions under which the student must perform, for example, whether by using a briefing handout or from memory.

⁴⁰ Cannon, 1992

⁴¹ Mager, 1984

⁴² Popham & Baker, 1970

In summary, in the objectives you spells out what the student is expected to do, how well, and under what conditions⁴³.

Care must be taken in preparing an objective to ensure that it accurately describes the desired learning outcome. The objective “to state the symptoms” is aimed at the knowledge level and could be achieved without the student ever having experienced a stall. Therefore, assuming the student achieved the above objective under the conditions stated, the following learning outcomes would result:

- the student can read a list from top to bottom; or
- the student has memorised a list from top to bottom.

To write a lesson objective, ask yourself these questions:

- What is it I expect the student to be able to do at the end of this lesson?
- How will I know that they are doing it?
- How well should they do it? and, if applicable,
- Under what conditions?

Preparing objectives in this way not only gives the student a clear idea of what is expected of them at the end of the lesson, but, more importantly, also focuses your attention directly on what it is you want your student to achieve as a result of your instruction.

To achieve a desired learning outcome, multiple objectives may be required. If you find you have more than three objectives for a lesson, serious consideration should be given to breaking the lesson down into smaller units.

Preparation must involve the development of a detailed written lesson plan if the instructional period is to be effective. The lesson plan is your statement of lesson objectives, the procedures and facilities to be used in presenting it, and the specific goals to be attained. The development of lesson plans by instructors signifies, in effect, that they have taught the lessons to themselves before teaching the lesson to students. The use of a lesson plan should:

- Assure a wise selection of material and eliminate unimportant details.
- Ensure due consideration is given to each part of the lesson.
- Aid the presentation of material in a suitable sequence.
- Give the inexperienced instructor confidence.

Preparation should also include pre-lesson handouts⁴⁴ or assigned reading to be completed by the student before the lesson.

As part of the preparation, you should make certain that all necessary supplies, materials and equipment are readily available and that the equipment is operating properly **before** the student arrives.

⁴³ Yelon, 1991

⁴⁴ Mayer, 1979

Presentation

It is your presentation of the knowledge and skills that make up the lesson. The choice of the method of presentation is determined by the nature of the subject matter and the objective.

The **lecture** method is suitable for presenting new material, for summarising ideas and for showing relationships between theory and practice. For example, it is suitable for the presentation of a ground school lesson on aircraft weight and balance. This method is most effective if accompanied by instructional aids and training devices. In the case of a lecture on weight and balance, a whiteboard could be used effectively, so could a seesaw.

The **demonstration-performance** method is desirable for presenting a skill, such as use of the flight navigation computer. Great care must be taken in using this method, to ensure that the demonstration follows the correct steps in the proper order, so the student gets a clear picture of each separate part of the operation.

Application

Application is the student's use of the ideas presented by you. This is where you discover if the images transmitted are similar to those received by the student, and if transfer of learning has occurred. In a classroom situation, the student may be asked to explain the new material, or to perform an operation. For example, at the end of a lesson on the use of the navigation computer, the student may be asked to work a flight-planning problem involving the computation of groundspeed and drift.

In classroom and flight instructing situations, portions of your explanation and demonstration are alternated with student practice. It is rare that you complete an explanation and demonstration and then expect the student to complete the performance.

It is very important that the student perform the manoeuvre or operation the right way the first few times, for this is when habits are established. Faulty habits are difficult to correct.

The emphasis is on the correct sequence – not the speed at which it is performed. Speed of performance may be an important goal, but it should not take precedence in the early stages of instruction.

After reasonable competence has been attained, the manoeuvre or operation should be practised until correct performance becomes almost automatic.

Review and evaluation

Review and evaluation is an integral part of each classroom or flight lesson. Before the end of the instructional period, you should review what has been covered and require students to demonstrate the extent to which the lesson objectives have been met.

Evaluation may be informal and noted only for use in planning the next lesson, or it may be recorded to certify the student's progress. In either case, the student should be aware of their progress.

In flight training you must remember that it is difficult for students to obtain a clear picture of their progress, since they have little opportunity for a direct comparison with others, especially in the early phases of training. The students recognise that they are in a competitive situation unlike any previously experienced. The unseen competitor is that intangible competency which must be achieved. The student's own evaluation can only be subjective. Direct comparisons for them are only possible with the performance of the instructor. Only you can provide a realistic evaluation of performance and progress.

In addition to knowledge and skills learned during the period just completed, each lesson should review things previously learned. If faults not associated with the present lesson are revealed, they should be pointed out. Such corrective action as is practical within the limitations of the situation should be taken immediately; more thorough remedial action must be included in future lesson plans.

The evaluation of student performance and accomplishment during a lesson should be based on the stated objective⁴⁵. For example, in the Taxiing Briefing, if you have stated the objective that the student should – watch for potholes, then you cannot evaluate the student's performance as poor when the student taxis through a pothole, especially if the student states that they saw the pothole.

Recommended Reading

Effective Aviation Instruction by R.A. Telfer (1993) in *Aviation Instruction and Training* pp.219-236. *Preparing Instructional Objectives* by R.F. Mager (1984).

⁴⁵ Gagne & Briggs, 1979

Chapter 5—Teaching methods

The instructor's skill is determined to a large degree by the ability to organise material and to select and utilise a teaching method appropriate to a particular lesson. Of the various teaching methods in common use, only the **lecture** method, the **guided discussion** and the **demonstration-performance** method will be covered here. The **pre-flight briefing** will be discussed at length in the Briefings section.

There is no definite line of division between these methods; some material requires the use of more than one method or a combination of methods⁴⁶. For example, a demonstration of how to use the aircraft radio, followed by a thorough explanation, is essentially a lecture.

The use of programmed instruction will also be discussed, as many organisations employ the principles of this type of instruction, primarily through computers when it is known as Computer-Based Training (CBT).

Organising material

Regardless of the teaching method used, you must organise the material in a logical sequence⁴⁷. One effective way to organise the lesson, and the simplest, is:

- Introduction
- Development
- Conclusion⁴⁸

Appendix A expands on this sequence.

Introduction

The introduction serves several purposes:

- To establish common ground between you and the students
- To capture and hold the attention of the student or group
- To indicate what material is to be covered and how this relates to the entire course
- To point out why the student should learn the material and what benefits the student can expect
- To establish a receptive attitude toward the lesson
- To lead into the lesson development.

The introduction should be free of stories or incidents that do not help the students focus their attention on the lesson objective. Also, a long or apologetic introduction should be avoided, as it will dampen student interest in the lesson. The introduction sets the stage for learning by gaining the student's attention, providing motivation and giving an overview of the material to be covered and its relevance to the course goals.

⁴⁶ Cannon, 1992

⁴⁷ Okey, 1991

⁴⁸ Cannon, 1992

Attention

For information to be perceived, it first must be attended to⁴⁹. Gaining and maintaining the student's attention, therefore, is of prime importance to you. One of the most effective methods is novelty⁵⁰. For example, a lesson on aircraft weight and balance might start with two students, of obviously different weights, being asked to balance out a see-saw. Or you might make an unexpected or surprising statement, eg, "for most aircraft a rearward C of G increases airspeed!" and then inviting debate by asking why. Or you might begin by telling a true story of an incident that relates to the subject and thereby establishes a background or reason for learning. No matter how you introduce the lesson, the main concern should be to gain the student's attention and focus it on the subject⁵¹.

Motivation

The introduction should offer the students specific reasons for needing to be familiar with, to know, to understand, to apply or to be able to perform whatever they are about to learn. This motivation should appeal to each student personally.

Overview

Every lesson introduction should contain an overview that tells the student or group what is to be covered during the lesson. A clear, concise presentation of the objective and the key ideas is absolutely critical, for it gives the student a road map of the route to be followed.

Development

The development of the lesson is the main part. Here you develops the subject matter in a manner that helps the students achieve the desired outcome or objective.

You must organise the material logically to show the relationships of the main points⁵². Usually these primary relationships are shown by developing the main points in one of the following ways:⁵³

- from past to present
- from simple to complex
- from known to unknown
- from most to least frequently used

From past to present

In development from past to present, the subject matter is arranged chronologically. This is most suitable when history is an important consideration, eg, when tracing the development of GPS (Global Positioning System).

From simple to complex

The simple to complex pattern helps you lead the student from simple facts or ideas to an understanding of complex concepts. In studying Lift, for example, the student might begin by considering the action of a river as it enters and leaves a narrow gorge – and finish with the Lift formula.

⁴⁹ Telfer & Biggs, 1988

⁵⁰ Fleming, 1987

⁵¹ Gibbs, Habeshaw & Habeshaw, 1988

⁵² Merrill, 1987

⁵³ Cannon, 1992

From known to unknown

By using something the student already knows you can develop concepts. For example, in discussing the properties of the magnetic compass you could revise the previously learned properties of a simple bar magnet.

From most to least frequently used

Some information or concepts are common to all who use the material. This pattern starts with the most common use before progressing to rarer ones. For example, dead-reckoning techniques for navigation are learnt before applying them to lost procedures.

Under each main point in a lesson the subordinate points should lead naturally from one to another. With this arrangement, each point leads logically into, and serves as a reminder of, the next. Meaningful transitions keep the students oriented, aware of what they have covered and what is to come⁵⁴.

Organising a lesson so that the students will grasp the logical relationships of ideas is not an easy task. The use of a lesson plan as depicted in Appendix A provides guidance on how to link ideas in a logical sequence. This type of organisation is necessary if the students are to learn. Poorly organised information is of little or no value to the student.

Conclusion

An effective conclusion retraces the important elements of the lesson and relates them to the objective. This review and wrap-up of ideas reinforces the student's learning and improves retention.

No new ideas should be introduced in the conclusion.

Lecture method

You should know how to prepare and present a lecture and should understand the advantages and limitations of this teaching method.

The lecture is used primarily to introduce students to a new subject, but it is also a valuable method for summarising ideas, showing relationships between theory and practice, and re-emphasising main points⁵⁵. The lecture method is adaptable and has several advantages. Lectures may be given to either small or large groups, they may be used to introduce a complete training program or a single unit of instruction, and they may be combined with other teaching methods to give added meaning and direction.

The success of a lecture depends on your ability to communicate effectively as well as the ability to plan, develop and review the lesson.

In other methods of teaching (demonstration-performance, guided discussion) the instructor receives direct reaction from the students in the form of verbal or motor activity. During a lecture, however, feedback is not as direct and is therefore harder to interpret. You must develop a keen perception for subtle responses from the class (facial expressions, apparent interest or disinterest) and be able to interpret the meaning of these reactions and adjust the lesson accordingly.

Planning the lecture

The competent instructor knows that careful preparation is a major factor in the successful presentation of a lecture. Preparation should start well in advance of the presentation.

⁵⁴ Cannon, 1992

⁵⁵ McLeish, 1968

Four steps should be followed in the planning phase of preparation:

- Establish the desired outcome and therefore the objective
- Research the subject
- Organise the material
- Plan interactive classroom activities

Developing the lecture

In supporting key points or ideas in the lesson, you must work on the assumption that the student may neither believe nor understand the points to be covered. In developing the lesson you should use the recommended text for the subject as well as statistics, comparisons and meaningful examples.

After completing the preliminary planning and writing the lesson plan, you should rehearse the lecture to build self-confidence. During rehearsal the mechanics of using notes, visual aids and other instructional techniques can be smoothed out. You should have your supervisor attend the practice sessions and observe the presentation critically. This critique will help you judge the adequacy of supporting materials and visual aids.

Suitable language

During the lecture, simple rather than complex words should be used whenever possible. Errors in grammar and vulgarisms detract from an instructor's dignity and reflect upon the intelligence of the students.

If the subject includes technical terms, you should clearly define each one so that no student is in doubt about its meaning⁵⁶. Whenever possible, you should use specific rather than general words. For example, the specific words "a leak in the fuel line" tell more than the general term "mechanical defect".

Another way you can enliven the lecture is to use sentences of varying length. Too many short sentences result in a choppy style; long sentences, unless carefully constructed, are difficult to follow. To ensure clarity and variety, you should use a mixture of short and medium length sentences⁵⁷.

Whatever the style adopted by you, a display of enthusiasm will greatly affect the success of any presentation. "Probably the best teachers of adults are people who are enthusiastic amateurs in their subject – at least, amateurs at teaching it"⁵⁸.

Delivery methods

You can deliver a lecture in one of four ways, by:

- reading written notes
- reciting memorised material
- speaking without notes from an outline
- speaking impromptu without preparation

⁵⁶ Hawkins, 1993

⁵⁷ Cannon, 1992

⁵⁸ Knowles, 1980, p.156

The lecture is probably best delivered by speaking without notes from an outline. You speak from a mental or written outline but does not read or memorise the material to be presented. Because the exact words with which to express an idea are left to the moment, the lecture is more personalised and provides more opportunity for enthusiasm, than one which is read or spoken from memory. Since you talk directly to the students, rather than head down reading from notes, the reactions of the students can be readily observed, and adjustments can be made to their responses. You have better control of the situation, can change the approach to deal with any situation as it arises, and can tailor each idea to suit the individual responses of the students. For example, if you realise from their puzzled expressions that a number of students fail to grasp an idea, that point can be elaborated upon until the reactions of the students indicate that they understand.

Overall, this method reflects your personal enthusiasm and is more flexible than other methods. For these reasons it is likely to hold the interest of the students.

Use of notes

An instructor who is thoroughly prepared can usually speak effectively without notes. If the lecture and outline have been carefully prepared and rehearsed there should be no real difficulty. However, if your whose preparation has been limited, you may find it necessary to use notes.

Notes do have certain advantages. They assure accuracy, jog the memory, and dispel the fear of forgetting. An instructor should not, however, be overly dependent on notes. Use them sparingly and unobtrusively, but make no effort to hide them from the students. Notes should be written legibly or typed, and they should be placed on the lectern where they can be consulted easily, or held if you walk about the platform.

Formal versus informal lectures

The lecture may be conducted in either a formal or informal manner.

Learning is best achieved if students participate actively in a friendly, relaxed atmosphere. Therefore, use of the informal lecture, which includes active student participation, is encouraged. A formal lecture, however, is still to be preferred on some occasions, such as introducing new subject matter.

You can achieve active student participation in the informal lecture through the use of questions⁵⁹. In this way, the students are encouraged to make contributions that supplement the lecture. You can use questions for one or more of the following purposes:

- to determine the experience and background of the students
- in order to tailor the lecture to their,
- to add variety and stimulate interest, or
- to check student understanding.

It remains your responsibility to plan, develop and present the lesson. The students should not be relied on for any significant portion of the lesson development.

⁵⁹ Popham & Baker, 1970

Advantages of the lecture

In a lecture, you can present many ideas in a relatively short time. Facts and ideas that have been logically organised can be concisely presented in rapid sequence. Lecturing is the most economical teaching method in terms of the time required to present a given amount of material. It is also a convenient method for large groups.

The lecture can be used to ensure that all students have the necessary basic information background to learn a new subject⁶⁰. You can offer students with varied backgrounds a common understanding of principles and facts. For example, in learning about aircraft performance, the factors affecting aircraft takeoff and landing distances could be covered in a lecture, before moving on to a demonstration-performance on the use of takeoff and landing performance charts.

If students do not have the time required for research or access to reference material, information they need can be presented in a lecture. The lecture can usefully and effectively supplement other teaching methods. A brief introductory lecture can give direction and purpose to a demonstration. For example, a lecture on the triangle of velocities could precede a demonstration of the use of the navigation computer. A lecture can also prepare students for a discussion by telling them something about the subject matter to be covered. For example, the effects of fatigue on pilot performance followed by discussion on individual experiences.

Disadvantages of the lecture

As a teaching method the lecture cannot provide for all desired learning outcomes. Motor skills can not be learned by listening to a lecture.

Too often the lecture does not provide for student participation and, as a consequence, many students willingly let you do all the work.

Learning is an active process, and the lecture tends to foster passiveness and teacher-dependence on the part of the students⁶¹.

The lecture does not enable you to estimate the student's progress before additional material is introduced. Within a single period, you may unwittingly present more information than students can absorb. The lecture method provides no accurate means of checking student learning.

Instructors find it difficult to hold the attention of all the students throughout a lecture⁶².

The successful lecture relies heavily on your skill in speaking.

Recommended reading

53 Interesting Things to do in Your Lectures by G. Gibbs et al (1991).

Planning an Instructional Sequence by W.J. Popham et al (1970)

Guided discussion method

In contrast to the lecture, where you provide information, the guided discussion relies on the students to provide ideas, experiences, opinions and information. An instructor may use this method after the students have gained some knowledge and experience, during classroom

⁶⁰ Hawkins, 1993

⁶¹ Hawkins, 1993

⁶² Brown & Atkins, 1991

periods or pre-flight and post-flight briefings. This method is particularly applicable to CPL and your own instructor training.

Fundamentally, the guided discussion is the reverse of the lecture method. You should aim to draw out what the students know, rather than telling them. You must remember that the more intense the discussion and the greater the participation, the more effective the learning will be. You must be sure that all members of the group follow the discussion, and that all are treated impartially. You must encourage questions, exercise patience and tact, redirect questions to other members of the group where possible, and comment on all responses.

Use of questions

In the guided discussion, learning is produced through the skilful use of questions⁶³. The instructor often uses a question to open up an area for discussion, which may be directed at the entire group to stimulate thought or a response from each group member. Its purpose is to get discussion started. For example, “What can you tell me about Lift?”

The rhetorical question is similar in nature because it also spurs group thought. For example, “What is Lift?” you answer the rhetorical question, however, and it is more commonly used in the lecture. After the discussion develops, you may ask a follow-up question to guide the discussion. For example, “What is the relationship between true airspeed and Lift?” The reasons for using a follow-up question may vary. You may want a student to explain something more thoroughly, or may need to bring the discussion back to a point from which it has strayed. If, however, a response is desired from a specific individual, perhaps to encourage participation, a direct question may be asked of that student. Be certain to acknowledge the response.

Rather than give a direct answer to a student’s question, you may elicit the answer by redirecting the original question (or a modified version of it) back to the individual, to another student, or to the entire group.

Questions used to evaluate or measure student learning should require a specific answer relating to the material covered. For example, “If true airspeed is doubled, and everything else remains constant, by how much will the Lift increase?” The question, “Any questions?” should rarely, if ever, be used.

Questions should:

- Have a specific purpose
- Have a clear meaning
- Contain a single idea
- Stimulate thought
- Require definite answers
- Relate to previously taught information

Planning a guided discussion

Planning a guided discussion is similar to planning a lecture. In addition the following suggestions⁶⁴ may help:

⁶³ Hall, 1983

⁶⁴ Popham & Baker 1970

Select a topic the students can profitably discuss

Unless the students have some knowledge to exchange with each other, they cannot reach the desired learning outcomes by the discussion method. If necessary, set assignments that will give the students an adequate background for discussing the lesson topic. For example, “Research factors which may influence the successful outcome of an engine failure after takeoff”.

Establish a lesson objective and desired learning outcomes

Through discussion, the students develop an understanding of the subject by sharing knowledge, experiences and backgrounds. Consequently, the objective is normally stated at the understanding level of learning. For example, “To explain the factors which may influence the successful outcome of an engine failure after takeoff”. The learning outcomes should stem from and be related to the objective. For example, “Recognise the value of a pre-takeoff emergency brief, develop situational awareness and be aware of aircraft performance limitations”.

Conduct adequate research to become familiar with the topic

While researching, you should always be alert for ideas on the best way to tailor a lesson for a particular group of students. For example, a lecture or discussion on the use of the aircraft radio could profitably be combined with a visit to the control tower. During the research process, you should collect (or set an assignment for the students to collect) appropriate background-reading material. Such material should be well organised and based on the fundamentals.

Organise the main points of the lesson in a logical sequence

The guided discussion has three main parts – introduction, discussion and conclusion. The introduction consists of gaining attention, motivation and overview. During the discussion, you should ensure that the main points build logically to the objective, minimising the possibility of a rambling presentation. The conclusion consists of the summary and re-motivation.

Plan at least one question for each desired learning outcome

In preparing questions, you should remember that the purpose is to bring about discussion, not merely to get answers. Questions that require only short answers such as “yes” or “four” should be avoided⁶⁵. Questions framed to encourage discussion usually start with “how” or “why”. For example, “Why does altitude affect takeoff performance?” rather than “Does altitude affect takeoff performance?” The first question invites discussion, the second, an answer of “yes”.

Student preparation

“Involving the student so that learning becomes co-operative produces superior results to those achieved by competitive or individual approaches”⁶⁶. It is your responsibility to encourage students to accept responsibility for their learning, by contributing to and profiting from, the discussion. Students should be made aware of the lesson objective and be given pre-lesson research or study to complete.

If you have no opportunity to assign preliminary work, it is advisable to give the students a brief general overview of the topic during the introduction. Under no circumstances should students without some background in a subject be asked to discuss that subject.

⁶⁵ Cannon, 1992

⁶⁶ Telfer, 1993, p.221

Guiding a discussion

Introduction

A guided discussion is introduced in the same manner as a lecture. The introduction should include an attention step, a motivation step and an overview of key points. To encourage enthusiasm and stimulate discussion, you should show enthusiasm, “it’s infectious”⁶⁷, and create a relaxed, informal atmosphere. Each student should be given the opportunity and encouragement to discuss aspects of the subject. You must make the student feel a personal responsibility to contribute, and that their ideas and active participation are wanted and needed. “The instructor’s job is not as simple as ensuring that the syllabus is presented to the student”⁶⁸.

Discussion

You open the discussion by asking one of the prepared questions. After asking a question you should give the students a chance to react⁶⁹. You have the answer in mind before asking the question, but the student has to think about the question before answering. You must be patient while the students figure out the answer. It takes time to recall data, word an answer or think of an example. The more difficult the question, the more time the student will need to produce an answer.

Sometimes students may not understand the question. Whenever you detect this, the question should be restated in a slightly different form.

Once the discussion is under way, you should listen attentively to the ideas, experiences and examples contributed by the students during the discussion. During preparation, you will have anticipated the responses that indicate the students have a firm grasp of the subject. As the discussion proceeds, you may find it necessary to stimulate the students to explore the subject in greater depth or guide the direction of the discussion and encourage them to discuss the topic in more detail. By using how and why follow-up questions, you should be able to guide the discussion toward the objective of understanding the subject.

Once the students have discussed the ideas that support the objective, you should summarise what the students have accomplished.

In a discussion lesson, an interim summary is one of the most effective tools available to you to bring ideas together. In addition the interim summary may be used to keep the group on the subject or divert the discussion to another member.

Throughout the discussion it is desirable to record ideas, facts and agreements so that the group can see relationships and the progress that has been made. The whiteboard or blackboard is suitable for this purpose. Brainstorming is a special version of this process, where all ideas on a subject – no matter how weird – are recorded without criticism and then discussed by the group. This method is useful for creating an informal, relaxed atmosphere.

Conclusion

A guided discussion is closed by summarising the material covered. In the conclusion, you should tie together the various points or topics discussed and show the relationships between the facts brought forth and the practical application of these facts⁷⁰. As an example, in concluding a discussion on engine failure after takeoff, an instructor might give statistical results of the attempted turn back as against other options.

⁶⁷ Telfer, 1993, p.224

⁶⁸ Telfer, 1993, p.231

⁶⁹ Cannon, 1992

⁷⁰ Cannon, 1992

The summary should be brief but not to the point of incompleteness. If the discussion revealed that certain areas are not understood by one or more members of the group, you should clarify this material.

Demonstration-performance method

The demonstration-performance method is used extensively in flight instruction during the air exercise and is based on the principle that we learn by doing. Students learn physical or mental skills by performing those skills under supervision. An individual learns to write by writing, to weld by welding, and to fly an aircraft by performing flight manoeuvres.

Great care must be taken in using this method, to ensure that the demonstration follows the correct steps, in the proper order, so that the student gets a clear picture of each part of the operation. The demonstration-performance method has five essential phases:

- Explanation
- Demonstration
- Instructor supervision
- Student performance
- Evaluation

Explanation

“If telling was the same as teaching we would all be so smart we could hardly stand it”⁷¹.

In flight training, the explanation phase is served by the pre-flight briefing. Explanations must be clear, pertinent to the objectives of the lesson, and based on the known experience and knowledge of the students.

You must convey to the student the precise actions they are to perform, the expected result of those actions, and the possible effects of those actions on the student.

Before leaving this phase, you should ask questions so as to determine if there is understanding of the procedure to be followed.

Demonstration

Before the demonstration, you direct the attention of the student to no more than two items to be closely observed during the demonstration. These are the one or two items you considers vital for the execution of the skill. For example, in the steep turn, “note the aircraft nose attitude and bank angle in relation to the horizon.” Then you must show the student the actions necessary to perform the skill. As little unrelated activity as possible should be included in the demonstration if the student is to clearly understand that you are accurately performing the actions previously explained. Therefore, there is no verbal patter during this phase. The demonstration serves as a physical restatement of the objective, “here is what you will be able to do at the end of this lesson.”

If, because of unanticipated circumstances, the demonstration does not closely conform to the explanation, the discrepancy should be immediately acknowledged and explained.

⁷¹ Mager, 1968, p.7

Instructor supervision, student performance

Instructor supervision and student performance involve separate actions, but they are performed concurrently, so they are discussed here under a single heading.

During the first phase of instructor supervision, you guide the student through the various components required to perform the skill through the use of pattern and follow-me-through. Immediately thereafter you should give the student an opportunity to perform the skill, coaching as necessary.

The second phase of student performance requires the student to practice in order to learn the skills. Therefore, adequate time must be allocated for this student activity. During this phase, feedback should be gradually reduced and finally eliminated⁷².

Where the demonstration-performance method is used in group instruction (weight-and-balance computations, or use of the navigation computer, for example), before terminating the performance phase, opportunity should be given for the operation to be completed at least once independently, with supervision on an as-needed basis.

Evaluation

In this phase you judge student performance. The student displays whatever competence has been attained, and you discover how well the skill has been learned. From this measurement you determine the effectiveness of his or her instruction.

To measure each student's ability to perform, you require the students to work independently. Therefore, throughout this phase, you must not ride the controls nor offer verbal or body language cues. Any comment as to how well any individual performed the skill must be in relation to the stated objective for the lesson, not necessarily on perfection of the skill or flight test parameters.

Programmed instruction

Programmed instruction is a method of developing self-instructional materials in textbook form or for computers⁷³.

As student's progress through programmed instructional material, they make a response to each increment of instruction. The material offers them immediate feedback by informing them of the correctness of their responses. The successful completion of each of these increments takes the student one step closer to the intended learning outcome.

The major characteristics of programmed instruction are:

- A clear statement of what the student will be able to do after training
- Careful sequencing of material
- Presentation of material in steps which challenge students but do not exceed their ability
- Active student responses
- Immediate confirmation of answers
- Test and revision of material until the desired learning outcome is achieved

⁷² Anderson & Faust, 1973

⁷³ Hawkins, 1993

This approach carries students, step by step, to the learning objectives. In this respect, programmed instruction is generally more tutorial than typical classroom instruction. It gives the student not only what they are to learn, but also guides them in how they are to learn.

Types of programmed instruction

Programmed instruction may be branched or linear.

Branched

Typically, branched instruction gives more information than linear and then requires an answer to be chosen from the multiple-choice type. Each answer has a reference page to turn to. If the correct answer is chosen, new material will be presented. If an incorrect answer is chosen, remedial material will explain where the student went wrong.

For an example of this type of instruction, read *Preparing Instructional Objectives* by R.F. Mager. This type of programmed instruction is well suited to use with computers⁷⁴.

Linear

In linear programmed instruction, the material is itemised and presented in very small steps. A student is prompted so that invariably the correct response is given. Materials are carefully designed to offer as much review as needed to assure the degree of retention appropriate to the subject matter, the learning situation and the needs of the student⁷⁵.

The student responds by writing words into spaces provided for that purpose. Linear programming may also be designed to elicit other types of responses. Answers may be given mentally or orally and simple tasks may be performed. Sequences of more complicated tasks that make up a complete procedure may be required.

After completing the response, the student immediately confirms the correctness of the response by comparing it to the program answer before continuing. Thus, the student progresses smoothly, with a continuous awareness of being correct giving a sense of satisfaction. If the programme is properly constructed, the student will, at a comfortable rate and almost effortlessly, learn the material presented⁷⁶.

Proponents of this system⁷⁷ attribute its success to the reinforcement it provides and the repetition it uses. If a student encounters the same fact, idea or concept in a number of ways, and if reinforcement or reward occurs each time a correct answer is made, learning takes place.

Each block of new subject matter contains obvious cues to the correct response. Thus, a student finds it virtually impossible to make errors. As a student approaches the learning objective, cues are gradually withdrawn until the student supplies complete answers without being cued.

For an example of linear type programmed instruction, see the Climbing Briefing – the presentation of the forces acting on the aircraft in a climb. To the casual observer, this sequence may seem unduly simple. To the student who is totally unfamiliar with the subject matter, however, it offers a sort of learning game.

⁷⁴ Gagne, Wager & Rojas, 1991

⁷⁵ George, 1970

⁷⁶ Skinner, 1968

⁷⁷ Skinner, 1958, Lumsdaine & Glaser, 1960

Chapter 6—Evaluation

Evaluation is an integral part of the learning process. Whenever learning takes place, the result is a change in behaviour. Evaluation is concerned with defining, observing and measuring the new behaviour. Once instruction has begun, some sort of evaluation is essential to determine both **what** and **how well** the student is learning, as well as how effective the course of instruction has been⁷⁸. Evaluation for these purposes may be **formative**, ie, it is used during a course of instruction, or **summative**, when it is used at the completion of a course of instruction⁷⁹.

Your evaluation may consist simply of observations of the student's performance, or it may be accomplished by more **comprehensive, systematic** and **objective** means, by oral questioning, administering written tests, or performance testing⁸⁰.

Observations

Flight instructors have a moral obligation to provide guidance and restraint with respect to the operations of their students. This applies to instructor's observations of unsafe or inept operations by pilots who are not aware they are being observed, as well as pilots who have requested an instructor's evaluation or guidance. In the case of an observed unsatisfactory performance, it is your responsibility to try to correct it by the most reasonable and effective means. If unable to correct the situation by personal contact and good advice, you should report the matter to their supervisor.

Recording Observations

Subjective written records of observed student performances are known as **anecdotal records**. Generally, a filing card system is used to record student behaviour that cannot be evaluated by other means, for example, respect for laws, reaction to authority, persistence or physical skill. The main advantage of these records is that they depict behaviour in natural situations. For example, a student may show good knowledge of VFR minima but violate them in everyday situations. These records often form the basis of a written debrief, and they can be of considerable help to the instructor who is to fly with a previously unknown student.

You should record sufficient information about the situations to make the behaviour understood, for example, "entered cloud while concentrating on instruments in the turn". Just enough detail should be included to make the description meaningful and accurate. The description should be as objective as possible and it should record positive as well as negative incidents.

A more structured form of anecdotal record is the **rating scale**. Rating scales provide a systematic procedure for reporting your observations. Its value depends on careful preparation and appropriate use. For example, it should measure the desired learning outcome, and it should be used when sufficient opportunity exists to make the necessary observations.

A rating scale, as developed by Massey University and being expanded by CAA, in the measurement of Managing Critical Incidents is given below as an example.

⁷⁸ Baker & O'Neil, 1987

⁷⁹ Tuckman, 1985

⁸⁰ Gronlund & Linn, 1990

Aircraft Performance and Operating Requirements

Rating Scale

0	5	10
FAIL	PASS	
<ol style="list-style-type: none">1. Uses inappropriate performance charts, tables of data.2. Uses inappropriate conditions for the calculation of takeoff or landing distance, such that safety would be compromised.3. Fails to ensure sufficient runway length is available for takeoff or landing.	<ol style="list-style-type: none">1. Uses appropriate performance charts, tables and data.2. Uses the appropriate conditions to calculate the takeoff and landing distance for private operations.3. Ensures sufficient runway length is available for takeoff and landing through local knowledge.	<ol style="list-style-type: none">1. Uses all appropriate performance charts, tables and data.2. Uses the appropriate conditions to calculate accurately and quickly the takeoff and landing distance for private operations.3. Ensures sufficient runway length is available for takeoff and landing by correctly comparing distance required to distance available.

Oral Questioning

Oral questioning has a wide range of uses in flight instruction. Questions that require the recall from memory of a fact usually start with who, what, when or where. Questions that require the student to combine knowledge of facts with the ability to analyse a situation, solve problems or arrive at conclusions usually start with why or how.

Your use of oral questioning can have a number of desirable results:

- It reveals the effectiveness of your instruction.
- It checks the student's retention of what has been learned.
- It reviews material already covered by the student.
- It can be used to retain the student's interest and stimulate thinking.
- It can be used to emphasise important points.
- It checks student comprehension.
- It may identify points that need more emphasis.
- It promotes active student participation, which is essential to learning.

Characteristics of Effective Questions

Preparation

Effective oral questioning requires preparation. You, therefore, should write pertinent questions in advance. The recommended method is to place them in the lesson plan. These prepared questions serve as a framework and, as the lesson progresses, should be supplemented by any impromptu questions you consider appropriate. To be effective, these questions must be adapted to the past experience and present ability level of the student.

One idea

Effective questions centre on only one idea. One idea – one question. A single question should be limited to using who, what, when, where, how or why – not a combination.

Brief

An effective question should be brief and concise. Enough concrete words must be used to establish the conditions or situation exactly, so that instructor and student have similar mental pictures. The student's response should be determined by their knowledge of the subject – not by their ability to understand the question.

Relevant

To be effective, questions must apply to the subject of instruction⁸¹. Unless the question pertains strictly to the particular training being conducted, it serves only to confuse the student and divert their thoughts to an unrelated subject. Any part of a question that the student could disregard and still respond correctly should probably be removed.

Only One Answer

Usually an effective question has only one correct answer, although in a problem solving question it may be expressed in a variety of ways.

Challenging

Effective questions present a challenge to the student. Questions of suitable difficulty serve to stimulate learning. The difficulty of the question should be appropriate to the student's level of training.

Questions to Avoid

Asking “Do you understand?” or “Have you any questions?” have no place in effective questioning. Assurance by the student that they do understand, or that they have no questions, provides no evidence of their comprehension.

Catch-em-out questions should be avoided, as the student will soon develop the feeling that they are engaged in a battle of wits with you. Other types of questions to avoid are:

The puzzle

“What is the first action you should take if a conventional gear aircraft with a weak right brake is swerving left in a right crosswind during a full-flap power-on wheel-landing?”

The oversize

“What do you do before starting the engine?”

The toss-up

“In an emergency, should the crew activate the escape slide or control the passengers?”

⁸¹ Cronbach, 1980

Bewilderment

“In reading the altimeter – you know you set a sensitive altimeter for the nearest station pressure – if you take temperature into account, as when flying from a cold air mass through a warm front, what precaution should you take when in a mountainous area?”

Irrelevant

The teaching process is an orderly procedure of building one block of learning upon another, and the introduction of unrelated facts and thoughts will only obscure this process and retard the student’s progress.

Answering a Student’s Questions

The answering of a student’s questions must conform to certain considerations if it is to be an effective teaching method.

The question must be clearly understood by you before an answer is attempted. You should display interest in the student’s question and frame an answer as direct and accurate as possible. For example, if the student asks “What is drag?” an appropriate answer would be, “Drag is the resistance experienced by a body in motion through a fluid”.

After you complete a response, it should be determined whether or not the student is completely satisfied with the answer. In the example given, this may lead to a discussion on the factors that affect drag. Organising the answers in this way conforms with the recommended teaching method for the development of a subject, in this case from simple to complex.

Sometimes it may be unwise to introduce the more complicated or advanced considerations necessary to completely answer a student’s question, for example, the drag formula. In this case, you should carefully explain to the student that the question was good and pertinent but that the answer would, at this time, unnecessarily complicate the learning task at hand. This is particularly true of the pre-flight brief where time does not permit irrelevant or in-depth discussions. If it will not be answered later in the normal course of instruction, you should advise the student to ask it again later.

On rare occasions, a student asks a question which you cannot answer; you should freely admit not knowing the answer, but should get the answer. If practicable, you could help the student look it up in available references.

Instructors should avoid using the one-word answers “Yes” or “No” if the greatest instructional benefit is to be gained from the student’s question.

Written Tests

As evaluation devices, written tests are only as good as the knowledge and proficiency of the test writer. The following are some of the basic concepts of written test design.

Many publications are available on test administration, test scoring and test analysis, so these topics are not covered in this chapter⁸².

Characteristics of a Good Written Test

If a test is to be effective, it must have certain characteristics; the most important of these are **validity**, **reliability** and **useability**⁸³.

⁸² refer to ‘Gronlund & Linn, 1990, p.240

⁸³ Gronlund & Linn, 1990

Validity

Validity is the most important feature of any written test; it is the ability of a test to measure what it is supposed to measure. The results of a written test are said to be valid only when they are interpreted in relation to what the test was supposed to measure. For example, if instruction has centred on the term stalling angle, and the test question refers to the critical angle, the test result would be invalid in relation to the stalling angle, but it may have validity if interpreted in relation to a broader knowledge of stalling.

Reliability

Reliability refers to the consistency of results obtained from a test or any other measuring device. A metal rule that expands and contracts with temperature changes will not give reliable results. By the same token using a device that is highly reliable does not necessarily mean the results will be valid. For example, an altimeter incorrectly calibrated will consistently measure altitude above the wrong datum; the result is reliable, but wrong (not valid).

Useability

Useability is a measure of the test's practicality irrespective of other qualities. Tests should be easily administered and scored, produce results that can be accurately interpreted, and be economical in time and cost.

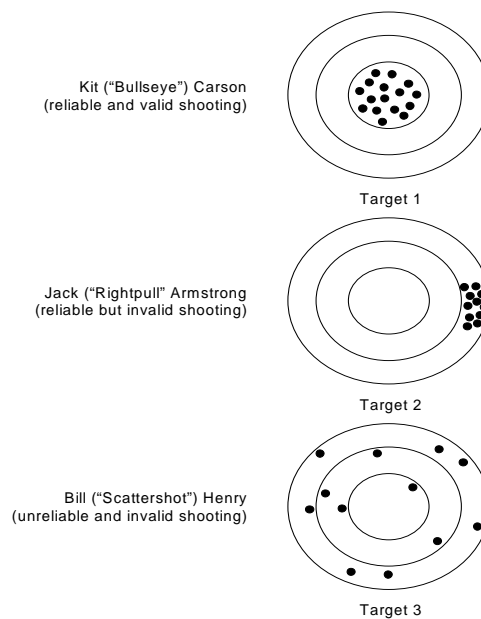

Source: Gronlund & Linn, 1990, p.49.

Written Test Questions

In flight instruction the essay-type question is rarely used and will not be discussed here. Those most commonly used are:

- The short-answer type, which for the purposes of this discussion includes the true/false type.
- The multiple-choice type, which for the purposes of this discussion includes the matching type.

Short-Answer Type

The short-answer question requires the student to supply their own answer. The shortest possible answer will be in response to the true/false question, and the longest answer extending to perhaps half a page! Other than the true/false type, these questions can be difficult to mark; for example, in the simplest one-word answer type, “The aircraft stalls at the _____ angle” the answer could be stalling, critical or same, and you are sure to get someone who answers with 15-degree. The correctness of the answer is subjective (decreasing reliability as well as validity depending on how the answer is interpreted). Therefore, the same test graded by different instructors may result in different scores. The more latitude the student has in the answer the more difficult it becomes to assess their answer. While the true/false question eliminates this problem, it also provides the highest probability of guessing the answer. For these reasons the multiple-choice or matching type question is generally favoured.

Multiple-Choice Type

When properly devised and constructed, the multiple-choice type offers several unique advantages that make it more widely used and versatile than either the matching or true/false question.

Multiple-choice questions are highly objective; that is, the results of such a test would be graded the same regardless of the student taking the test or the person marking it (reliability). This makes it possible to directly compare the performance of students within the same class or in different classes, students under one instructor with those under another, and student accomplishment at one stage of instruction with that at later stages (validity). This type of test question permits easy marking and allows you to examine more areas of knowledge, over the same period, than could be done by requiring the student to supply written responses (useability).

Three major difficulties are encountered in the construction of multiple-choice test questions:

- development of a question stem which can be expressed clearly and without ambiguity;
- an answer which cannot be refuted; and
- the invention of distracters which will be attractive to those students who do not possess the knowledge or understanding necessary to recognise the correct answer.

The stem

The stem may take several forms:

- it may be a direct question followed by several possible answers;
- it may be an incomplete sentence followed by several possible completions to the sentence; or
- it may refer to a graph or diagram followed by several correct or incorrect statements about the graph or diagram.

The student may be asked to select the one choice that is the **correct** answer, the one choice that is the **incorrect** answer, or the one choice that is the **most correct** answer.

These three methods of answering, combined with the three question forms, give you flexibility in preparing multiple-choice questions. However, experience has shown that the direct question form is the most successful for instructors inexperienced in the writing of multiple-choice questions.

Examples:

Stem presented as a direct question

This form is generally better than the incomplete stem in that it is simpler and more natural.

Which gas forms the largest part of the atmosphere?

- a) oxygen
- b) nitrogen
- c) helium
- d) hydrogen
- e) neon

Stem as an incomplete statement

When using this form, care must be taken to avoid ambiguity, giving clues and using unnecessarily complex or unrelated alternatives.

The atmosphere is a mixture of gases, the largest part being:

- a) oxygen
- b) nitrogen
- c) helium
- d) hydrogen
- e) neon

Stem supplemented by a diagram

Useful for measuring ability to read instruments or identify objects.

Name and label the four forces acting on the aircraft in straight-and-level flight.

“None of the above” or “all of the above” as alternatives

These are very poor alternatives and should not be used. This is why no example is given here.

The negative variety

These should be avoided as the negative raises the difficulty of the question. If they must be used, the negative should be emphasised.

Which of the following is **NOT** used to control an aeroplane in flight?

- a) elevator
- b) aileron
- c) throttle
- d) cyclic
- e) rudder

Association type

This type is useful if a limited number of associations are to be made. Matching questions serve better if a large number of related associations are to be made.

Which manoeuvre does **NOT** belong with the others?

- a) chandelle
- b) autorotation
- c) lazy eight
- d) loop
- e) steep turn

Definition type

These are useful for determining knowledge of basic rules or facts.

The difference between Magnetic North and True North is known as

- a) turning error
- b) variation
- c) deviation
- d) compass error
- e) dip

When multiple-choice questions are used, four or five alternatives are generally provided. It is usually difficult to construct more than five plausible responses. If there are less than four alternatives, the probability of guessing the correct response is considerably increased.

Principles of Multiple-Choice Type Question Construction

Make each question independent of every other question in the test. The wording of a question in the test should not provide the correct answer to any other question. For example, avoid pairs of questions like this: Q1. If an aircraft has a rate of climb of 500 feet per minute, what amount of altitude will be gained in one minute? Q2. Define Rate of Climb. Another bad practice is to have the answer to any question dependent on knowing the correct answer to any other question. For example, this is bad: Q1. If an aircraft weighs 1600 lb, how much lift will be required for straight-and-level flight? Q2. If the Lift/Drag ratio is 10:1 how much drag is produced in Q1?

Design questions that call for essential knowledge rather than abstract background knowledge or unimportant facts.

State the question in the working language of the student. A common criticism of written tests is the emphasis on the reading ability of the student. If language comprehension is not the objective of the test, failing to use appropriate language will decrease validity.

Include sketches, diagrams or pictures when they can present a situation more vividly than words. They add interest and avoid reading difficulties with technical language.

Avoid the negative word or phrase. A student who is pressed for time may identify the wrong response simply because the negative form was overlooked.

Double negatives should be avoided because invariably they cause confusion. If a word such as “not” or “false” appears in the stem, avoid using another negative in the alternatives.

Catch questions, unimportant details and leading questions should be avoided as they do not contribute to effective evaluation. Moreover, they tend to antagonise the student.

Principles of Stem Construction

The stem should clearly present the problem or idea. The function of the stem is to set the stage for the alternatives that follow.

The stem should be worded in such a way that it does not give away the correct response.

Put everything that pertains to all alternatives in the stem. This helps to avoid repetitious alternatives.

Generally avoid using “a” or “an” at the end of the stem. These may give away the correct choice. Every alternative should fit grammatically with the stem.

Principles of Alternatives Construction

Incorrectness should not be the only criterion for the distracting alternatives. A common misconception or a statement that is itself true but does not satisfy the requirements of the problem, may also be used.

Keep all alternatives of approximately equal length.

When alternatives consist of numbers they should be listed in ascending order

Matching Type

The matching type question is particularly good for measuring the student’s ability to recognise relationships. As this question type is a collection of multiple-choice questions it samples more student abilities in a given period of time. Samples of two different forms of this type follow.

Equal Columns: When using this form, always provide for some questions in the response column to be used more than once or not at all to preclude guessing by elimination; for example,

- | | |
|--|-------------|
| a) Never exceed speed | 1) V_a |
| b) Best angle of climb speed | 2) V_{no} |
| c) Red radial line on the airspeed indicator | 3) V_x |
| d) Design manoeuvring speed | 4) V_{ne} |
| e) Best rate of climb speed | 5) V_y |

Unequal Columns: Generally these are preferable to equal columns.

- | | |
|--|-------------|
| a) Never exceed speed | 1) V_a |
| b) Best angle of climb speed | 2) V_{no} |
| c) Red radial line on the airspeed indicator | 3) V_x |
| d) Design manoeuvring speed | 4) V_{fe} |
| e) Best rate of climb speed | 5) V_{ne} |
| | 6) V_y |

Principles of Matching-Type Question Construction

Unlike the examples above, give specific and complete instructions. Do not make the student guess what is required.

Also unlike the questions above, test only essential information.

Use closely related material throughout the question.

Where possible, make all responses plausible.

Use the working language of the student.

Arrange the alternatives in a sensible, easily read order.

If alternatives are not to be used more than once, provide extra alternatives to avoid guessing by elimination.

Effective Question Writing

Question writing is one of your most difficult tasks. Besides requiring considerable time and effort, the task demands a mastery of the subject, an ability to write clearly, and an ability to visualise realistic situations for developing relevant questions. Because of the time and effort required in the writing of effective questions, it is desirable to establish a question bank or pool. As long as precautions are taken to safeguard the questions in a pool, the burden of continually preparing new questions will be lightened (but not eliminated). The most convenient and secure method is to record questions on your own home computer or floppy disk. These can be added to or amended as required, and using the cut and paste feature, different examination papers can quickly be compiled and printed.

Principles of Effective Question Writing

Regardless of the question type or form, the following principles should be followed in writing or reviewing questions⁸⁴.

Each question should test a concept or idea that it is important for the student to know, understand or be able to apply.

The question must be stated so that everyone who is competent in the subject would agree on the correct response.

The question should be stated in the student's working language.

The wording should be simple, direct and free of ambiguity.

Sketches, diagrams or pictures should be included if they add realism or aid the student in visualising the problem.

The question should present a problem that demands knowledge of the subject. A question that can be responded to on the basis of general knowledge does not test achievement.

Performance Tests

If a student demonstrates the ability to perform selected parts of a skill for which they are being trained, it is assumed that they will be able to perform the entire skill. Performance testing is a sampling process. It should be a carefully selected part of an action process

⁸⁴Tuckman, 1988

typical of the skill for which training is being given. For example, successful completion of a cross-country flight test would assume the student is able to fly anywhere in New Zealand.

This method of evaluation is particularly suited to the measurement of student abilities in action either mental or physical tasks. Performance testing is desirable for evaluating training that involves an operation, a procedure or a process, and it is used extensively in flight instruction.

Evaluation of demonstrated ability during flight instruction must be based upon established standards of performance (see Advisory Circular AC61-1), suitably modified to apply to the student's experience, stage of development as a pilot and the conditions under which the demonstration was performed. For the evaluation to be meaningful to you, the student's mastery of the elements involved in the manoeuvre must be considered, rather than merely the overall performance.

In evaluating student demonstrations of piloting ability, as in questioning and other instructional processes, it is important to keep the student informed of progress. This may be done as each procedure or manoeuvre is completed or during the debriefing.

Chapter 7—Instructional aids

An instructional aid is any device that assists an instructor in the student's learning process. They may be sight or sound devices, or a combination of both. Instructors use them to improve communication between themselves and their students, but the aids do not substitute for instruction⁸⁵; they are used to support, supplement or reinforce teaching.

Reasons for using them

Gaining and holding student attention is essential to learning. Visual aids which support the topic with some degree of novelty, draw attention to the information and cause both the seeing and hearing channels of the mind to process the same or similar information⁸⁶.

An important goal of all instruction is for the student to retain as much of the instruction as possible and a significant improvement in student retention occurs when instruction is supported with meaningful aids⁸⁷.

It is difficult for instructors to use words that have the same meaning for the student as they do for you. For example, try describing level attitude, using words only, to a student that has not flown before. The good instructor makes learning easier and more accurate for the student by providing visual images⁸⁸.

It is often difficult for a student to understand relationships, for example, C_L to Angle of Attack. If the relationships are presented visually, they are much easier to deal with. Symbols, graphs and diagrams can show relationships of location, size, time, frequency or value⁸⁹.

Instructors are frequently asked to teach more and more in less and less time. Instructional aids can help them do this.

Guidelines for their use

The decision to use any instructional aid should be based on its ability to support a specific point in a lesson⁹⁰.

Aids should be simple and compatible with the learning outcomes to be achieved. Since aids are used in conjunction with a verbal presentation, words on the aid should be kept to a minimum and distracting artwork avoided⁹¹. You should avoid the temptation of using the aid as a crutch. For example, in recent years the introduction of the overhead projector (OHP) saw many instructors fall into this trap, believing that an overhead transparency, with everything on it, could substitute for the lesson or briefing. A six-by-six rule of thumb can be applied to the preparation of overhead projector transparencies – 6 words across and 6 lines down, **maximum**.

Aids have no value in the learning process if they cannot be heard or seen. Recordings of sounds and speeches should be tested for adequate volume and quality. Visual aids must be visible to the entire class, with lettering large enough to be seen by the students farthest from

⁸⁵ Voegel, 1986

⁸⁶ Berlyne, 1970

⁸⁷ Levie & Lentz, 1982

⁸⁸ Salomon, 1984

⁸⁹ DeCecco & Crawford, 1974

⁹⁰ Briggs & Wager, 1981

⁹¹ Bovy, 1981

the aid. Colours, when used, should contrast and be easily visible. The surest and most successful rule is, before the student arrives, test visual and aural aids in the environment in which they will be used.

The effectiveness of aids can be improved by proper sequencing⁹². Sequencing can be made relatively simple by using acetate overlays on transparencies or imaginative use of magnetic boards. Sequencing can be emphasised and made clearer by the use of contrasting colours.

The effectiveness of aids and the ease of preparation can be increased by planning them in rough draft form. The rough draft should be carefully checked for accuracy, clarity and simplicity. Revisions and alterations to a draft are easier to make than changes to a final product.

The purpose of all instructional aids is to improve the student's understanding so care must be taken to present information from the student's perspective. For example, when using an attitude window, point out what the attitude looks like from the student's (left-seat) perspective.

Types

Some of the most common aids are whiteboards, models, illustrations, handouts, projected materials and computers.

Whiteboard or blackboard

The whiteboard is one of the most widely used aids to learning. Its versatility and effectiveness make it a valuable aid to most types of instruction. The following practices are fundamental in the use of a whiteboard or blackboard.

- Keep the board clean.
- Erase all irrelevant material.
- Keep chalk or pens, erasers, rulers and other equipment readily available to avoid interruption of the presentation.
- Organise the board and practice the presentation in advance.
- Write or draw large enough for everyone in the group to see.
- Do not overcrowd. Leave a margin around the material and space between lines.
- Present material simply and briefly.
- If necessary, use the ruler or other devices in making drawings.
- Use colour for emphasis.
- Stand to the side of the material being presented, so that the entire class will have an unobstructed view.
- Do not talk to the board – when speaking, face the student or group; when writing, write!

⁹² Eysenck, 1984

Models

A model is a realistic copy or simulation of a real piece of equipment. Models are not necessarily the same size as the equipment they represent, or are they necessarily workable. However, a model is generally more effective if it works like the original. With the display of an operating model, the students can observe how each part works in relation to the other parts, ailerons for example. As instructional aids, models are usually more practical than originals because they are lightweight and easily moved.

The most commonly used model in flight instruction is that of an aircraft. In accordance with the above general principles the model aircraft should at least bear some resemblance to the aircraft being used for training, high- or low-wing for example.

You should always hold the model aircraft by the nose, so that the tail of the aircraft points toward the student. This gives the student the perspective of sitting in the pilot's seat. For example, which aileron goes down and which goes up in the turn is your problem to solve not the student's.

Illustrations

Material should be displayed in a clear, easily understood format. Safety posters are a good example. A large photograph of the aircraft instrument panel is particularly useful. However, as with any other model representation, it is of little value – even detrimental – if it does not represent the aircraft in use. An extreme example would be using a photograph of the Concorde instrument layout for a pilot training in a Cessna.

Handouts

Handouts comprise any written material distributed in relation to the lesson. They can include copies of your notes, illustrations, articles or overhead projection material. They may be distributed during, or at the completion of the lesson, depending on your preference.

For the pre-flight briefing, handouts are best utilised in a systematic manner, linking the exercises being taught.

For example, at the completion of the straight-and-level lesson the student is given a handout on climbing. This first asks relevant questions in regard to the practical aspects of straight-and-level. Revision questions relating to earlier instruction could also be included. Then the handout covers the theory and considerations of climbing in depth. This is in more detail than would be covered in the pre-flight brief including, for example, any relevant checklists or radio procedures. The handout ends with relevant questions on the climbing text.

You now presents the pre-flight briefing on climbing, and the exercise is flown and de-briefed. Then a handout on descending is given to the student, on the first page of which are questions relating to climbing air exercise – and the cycle is repeated.

The use of handouts in this manner provides a continuous cycle of repetition, recency and arousal.

Projected material

Projected material includes motion pictures, video, slides, and overhead projection (OHP) transparencies. The essential factor governing their use, as with all instructional aids, is that the content supports the lesson.

Motion pictures and video appeal to students, while packaged lessons appeal to instructors; care should be exercised to ensure that the lesson is being supported – not supplanted. Motion pictures and video should be previewed and summarised by you before use.

Films and video are good for gaining and maintaining attention, but they do not lend themselves well to the interactive learning process. Slides or OHP transparencies combined with your presentation provide greater opportunity for interaction.

Use of projected materials requires careful planning and rehearsal by you to adjust equipment, lighting and timing.

Computer-based instruction

At this time, the computer is by far the most versatile kind of aid available to instruction⁹³.

Computers combine the features of film or audio in gaining and maintaining attention and can provide simulation and interactive feedback. With the development of touch-screen technology, exciting possibilities for interactive instruction and feedback have become possible⁹⁴. At first glance the computer appears to incorporate all the considerations of effective instruction. However, the computer still lacks the ability to provide for an individual's social and egoistic needs. For example, belonging, appreciation and recognition. For this reason it is worth stating again that instructional aids are used in support of your delivery; they should not substitute for instruction itself.

Future developments

Recent years have seen an explosion of new materials and techniques in the field of instructional aids. The effective instructor strives to keep abreast of new devices, new materials, and their potential uses. In choosing an appropriate instructional aid, you must be receptive to new possibilities and keep in mind the learning goal to be achieved, as well as the role of the instructor in human relations⁹⁵.

⁹³ Wager & Gagne, 1987

⁹⁴ Bunderson & Inouye, 1987

⁹⁵ Anandam, 1986

Chapter 8—Role modelling

The influence of a flight instructor is so great that it merits a career path and status of its own⁹⁶. In this chapter we discuss the influence of your behaviour on that of your students.

Professionalism

Professionalism in flight instruction demands a code of ethics that is in no way related to the monetary gains. Flight instructors must strive for the highest levels of professionalism as attempts to operate otherwise as a flight instructor can result only in poor performance and deficient students. Anything less than a sincere effort will quickly be detected by the student, destroying your effectiveness.

Professionalism also includes a flight instructor's public image. In the past, flight instructors have all too often been willing to accept a less-than-professional status in the public view by relaxing their demeanour, appearance and approach to their profession.

If the status of the flight instructor in the general aviation industry is to be upgraded, it must be done through the efforts of flight instructors themselves.

The professional flight instructor commands the respect of associates and, most importantly, delivers more effective instruction.

Sincerity

The student pilot accepts the flight instructor as a competent qualified teacher and expert pilot. Attempting to hide inadequacy behind a smoke screen of unrelated instruction will make it impossible to command the respect and attention of the student; the professional flight instructor should be straightforward and honest.

In addition, instruction that emphasises safety will be negated if you appear to ignore your own instruction, eg, taxiing quickly, or descending below minimum altitudes.

The same applies to your insistence on precision, accuracy and smoothness of handling. The professional instructor is constantly under scrutiny and is expected to excel in aircraft handling.

Personal appearance and habits

Personal appearance has an important effect on the professional image of the instructor. Today's aviation customers are people who expect their associates to be neat, clean and appropriately dressed. It is not intended that the flight instructor should assume attire foreign to the flight environment, but as you are engaged in a learning situation, often with professional people, the attire worn should be appropriate to a professional status.

Personal habits have a significant effect on the professional image. The exercise of common courtesy is perhaps the most important of these. A flight instructor who is rude, thoughtless, impatient or inattentive cannot hold the respect of the students, regardless of piloting ability. Young, confident flight instructors need to give careful consideration to these points when dealing with students older than themselves.

⁹⁶ Telfer, 1993

The professional instructor maintains a genuine interest in the student's learning. Under no circumstances should you do or say anything that is derogatory to the student. Acceptance rather than ridicule, and support rather than reproof will encourage learning, regardless of whether the student is quick to learn or is slow and apprehensive. Criticising the student for not learning is not unlike a doctor criticising a patient for not getting well and is totally unacceptable from a professional.

The professional image requires a calm, thoughtful and disciplined demeanour. Frequently countermanding directions, reacting differently to identical errors, and demanding unreasonable performance or progress should be avoided.

On rare occasions a personality conflict may arise between instructor and student. If, for any reason you suspect this, you should discuss the problem with your supervisor who has the experience to confirm your suspicions or offer alternative teaching methods to overcome conflict.

Cleanliness of body and breath is important to flight instruction. The cabin is a close, tightly sealed area, where an instructor and student work in close proximity and where little annoyances provide serious distractions from the learning task. Likewise, the flight instructor should not be subjected to body odour from the student. If the role model example set by you is not perceived by the student, some honest discussion may be required. Once again, it is best to discuss the resolution of this problem with your supervisor.

Safety and accident prevention

The flying habits of the flight instructor, both during instruction and as observed by students, have a direct effect on safety. Students consider their flight instructor to be a paragon of flying proficiency whose flying habits they, consciously or unconsciously, attempt to imitate. For this reason, a flight instructor must meticulously observe the safety practices taught to the students, such as using full runway length for takeoff.

A flight instructor must carefully observe all regulations if a professional image is to be maintained. An instructor, who is observed to fly with apparent disregard for loading limitations, weather minima or runway length creates an image of irresponsibility that many hours of conscientious flight instruction cannot correct.

Self improvement

“The input of aviation instruction is for as long as a pilot flies”⁹⁷. Professional flight instructors must never become complacent or satisfied with their own qualifications and ability. They should be constantly active and alert for ways to improve their qualifications, teaching effectiveness and the service they provide to students. Flight instructors are considered authorities on aeronautical matters and are the experts to whom many pilots refer questions concerning regulations, requirements and operating techniques. It is essential that you maintain current copies of Civil Aviation Rules and their associated Advisory Circulars. A flight instructor who is not completely familiar with current pilot issue and rating requirements cannot do a competent job of flight instruction. However, you are not alone; if confronted with a question to which you do not know the answer, turn to your supervisor. Better, make use of your supervisor to get answers before the questions arise. Your supervisor (probably your role model) is there to assist you – and has certified your logbook to this effect.

⁹⁷ Telfer, 1993, p.6

There are many means of self-improvement available to flight instructors. Aviation periodicals, recognised texts, seminars and papers offered by Massey, Auckland, Wellington and Otago Universities, instructional techniques and advanced instructional techniques courses as well as libraries are all valuable sources of information for flight instructors.

Although the recommended reference texts are expensive, a reference library is as essential to the professional instructor as a navigation computer is essential to the professional pilot.

Flight instructors have a tremendous influence on their student's perception of aviation in general and piloting in particular. The level of professionalism shown by flight instructors in the way they conduct themselves and the attitudes they display directly affect their student's flying.

The Lessons

Pre-Flight Briefings

Introduction

The sample pre-flight briefings given here are adequate for the purpose of Category C Flight Instructor Issue Flight Test.

The novice instructor **must** realise that there is **no** standard briefing because there is **no** standard student.

These pre-flight briefings then, are a guide to the novice instructor, and their content and breadth should not be considered comprehensive. For example, no briefing on the use of the aircraft radio is given here, but this does not mean that none is required. In addition, these briefings are very generalised, and some modification will be required to meet the operating requirements of specific aircraft types.

Detailed information and some formulae have been included in the academic considerations of each briefing. These are only included to give the novice instructor a broad appreciation of the reasons behind the contents of the airborne sequence. They are not meant to be written out in full nor necessarily discussed during the pre-flight briefing. In addition, suggested briefing introductions, comments or even the suggested briefing layouts are not required to be delivered verbatim.

How much detail, background information or theory is added, and which parts are deferred or arranged differently, is the responsibility of the **qualified** instructor.

The specific ability to modify the pre-flight briefings with regard to the student's previous experience, the conditions on the day, and the objectives, is what is usually examined during the upgrade flight test from Category C to Category B Flight Instructor.

The recommended pre-flight briefing reference texts for the Category C Flight Instructor are: this guide and the *Flight Instructors Manual* (Campbell, 1994). Many other flight training references are available and acceptable as training aids. In the interests of standardisation, however, where **conflict** occurs, only the above quoted reference texts are accepted.

The sections of Campbell's *Flight Instructors Manual* entitled Instructor's Guide, Long Briefing and Flight Demonstration provide considerable detailed information about each exercise and are highly recommended reading. That manual, however, is based on the air force system of a long mass briefing (Long Briefing) of anything up to one and a half hours. That briefing would be delivered, up to a week in advance, to a large group of students who are all at the same stage of the syllabus, and it is generally not suitable for general aviation use, except perhaps in the case of night flying. The short pre-flight briefing recommended by Campbell is of ten to fifteen minutes duration, delivered just before flight, and it is based on the student's knowledge of the long brief. It is this short pre-flight briefing that this guide attempts to modify, not only for the Category C Issue Flight Test, but also as an everyday, useable, general aviation pre-flight briefing for delivery within the generally accepted time limit of 30 minutes.

Under Category C Issue Flight Test conditions, it is common practice, and acceptable, for the pre-flight briefing to take up to one hour to deliver.

The recommended reference text for the theory of flight is *Mechanics of Flight* (Kermode, 1996).

The recommended reference text (for flight instructors) for human factors considerations is *Human Factors in Flight* (Hawkins, 1993).

The sequence and contents of the briefings presented here follow a generally accepted pattern. However, the Chief Flying Instructor (CFI) of each training organisation has final discretion over the sequence and briefing content used within their own organisation.

The Pre-Flight Briefing

General

Before beginning a pre-flight brief you need to know the student's past experience in order to give relevance to the lesson. This may be simple enough to achieve if the student is known to you, has completed a post-flight questionnaire relating to their last lesson or has no previous flight experience. Where the student has previous flight experience and is not known to you, research of the student's anecdotal records will be required. Where these are not available, nor is the student's past instructor, the student's logbook forms a valuable, if limited, reference.

Where the student with past flight experience is unknown to the organisation, the CFI generally conducts an evaluation flight to assess the student's goals, values, self-concept and position within the syllabus. The CFI then provides you with the new student's relevant details.

The use of abbreviations during the briefing, for example, A/C for aircraft, is common and acceptable as long as the meaning of the abbreviation is explained.

Each pre-flight briefing has a title and is discussed under five or six headings.

The Title

Typically the title is a very brief statement. Although the title may clearly convey to you what the lesson is about, it may not for the student. As soon as the subject is introduced a verbal explanation of what the lesson is about is given, showing relevance and relating it to past experience. The introduction sets the scene for what could be either an interesting briefing during which the student is receptive – or a boring, unpleasant experience.

Objective

The lesson objective should state what the student should be able to do at the end of the lesson. In the pre-flight briefings given here, no performance parameters have been stated. When adding these to the objective, you must consider the student, the aircraft and the conditions on the day, so that the objective is achievable.

As many flight exercises are simulations, it is important to keep in mind the requirements of the **lesson** objective so that the student is able to achieve the lesson outcome without endangering the aircraft. For example, the objective of the forced landing **exercise** is not to make a successful landing, because the student must land to achieve that objective.

Likewise the use of the word safe in the objective should be avoided. Safety and being safe is a concept which is difficult to observe or measure. Promoting safety in general is desirable, and it should be emphasised that all flight operations should be conducted in a manner which enhances safety. However, as safety is not observable or measurable it is not used in the **lesson** objective.

Principles of Flight or Considerations

Under the heading of Principles of Flight (P of F), the basic principles of flight **relating to the air exercise** are discussed. This means that only simple explanations are used. These should **directly** support the air exercise. This is not an opportunity for you to discuss everything they know on the subject, nor is it a requirement of the flight test **during the briefing** (a separate examination of your knowledge is conducted later).

The heading of Considerations is sometimes used where no direct principles of flight relate to the air exercise. It can also be used in the air exercise itself to introduce similar exercises, for example, steep turns and steep gliding turns.

Aircraft Management

Aircraft management implies a broader operational context than engine handling. It prepares the student for the operation of more complex aircraft and considers aspects of total flight management.

Information presented here is meant to relate to both the immediate air exercise and the general requirements of the aircraft operation.

Aircraft management incorporates many of the airmanship, or good aviation practice considerations that are not strictly human limitations and therefore may be inappropriate under the Human Factors heading.

There is no requirement to **find** something to put in here. For example, medium turns does not require smooth throttle movements or mixture rich, so these can be ignored **or** revised at instructor discretion.

Human Factors

Currently some form of human failure causes 70 percent of all aircraft accidents. Information presented here is meant to introduce the student to human limitations that may be observed or experienced during the air exercise, especially those areas that affect decision-making and pilot judgement.

For information on how to teach decision-making and pilot judgement refer to Simuflight (1995 and 1996).

Good aviation practice is broadly defined as common sense in the air. Good aviation practice is incorporated under the Human Factors heading because human limitations are known and can be taught, whereas good aviation practice is generally accepted as something you either have or have not. For example, good aviation practice requires a good lookout, whereas human factors describes the limitations of the human visual system and how to overcome those limitations to **achieve** a good lookout.

The **ADVISE** model (Altitude, Disorientation, Vision, Information Processing, Stress and Esprite or E'alth – health), developed by Ewing (1994), is an aid to you for considering which aspects of the human factors syllabus should be incorporated into the pre-flight briefing. For example, Altitude, is an aspect of known human limitations directly involved in climbing but not medium turns.

Air Exercise

This is the reason for the pre-flight briefing and everything presented before this point should directly support the air exercise.

Generally the air exercise will follow a sequence of entry, maintain, and exit.

Airborne Sequence

Generally, the airborne sequence is:

1. Demonstration
2. Follow me through
3. Instructor talks student through
4. Student practices

The demonstration is a physical statement of the lesson objective: “Here is what you will be able to do at the end of this lesson”.

The follow through is a patterned breakdown, by you, of the actions required to complete the manoeuvre or part of the manoeuvre.

The instructor talk through is a re-assembly, by the student, of the actions required to complete the manoeuvre with instructor assistance.

Student practice involves evaluation by both instructor and student as to whether or not the student’s performance achieves the lesson objective. Remember that perfection or a performance within **flight test** parameters, is not necessarily a part of the lesson objective.

Student practice should not be continued beyond the point at which the objective is achieved.

Patter

The airborne patter should follow the same sequence as the briefing, using the same words and avoiding the inclusion of material or exercises that were not covered in the briefing. In most air exercises, the movement of the aircraft controls can be slowed down, permitting synchronisation of the patter with aircraft movement. Where this is not possible, for example, with spinning, you must be careful not to include too much verbal detail in one demonstration.

Control Inputs

Your flying should be accurate and control movements should be smooth and coordinated at all times. The use of jerky, abrupt or uncoordinated control movements should be avoided wherever possible. For example, when discussing the suitability of a particular field for forced landing practice, the aircraft should be positioned such that both the student and instructor can clearly see the field in a gentle turn and a constant altitude maintained. Poor altitude control, or rolling the aircraft with aileron and keeping straight with rudder, in an attempt to keep the field in sight, resulting in crossed controls, should not be demonstrated.

Aircraft Control

You are the pilot-in-command. The safety of the aircraft, crew and passengers is of paramount importance to the pilot-in-command. However, achieving the maximum benefit from the learning experience is of paramount importance to the professional instructor.

The decision to give the student control or to take control yourself can only be based on experience. The professional flight instructor retains situational awareness at all times and never allows the safety of the flight to be compromised.

Generally, when handing over control to the student, make sure the student realises they have full control by removing your hands from the control wheel, column or stick, and throttle as well as removing your feet from the rudder pedals. Follow-me-through exercises are used to give the student insights to control movements and build confidence. However, when handing over control, often removing your feet from the rudder pedals is difficult or overlooked, and this can lead to subconscious control inputs that only **undermine** the confidence of the student.

In some exercises maintaining a very light feel on the rudders may be beneficial to your **assessment** of student performance. Great care must be taken, however, not to lead or override the student's inputs.

Parallax Error

Parallax error results from viewing the pilot's instrument panel at an oblique angle. Its effects are most noticeable with regard to balance, aligning the Directional Indicator (DI) and angles of bank on the Artificial Horizon (AH).

As a result of side-by-side seating a similar effect occurs when viewing aircraft attitude and reference points in relation to the aircraft nose. Remember it's what the student sees that is of prime importance.

Airmanship

"The teaching of airmanship is above all a matter of clear...example displayed by the instructor."⁹⁸.

Continuity

Where convenient (refer CFI) the manoeuvre to be taught in the next lesson is demonstrated at the end of each air exercise.

The Debriefing

No skill is more important to an instructor than the ability to analyse and judge student performance. The student quite naturally looks to you for guidance, analysis, appraisal, suggestions for improvement and encouragement.

A debrief may be either oral, written or both, and it may be used in the classroom as well as the aircraft. It should come immediately after a student's performance, while the details are easy to recall.

Two common misconceptions about the debrief should be eliminated from the beginning. First, as with all evaluation, a debrief is not a step in the grading process, it is a step in the learning process. Second, a debrief is not necessarily negative in content, as it considers the good along with the bad.

A debrief should improve the student's performance and provide them with something constructive to work and build on. It should provide direction and guidance to raise their level of performance.

⁹⁸ Campbell, 1994, p.7

Characteristics of an Effective Debriefing

Objectivity

The effective debrief is focused on student performance and should not reflect your personal likes and dislikes. Instructors sometimes permit their judgements to be influenced by their general impressions of the student, favourable or unfavourable, to such a degree that it influences objectivity. If a debriefing is to be objective, it must be honest. It must be based on the performance as it was, not as it could have been or as you and student wish it had been.

Flexibility

You must fit the tone, technique and content of the debriefing to the occasion and the student. Again and again, you are faced with the problem of what to say, what to omit, what to stress, and what to minimise. The debriefing challenges you to determine what to say at the proper moment. The effective debrief is one that is flexible enough to satisfy the requirements of the moment.

Comprehensiveness

A comprehensive debriefing is not necessarily a long one, nor must it treat every aspect of the performance in detail. You must decide whether the greater benefit will come from a discussion of a few major points or a number of minor points. An effective debrief covers strengths as well as weaknesses. How to balance the two is a decision that only you can make.

Constructiveness

A debriefing is pointless unless the student profits from it. The student needs to be informed of how to capitalise on things that are done well. Also, it is not enough to identify a fault or weakness, you should give positive guidance for correction.

Organisation

Unless a debrief follows some pattern, a series of otherwise valid comments may lose their impact. The debrief should follow a logical pattern and make sense to the student as well as you. The pattern might be the sequence of the performance itself, or it might begin with the point where a demonstration failed and work backward through the steps that led to the failure. A success can be analysed the same way. Whatever the organisation of the debriefing you should be **flexible** enough to change it if the student cannot understand it.

Considerate

An effective debrief reflects your consideration of the student's need for self-esteem as well as recognition and approval from others. You should never minimise the dignity and importance of the individual. Ridicule, anger or fun at the expense of the student has no place in a debriefing.

Specific

Your comments and recommendations should be specific, not generalised. A statement such as, "Your second steep turn was better than your first", has little constructive value unless you explain specifically why, how, or in what area the student improved. At the conclusion of the debrief the student should have no doubt what they did well and what they did poorly and, most importantly, specifically how they can improve. If you have a recommendation in mind, it should be expressed with firmness and authority in terms that cannot be misunderstood.

From the above it should be apparent that the ability to conduct an effective debrief is not something that comes naturally. It requires considerable training and practice. Experience

has shown that newly qualified flight instructors tend to over-concentrate on performance errors, which are often minor.

The debrief should begin with an opportunity for the student to state how well they thought they did in achieving the objective.

If the objectives were met, you are presented with the opportunity to give immediate positive feedback.

If the objectives were not met, and the student knows why or can explain how they might achieve the objectives in subsequent flights, again the opportunity for positive feedback exists.

The opportunity for the student to speak freely about their performance may provide you with insights about the student that may not otherwise be voiced (their fears or misconceptions).

If the objectives were not met, highlight the main features of the exercise or performance, accentuate the positive, give praise where appropriate, and gradually build on your experience to analyse the student's performance more specifically and constructively.

The Aeronautical Decision-Making (ADM) aspects of the lesson should also be considered in the debrief⁹⁹.

It is highly recommended that you take advantage of the direct supervision period and ensure that your supervisor attends the debriefing. Your supervisor can debrief you, in private, on your performance. Remember, the debrief is not a step in the **grading** process but a step in the **learning** process.

Blackboard/Whiteboard Layouts

The proposed layouts are again, only a guide. They represent the finished layout and should be supplemented with the use of various aids.

Throughout this text the words control column, control wheel and stick are used interchangeably, as they all have the same function and sense of movement.

⁹⁹ Simuflight, 1996

Taxiing

It is not intended that this briefing be given as the first lesson. The purpose of the taxiing briefing is to consider the effects of the environment on the ground handling of the aircraft. These environmental factors include the surface type, slope, wind, wingtip and propeller clearance, other traffic, slipstream, seat adjustment, windscreen cleanliness, inertia and speed judgement, blind spots, aerodrome layout, instrument checks, Air Traffic Control (ATC) clearances, right of way rules and aerodrome markings.

The physical taxiing of the aircraft is usually discussed during the first lesson of Primary Control Effects. However, the considerations of taxiing as listed above are spread over the total lessons leading up to first solo. Your supervisor will examine the student's knowledge of these considerations before first solo, and it is your responsibility to ensure that the student is aware of them. Instructors should develop briefings appropriate to their aerodrome and aircraft type and ensure that all these considerations are discussed before a recommendation for first solo.

To ensure that the physical aspects of taxiing are conveyed to the student, it is recommended that the following briefing be given at a convenient time before first solo, for example, if the weather is unsuitable for the planned lesson.

Introduction

Taxiing means manoeuvring the aircraft on the ground under its own power. This requires concentration and the application of common sense, or good aviation practice, because the aircraft is less manoeuvrable than your car. It is good aviation practice never to taxi into or out of hangars and to ensure, during the pre-flight inspection, that the aircraft is in a suitable position from which to begin taxiing. There is no reverse available.

Objective

To manoeuvre the aircraft on the ground at a constant speed that is appropriate for the conditions, stopping at a nominated point.

Considerations

The considerations can be divided into three areas: speed control, directional control, and the effect of wind on control positioning.

Speed Control

On the ground the aircraft speed is controlled with the hand-operated throttle. Because of inertia, more power will be required to get the aircraft moving initially than will be required to keep it moving. Maintaining taxi speed will be affected by the surface, the slope, the wind, and the power used. Many organisations recommend a minimum power setting while taxiing to minimise spark plug fouling.

Stopping is achieved by application of both differential brakes on the main wheels, operated through the tops of the rudder pedals. Slope, surface (wet or dry) and wind also affect stopping. The method of applying and releasing the park brake should also be described.

Directional Control

Directional control is achieved through nosewheel steering connected through the rudder pedals while on the ground. It should be emphasised that these work in the natural sense – push the left rudder pedal and the nose turns to the left. If required this can be augmented by differential braking to tighten the radius of turn. The wind can affect directional control, as crosswinds will cause the aircraft to weathercock into wind as a result of pressure on the vertical tail fin. Commonly, problems experienced by the student in maintaining directional control are a result of looking just ahead of the aircraft rather than at a point in the distance.

Effect of Wind on Control Positioning

The aircraft controls should be held in the appropriate position in relation to wind direction as stated in the aircraft Flight Manual. The use of full aft elevator in a modern nosewheel training aircraft is not required nor recommended while taxiing. Attempting to prevent the propeller striking the ground through the use of full aft elevator, is generally the result of taxiing over an unsuitable surface or, more commonly, taxiing at an inappropriate speed.

Aircraft Management

Avoid using power against brake. Where a high minimum power setting is recommended by the aircraft operator to avoid plug fouling, a method known as **cadence** braking should be used. This method requires that, once the aircraft reaches an acceptable maximum taxi speed, the throttle is closed, brakes applied to stop the aircraft (or nearly so) and the minimum power setting reapplied until the maximum taxi speed is again reached.

The pilot's seating position should be adjusted to achieve full rudder deflection, and the seat locking should be checked for security. By the same token, passengers should be briefed on keeping clear of rudder pedals.

An appropriate period of engine warming should be observed before taxiing. See the aircraft Flight Manual.

Brakes should be checked by the student and/or instructor for normal operation as soon as practicable after the aircraft begins to move.

The correct taxi speed is commonly described as a fast walking pace, about 5 to 10 km/hr.

The use of carburettor heat should be avoided on the ground, as air from this source, ie, hot air, is unfiltered.

In winds of more than 5 kts, the aircraft should always be stopped facing into wind to assist engine cooling.

Taxi on centre lines, but be aware of your own and other aircraft extremities, wingtips and tailplane, and propeller slipstream.

While taxiing, the aircraft flight instruments, turn coordinator, directional indicator, compass and artificial horizon, should be checked for serviceability.

Taxiing over rough surfaces should be avoided, and the use of power should be limited over loose gravel to prevent propeller damage. Keep the aircraft moving; twice as much power may be required to recommence taxiing if the aircraft stops. If the surface looks doubtful, or excessive power (>2000 rpm) is required, stop, shut down and get assistance. Do not try to 'power' out of soft ground.

Human Factors

The effects (ADVISE mnemonic) of **D**isorientation, **V**ision and **I**nformation processing limitations on situational awareness are the prime considerations in this briefing.

Right-of-way rules, the Visual Flight Guide (VFG), maps and terminal charts (VTC) as well as windsocks have been developed to limit disorientation.

Vision is not only affected by the cleanliness of the windscreen and side windows, but also by structural obstructions of the cabin. The effect of blind spots created by the cabin structure, as well as wingtip clearance judgement, should be demonstrated.

To aid information processing, **all** flights should carry the VFG and a map or VTC. Checklists, as well as the use of a kneepad to record ATIS information, fuel endurance and clearances, will also assist in the retention and processing of information.

Checklists probably epitomise the changing influence of human factors training within general aviation. It is a known fact that humans are limited in their ability to recall information accurately from memory. The use of written checklists for normal and emergency operations in complex single-engine aircraft and light twin-engine aircraft onwards, is reasonably common in general aviation. However, basic flight training still tends to use mnemonics exclusively for all operations. What is learnt first is generally accepted as being **the** correct method, therefore, the use of checklists should be encouraged during basic training.

There are two ways to use a checklist. It can be a list of things to do, as in complex aircraft or systems, or a list to check off things that have been done, as in simple aircraft or systems. For the purposes of general aviation basic training, **the use of mnemonics is not discouraged**, rather the practice of confirming that checks have been completed, during normal operations, through **the use of a written checklist is encouraged**. Some light training aircraft have this type of checklist placarded on the instrument panel by the manufacturer. If this list does not suit your organisation's requirements, perhaps a simple laminated card attached to the back of the sun visor would suffice¹⁰⁰. Situational awareness comes from integrating all the information gathered from various sources and building a three-dimensional mental model of what was, what is, and what will be the situation. The development of this skill takes considerable and regular practice¹⁰¹.

Exercise

The exercise consists of overcoming inertia to get the aircraft moving, testing brakes, maintaining an appropriate taxi speed, turning and stopping the aircraft at a designated point.

Operation of the park brake should be demonstrated and, as appropriate, the effects of slope, surface, and wind.

¹⁰⁰ For a comprehensive study of the considerations of compiling and using checklists, see Degani & Wiener (1990).

¹⁰¹ For more information on how to teach situational awareness, refer to *Aeronautical Decision Making: A Study Manual for Instructor Pilots* (Simuflight, 1996).

TAXIING

OBJECTIVE: To manoeuvre the aircraft on the ground at a constant speed (appropriate to the conditions), stopping at a nominated point.

CONSIDERATIONS:

Factors affecting taxi speed and stopping distance

- **Inertia** more power to get started, less as the A/C begins to move
- **Slope**
- **Surface** (Grass, long, short - wet or dry / Concrete)
- **Wind** tailwind, headwind
- **Power**

Braking through differential brakes on main wheels.

Park brake operation (as applicable to type)

Directional control Rudder pedals have dual purpose

- To turn the aircraft through nosewheel steering (natural sense) & braking
- **Wind** weathercock tendency

Control positioning (use diagram from A/C flight manual)



Steering
Braking
OHP Recommended

A/C MANAGEMENT:

Seat adjusted and secured

T's and P's - suitable

Avoid using carb heat

Brake check - speed check

Avoid using power and brake together

Wing tip clearances

Slipstream - considerations

Cross rough ground at an angle

-caution gravel

Instrument checks

Stop into wind (aids cooling)

EXERCISE:

1. Moving off

- Lookout - check wingtip clearances
- Close throttle
- Release park brake
- ↑ power to overcome inertia
- Close throttle
- **Test Brakes**

2. Maintaining constant speed

- Anticipate power required
- Taxi at fast walking pace (maximum)
- Avoid using power against brake

3. Maintaining constant direction

- Look well ahead, not just over the nose

4. Turning

- Lookout
- Rudder pedals only (wide radius)
- Power as required

5. Turning in confined spaces

- Lookout
- Use full rudder
- Then differential braking (radius smaller)
- Power as required

6. Stopping

- Lookout and anticipate (nominated point)
- Close throttle
- Apply even pressure on brake pedals
- Once stopped, park brake on
- Idle at _____ rpm

7. Brake Failure

- Close throttle and steer away from obstacles
- Collision imminent FMI and Master OFF

HUMAN FACTORS:

Disorientation

- VFG & VTC
- Give way rules
- Know W/V

Vision

- Lookout
- Clean windscreen
- Blindspots

Info Processing

- Checklists
- Record ATIS and clearances
- Situational awareness, mental 3D picture

EFFECTS OF PRIMARY CONTROLS

OBJECTIVES:

1. To observe and experience the first effects of moving the aircraft primary control surfaces in flight.
2. To observe the further (or secondary) effects of moving the aircraft primary controls on their own, in flight.

PRINCIPLES OF FLIGHT:

Bernoulli's Theorem

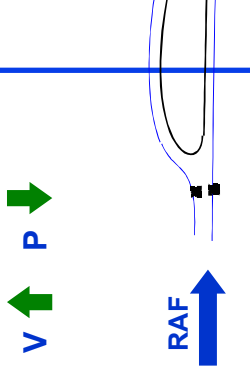

- Camber (shape)
- Angle of Attack
- Airspeed

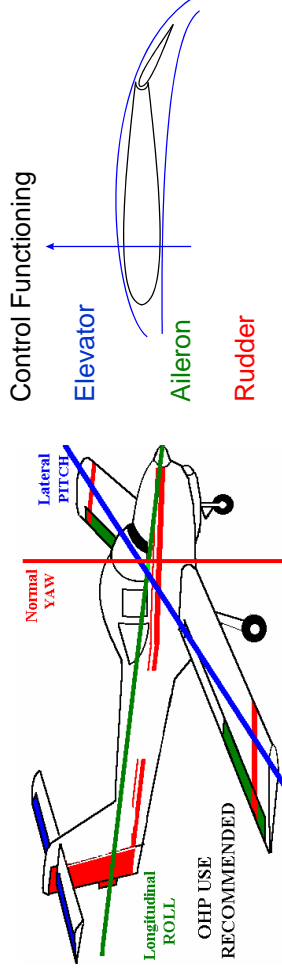

Control Functioning

Elevator
Aileron
Rudder

AIR EXERCISE:

1. Before takeoff
Revise taxiing

2. Effects of Primary Controls

Control	Input	1 st Effect	2 nd Effect	Use
Elevator	C/C back C/C forward	Pitch up Pitch down	Nil	Attitude A/S
Aileron	C/C left C/C right	Roll left Roll right	Slip — Yaw	Direction
Rudder	Pedal left Pedal right	Yaw left Yaw right	Skid — Roll	Balance

3. Airspeed

- Low airspeed - Controls light & less effective, large movements required
- High airspeed - Controls firm & effective, smaller movements required

4. After Landing

- Revise taxiing and Idle Cut Off (ICO) on shutdown

AIRCRAFT MANAGEMENT:

- Throttle _____ to increase Power
_____ to decrease Power
- Mixture Push in to enrichen
Pull fully out to ICO
- Carb heat ___hot___ cold
- T's and P's Range (green/red)
- I/You have control - follow me through



Clear of cloud

HUMAN FACTORS:

LOOKOut - BLINDSPOTS

Memory limits - checklists

Orientation - Local landmarks

I'm Safe

Effects of Primary Controls

This briefing deals with the first aerodynamic effect, and the second or further aerodynamic effect, of using the aircraft primary flight controls, ie, elevator, aileron and rudder – **on their own**.

As this is commonly the first formal pre-flight briefing, a short explanation of the sub-headings to be used should be carried out as well as the normal introduction.

Introduction

Primary flight controls are the elevator, ailerons and rudder. When these are deflected in flight the aircraft moves about one or more of its three axes. We need to know what effect these controls have on the aircraft flight path in order to accurately manoeuvre the aircraft from place to place. We also need to see the effect of moving each of these primary flight controls individually, so that any unwanted secondary effect can be countered through coordinated use of the primary flight controls.

Objectives

1. To observe and experience the first effects of moving the aircraft primary control surfaces in flight.
2. To observe the further (or secondary) effects of moving the primary controls, on their own, in flight.

Principles of Flight

On the ground, the aircraft speed is controlled by a hand operated throttle. Steering is achieved through a steerable nosewheel and braking through main wheel brakes (Overhead Projector [OHP] use is recommended).

Introduce the term **lift** and **aerofoil**. Describe the production of lift with reference to Bernoulli in the simplest possible terms; for example, if the speed of air is increased the pressure will be reduced and vice-versa.

Describe the effects of aerofoil shape, angle of attack and airspeed on the production of lift.

Describe the three axes of the aircraft, – lateral, longitudinal and normal – and the movement about those axes (OHP recommended).

Drawings or overheads should be gradually built up and colour coordinated; for example, the lateral axis, the elevator and the word **pitch** all coloured blue.

Describe how deflection of the controls changes the shape and/or angle of attack, affecting lift and producing the first aerodynamic effect. Start with the elevator, as this is the easiest to describe.

Aircraft Management

The sense of movement of the engine controls should be discussed. Throttle – pushing in or forward for an increase, pulling out or back for a decrease. Carburettor Heat – down or out for hot, up or in for cold. Mixture – forward or in for rich, down or out for lean. The **purpose** of these controls is not explained at this time. Explain that when the mixture

control is pulled fully out the fuel supply is cut off from the engine. This is called Idle Cut Off (ICO) and is normally used to stop the engine (not the ignition key), removing all fuel from the cylinders preventing seepage past the rings and subsequent contamination of the oil. This will be demonstrated on shutdown at the end of the lesson.

Generally temperature and pressure gauges, such as oil, cylinder and fuel, have a normal operating range depicted by a green arc. Red lines indicate operating limits, yellow arcs the cautionary ranges, and often white lines or arcs for other purposes (refer to the aircraft Flight Manual for specifics).

From the above it should be obvious that a large-scale photograph of the aircraft instrument panel and/or cabin layout will be an invaluable aid.

Knowing who is physically flying the aircraft is a major management concern. The practice of verbally stating “I/You have control”, although critical in aircraft with tandem seating, is still relevant to side-by-side seating. In addition, the meaning of “follow –me through” should be explained; for example, “I want you to place your hands and feet lightly on the controls and feel what I’m doing, but I retain control.”

The aircraft is manoeuvred in the air by visual reference to ground features and the horizon. Therefore, cloud must be avoided and the ground or water kept in sight at all times. Some **major** features in your local area, as well as the approximate directions of north, south, east and west will be pointed out in the air.

Human Factors

The limitations (ADVISE mnemonic) of **V**ision, **I**nformation processing and **S**tress are the prime considerations for this briefing.

The limitations of vision on lookout effectiveness should be discussed as well as the restrictions imposed by the cabin structure and how to overcome this through head movement.

The effects of apprehension or stress and information overload should be discussed in relation to human information processing capabilities and their effects on performance. The short-term memory can hold only 7 items \pm 2. The benefits of regular practice and a checklist to decrease apprehension and improve information retention should be stressed.

I’M SAFE

The I’M SAFE checklist should be introduced for the student to complete, before leaving home for their next lesson. Some of the human factor considerations of this checklist are given below; however, these are not comprehensive given the broad field of human factors.

I – Illness, do not fly when feeling unwell as the decision-making process will be adversely affected and this will not only degrade the learning experience but affect all phases of flight.

M – Medication, how will the effects of medication being taken be altered by the flight environment; for example, altitude. In addition, why is medication being taken, am I unwell?

S – Stress or worry takes up valuable space in the short-term memory. Getting into an aircraft straight after an argument with your boss, or with other personal worries, affects your information processing capabilities adversely.

A – Alcohol, even in small amounts, adversely affects brain functioning. Mixed with altitude and the dynamic three-dimensional pursuit of aviation, it is deadly and a major good aviation

practice no-no. Safe periods of abstinence before flight vary with the individual and the amount consumed. To remove all effects of alcohol from the system takes a surprisingly long time. As a guide, three to four beers – takes approx. 12 hours, while consuming only a little more than this can increase the period to as much as 48 hours¹⁰².

F – Fatigue affects not only motor skills but also mental skills. Adequate rest is essential for quality information processing and decision-making¹⁰³.

E – Eating the correct food in a balanced diet and drinking water at regular intervals to prevent dehydration obviously affects fitness. Many people are not aware of the adverse effects that poor eating habits or dehydration can have on the decision-making process.

In addition, the P'M SAFE checklist should be prominently displayed in the briefing room for quick reference before flight.

Air Exercise

The method of taxiing the aircraft under its own power, stopping and turning should be described.

The effect of movement of each of the primary controls in flight is revised, with emphasis on the sense of movement of the control column and rudders – not the sense of movement of the control surfaces themselves. What the pilot/student sees as a result of control movement is what is important; for example, pulling back on the control column pitches the nose up. Great emphasis should be given to the association between control movement and the **natural sense**. For example, rotating the control column to the right will cause the aircraft to roll to the right.

In normal flight these movements are generally related to the horizon. However, this is not strictly correct, as the control movements always have the same effect in relation to the pilot. For example, when banked at 90 degrees, rudder will yaw the nose to the pilot's left or right but up or down in relation to the horizon. Since we avoid extreme attitudes in **basic** training, this distinction **does not have to be**, nor is it normally, emphasised.

The further or secondary effects of movement of the primary controls on the flight of the aircraft are discussed next. The emphasis here is on aerodynamic effects, sometimes known as aerodynamic cross coupling. When a control movement is made, **on its own**, movement initially occurs around one axis, followed by an undesired movement about another axis. The main point is that these effects only occur when the control is used **on its own**.

There is **no** further or secondary effect of elevator. When aileron is used on its own, however, the aircraft will roll, slip and yaw towards the lowered wing. When rudder is used on its own, the aircraft will yaw, skid and roll in the direction of yaw. In both cases the aircraft will, **if the controls are left alone**, enter a spiralling descent. The initial slip or skid can be demonstrated with the use of a model, but it will be difficult to detect in the air. The balance ball will indicate these effects, but you may not wish to draw the student's attention to this instrument at this time.

It should be emphasised that these further or undesirable effects of ailerons and rudder can be eliminated through coordination of these controls, and will be dealt with in later lessons. In this lesson, your purpose is to demonstrate to the student that these secondary effects are there.

¹⁰² Ewing, 1993

¹⁰³ Reinhart, 1988

Basic flight training is based on the concept of attitude flying by visual reference. It is important to introduce the student to the concept of attitude, being the relationship between the nose or instrument panel coaming and the horizon, as early as possible. To this end, what the primary controls are used for should be discussed next – in simple terms.

Elevator is used to adjust the aircraft attitude in pitch, and the resultant nose-high or nose-low attitude will directly affect aircraft speed. The use of an attitude window to demonstrate this is highly recommended. Aileron will roll the aircraft and is used to change direction, like a bike leaning into the corner. Rudder will yaw the aircraft and is used mostly to achieve balanced flight. How to use these controls will be dealt with in later lessons.

The effect of airspeed on the feel of the controls, the aircraft response rate, and the amount of control movement required to bring about any change of flight path are discussed next. Commonly, the analogy of holding your hand out the car window and moving it from horizontal to vertical at various speeds is used to describe this effect.

At low airspeeds, typically a high nose attitude, the controls are easy to move, have little effect and require large movements to bring about a change of flight path. They are less effective. Describing the control feel, at low speed, as “sloppy” is not encouraged, especially by the aircraft manufacturer.

At high airspeeds, typically a low nose attitude, the controls are harder to move, very effective and require only small movements to bring about a change of flight path.

Airborne Sequence

During the pre-flight inspection, only the major features of the aircraft, and the primary controls and movements should be pointed out. Notice that, while full control movement is acceptable on the ground, because the primary controls are situated at the extremities (thus providing a large moment arm), only small movements are required in normal flight.

Correct seating should be ensured and the limitations imposed on the lookout as a result of the cabin structure noted.

Initial attempts at taxiing may be enhanced by permitting the student to operate the rudder pedals while you hold the control column, in the desired position for the wind conditions and operate the throttle. Gradually hand over the operation of throttle, brakes and control column to the student. Most students will early on attempt to steer the aircraft on the ground by rotating the control column – as in a car. They will soon discover that this has no effect on the aircraft. With maybe a gentle reminder or two, they will learn to keep the control column neutral and use their feet on the rudder pedals. The student should not be embarrassed, as it is simply a human factor!

Major ground features can be pointed out and approximate directions of north, south, east and west.

Before commencing any demonstration, ensure the student is looking in the right place, ie, outside. If the student is looking at the rudder pedals they are unlikely to see the first effect, much less any further effects.

The primary flight controls and their effects are demonstrated one at a time, with emphasis on the natural sense. Directly after each demonstration, the student is permitted, to operate each control one at a time. You **must** ensure that during the demonstration and student practice of rudder movement that the wings are held laterally level with aileron. Otherwise the student will see the more obvious roll rather than a pure yaw.

The aircraft should be trimmed to fly hands-off and a big point made of removing feet from rudders as well as the lightest of finger and thumb grips maintained on the control column. You must ensure that the natural tendency to increase backpressure as the aileron is applied is overcome, otherwise the yaw will not occur. Secondary effects only occur when the primary controls are used **on their own**. Drawing the student's attention to the outside reference point, the aircraft is rolled with pure aileron using only finger and thumb. The slip is very difficult to see and may be ignored. However, the yaw and resultant spiral descent should be apparent.

You should ensure three things – that only moderate angles of bank are used, that the ease with which the spiral descent can be stopped at any time through coordinated control use is emphasised, and that the further effects are demonstrated in both directions.

Once the aircraft has been returned to normal flight, the further effect of rudder should be demonstrated. Gentle application of rudder is all that is required. Once again the skid is difficult to see and can be ignored but the roll and resultant spiral descent is obvious.

Finally, the use of elevator to select an attitude, and its resultant effect on airspeed, should be demonstrated. Nose-high attitude – low or lower airspeed, nose-low attitude – high or higher airspeed. At this stage there is no requirement to refer to any specific attitude, for example, level or climbing attitude. During this demonstration the throttle **should not** be moved, so as to make it quite clear that it is the attitude that directly affects the airspeed.

In each case (low and high airspeed) the student should note the feel and response of each primary control. The nose-high, low-air-speed case is commonly carried out first to conserve height. Although any slipstream will affect the feel and response of elevator and rudder in most single engine aircraft, the average student on their first lesson will not detect it. It is highly unlikely that the student under these conditions will notice any difference at all regardless of the power setting. Therefore, the student will need to be convinced verbally of what they feel. This is achieved by modulating your voice as each control is moved. For example, low airspeed, elevators light, less effective, **BIG** movements required; high airspeed, elevators **firm**, **VERY** effective, small movements required. The benefit of a constant power setting to give a clear demonstration of **attitude to control airspeed** far outweighs the considerations of control feel and response.

You **may** demonstrate at the end of this sequence that all three controls work in relation to the pilot and not the horizon by rolling in some bank, pitching the nose up or down and yawing left or right at the same time. The student should then be permitted to operate all three controls for a short period.

To check for understanding, you should not ask the student to “pull back on the control column”. Instead you should ask the student to “pitch the nose up”.

You should take control and **demonstrate** the further or secondary effects of moving the primary controls **on their own**. This is a pure demonstration. No follow-through or student practice is conducted, as the use of the controls **on their own** is something you want the student to avoid throughout their training¹⁰⁴.

After landing, allow the student to revise taxiing and to move the mixture control into ICO on shut down.

¹⁰⁴ Campbell, p.4-31

Debrief

Comments are given here as a guide to the novice instructor on how to go about the debrief while gaining the experience needed to expand their teaching. No further comment on the debrief of subsequent lessons will be given in this guide.

The debrief is an opportunity to revise the exercise, and for both you and the student to reflect on whether the objectives have been met.

In this case, did the student taxi the aircraft under its own power – this certainly should have been achievable. How well did they do? Since no parameters were set, only praise for the student's efforts can be delivered, but, see under headings Give credit when due (Chapter 2) and Preparation (Chapter 4).

Did the student observe and experience the effects of the aircraft primary controls in flight?

Did the student observe the further effects of movement of the primary controls on their own in flight?

If you require verbal confirmation from the student that the objective has been achieved, questions should be phrased to test understanding. Do not ask if the student observed the secondary effects of the primary controls. Preferably, ask the student to describe the further effect of one, or each, of the primary controls (see Chapter 6)

Effects of Ancillary Controls

Introduction

Ancillary controls are things such as throttle, flap and trims. We need to know how to operate each of these correctly and what effect their operation will have on the flight of the aircraft. If the effect of using these controls is known, then with practice, any adverse side effect of operating these controls can be countered.

Objective

To experience the effects of operating the aircraft ancillary controls in flight.

Principles of Flight

Slipstream is described as the column of air being forced back by the propeller and the primary controls it affects are pointed out. It should be noted that slipstream is present whenever power is being used, regardless of the aircraft speed. The mental comparison of walking directly behind the aircraft, as against holding a wingtip as it taxis, may be used to help the student visualise the effect of this airflow.

The rotational nature of the slipstream should be described next and the resultant impact on the tail fin. Since the aircraft spends most of its time in cruise, the manufacturer generally offsets the tail-fin to negate the resultant yawing tendency. Therefore, at any power setting other than normal cruise, the aircraft will want to yaw in one direction or the other.

Describe where flap is located on the aircraft, their mode of operation (electric or manual), as well as the various positions to which they can be selected. It should be noted that flap up means flush with the wings, ie, they do not extend above the wing.

The effect of flap, through distinctly changing the shape of the wing is described next. The resultant changes to lift, drag and pitch are described. Commonly, in high-wing aircraft, the nose is pitched up on application of flap, and on low-wing aircraft the nose is pitched down. The reverse occurs in each case when flap is raised. In some aircraft types the nose will pitch up on the initial application of flap and down on application of subsequent flap settings. This briefing will describe the actual pitch change that the student will observe as a result of using the flap, on their own, in the aircraft model being flown.

Finally, the purpose of trim tabs and how they work is discussed. It should be emphasised that trim tabs are used to provide sufficient force to hold the primary control surface in the desired position; they are not used to alter the primary control surface's position. It should also be noted that trim tabs **may** be provided on all three primary controls.

Aircraft Management

The use of smooth throttle operations is emphasised.

The use of the mixture control to alter the fuel/air ratio and the normal full rich position of the mixture control for training operations is discussed. The leaning of the mixture will be covered in later lessons.

The purpose of the carburettor heat control should be covered in detail (OHP use recommended). This will incorporate the **reasons** for carburettor ice forming, the

symptoms of its formation, and the **cure**. In addition, the reason for applying carburettor heat **before** closing the throttle, and the conditions under which carburettor ice is most likely to form, should be described¹⁰⁵.

As introducing warm air into the carburettor alters the mixture, it is not normally used at high power settings.

The importance of monitoring temperatures and pressures for normal readings should be explained. This is not just a matter of ensuring they are in the green, but requires some interpretation of instrument readings in relation to the phase of flight. It may sometimes be normal to taxi with oil temperature below the green range (see aircraft Flight Manual). On the other hand, it would not be normal to see the oil temperature near the top of the green range after a prolonged descent, even though it's in the green.

The structural airspeed limit for flap extension, and the normal operating range, white arc, should be explained.

The method of managing the cabin environment, through the operation of cabin heater and fresh-air vents, should be discussed.

The lateral boundaries of the training area and the importance of managing the flight to remain within them should be discussed.

The importance of managing the flight to comply with the requirements of Visual Flight Rules (VFR) should be discussed in relation to flight outside controlled airspace below 3000 feet on the altimeter, or within 1000 feet of the ground. Over subsequent briefings the various aspects of VFR flight will be discussed. It is vital that you demonstrate compliance with the various requirements of VFR (see Chapter 8 – Role Modelling).

The importance of inspecting the aircraft before flight should be emphasised and a demonstration of the full aircraft preflight inspection given.

Human Factors

The effects (ADVISE mnemonic) of **V**ision and **I**nformation processing limitations on situational awareness are the prime considerations in this briefing.

While information processing limitations are very relevant and may be revised or expanded on, the limitations of VFR and the see-and-be-seen principle on which it's based deserves prime consideration. Thus the limitations of the human visual system to detect small stationary objects, as against the ability of peripheral vision to detect movement, should be discussed in depth¹⁰⁶.

The method of using the clock code to report the relative position, as well as the relative height and distance of other aircraft, should be described. Aircraft that appear above the horizon are higher, on the horizon are at the same level, and below the horizon are lower. Distance is judged from the known size of the object and is prone to perception errors. For example, a Boeing 747 at 10 miles can look like a Cherokee 140 at 2 miles.

The importance of completing a personal preflight inspection (before departing for the aerodrome) is revised through the I'M SAFE checklist.

¹⁰⁵ Refer to the detailed description given in Campbell (1994, p.4-22).

¹⁰⁶ Hawkins, 1993

Air Exercise

During this exercise the lateral boundaries of the training area will be pointed out.

The effect of slipstream, normally over the elevators and rudder, is described in relation to high or idle power settings at a constant airspeed. At high power the slipstream is increased, and the elevator and rudder are more effective; conversely, at idle power they are less effective. Because the ailerons are situated outside the slipstream their effectiveness does not change with increasing or decreasing slipstream.

Power can be increased or decreased. With an increase in power the aircraft will pitch up (for reasons that will be explained in a later lesson) and the nose will yaw to the left for the reasons given in the Principles of Flight. For the reverse reasons, reducing power will result in a pitch down and yaw to the right.

When flap is lowered, lift and drag are increased, which causes the nose to pitch _____. The opposite effect will occur when flap is raised.

A description of the use of trim or trims completes this briefing. The method of trimming should be described. Commonly, holding the elevator back – trim back, holding forward – trim forward. Similarly, holding right rudder pressure – move or rotate rudder trim to the right.

Airborne Sequence

During the preflight inspection both fixed and adjustable trim tabs, and the effect flap has on the shape of the wing, should be pointed out.

As the opportunity arises, the lateral boundaries of the training area should be pointed out.

Although the effect of slipstream is present at all airspeeds with power on, it is easiest to demonstrate at a high power setting and low airspeed, compared with idle power at the same airspeed. You set up the aircraft for a constant low airspeed with full power on (eg, a climb). Trim. The student should be permitted to operate all of the controls, noting the **feel** of effectiveness for each.

The next step is to reduce power to idle to remove the effects of slipstream and set up the same airspeed as before (ie, a glide). Trim. Now the student again operates all controls, noting the changed **feel** of those within the slipstream.

To demonstrate the effects of a power increase or decrease, the aircraft should be trimmed hands off at an intermediate power setting. A point should be made of feet and hands being off, using only the finger and thumb, before the application of power. Ensure the student is looking in the correct place and increase power. The student should be encouraged to open the throttle. The yaw as a result of increasing power may be difficult to see, because the power range of most training aircraft is small. Preference may be given to demonstrating the effects of reducing power first and then trimming for level flight at a low power setting, for example 2000 rpm, which will provide for a bigger power change when demonstrating the effects of increasing power. In either case you should regain level flight and check the trim between each demonstration.

To demonstrate the effect of flap, an attitude should be selected for a suitable speed within the white arc. Trimmed out, hands off, flap is selected and the pitch change for the aircraft type noted. This will not necessarily require the application of **full** flap. The student may operate the flap, but you should be aware that observing the pitch change is the more

important aspect. Flap operation should not be allowed to distract the student. The effect of raising the flap, after you have re-trimmed for level flight, is then demonstrated.

The use of elevator trim to relieve control loads and maintain a constant attitude is demonstrated next. Be aware that the aircraft is trimmed for an attitude **not** an altitude nor airspeed. The student should be asked to hold a constant attitude – any one will do – you then apply trim to load the control. **Caution: do not use excessive amounts of trim in case the student suddenly lets go of the control column.** When the student can feel that they are pushing or pulling in an effort to maintain the attitude they should move the trim in the appropriate direction to remove the load.

To ensure that the aircraft is trimmed, the student should be encouraged to gradually relax their grip on the control column and, **looking outside at the attitude**, observe any change. If a change is observed, the desired attitude should first be re-selected **with the primary flight controls**, then a short pause is required while equilibrium is re-established, then re-trim and start the checking process again. As already pointed out, the student at this stage, cannot feel subtle control pressures. However, the changing attitude should be relatively easy to detect. The aim is to be able to fly the aircraft at a constant **attitude**, using only a finger and thumb grip, and this will not be achieved in one lesson.

Finally, the operation of the aircraft heater/demister and fresh-air vents should be demonstrated.

EFFECTS OF ANCILLARY CONTROLS

OBJECTIVE:

To experience the effects of operating the A/C's ancillary controls in flight.

PRINCIPLES OF FLIGHT:

Slipstream

OHP Recommended

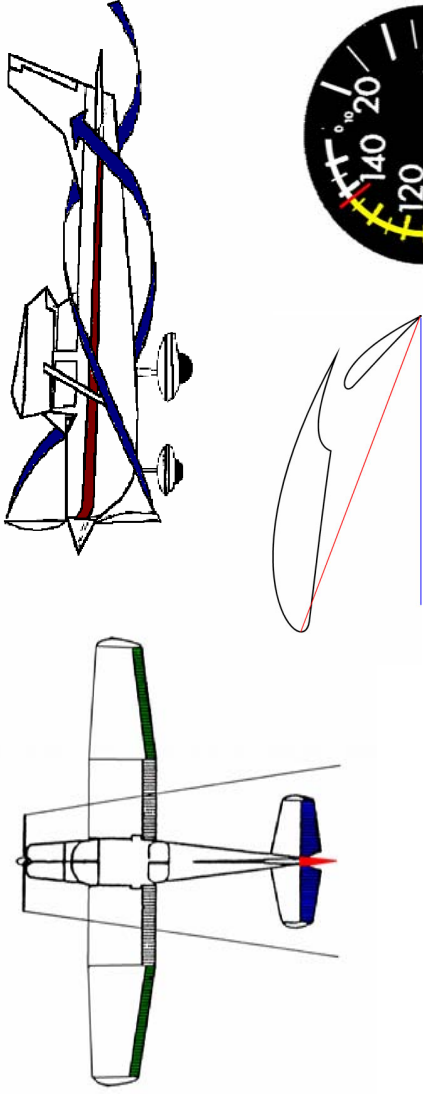

Flaps - change wing shape and angle of attack

Lift & Drag increase

Trim - is a device to relieve flight control pressures

White arc - flap operating range

AIRCRAFT MANAGEMENT:

Throttle - Smooth operation

Mixture - fuel/air mix, when training - **full rich**

Carb heat - **why ice forms, symptoms, cure**

& prevention at low rpm (OHP)

T's and P's NORMAL (green range)

Flap limits (white arc)

Cabin heat & air operation.

Training area boundaries

VFR below 3000' amsl or 1000' agl

Clear of cloud, in sight of ground/water, with

5000m visibility

Pre-flight inspection

AIR EXERCISE:

1. Observe training area boundaries

2. Slipstream

High power - Elevator & Rudder more effective

Low power - Elevator & Rudder less effective

Ailerons unaffected by slipstream

3. Power

Increase power - Nose pitches up, yaws left

Decrease power - Nose pitches down, yaws right

4. Flaps

Lowering flaps - Nose pitches _____

Raising flaps - Nose pitches _____

Note: The change in pitch is relative to A/C type

5. Elevator trim



Holding forward - Trim forward

Holding back - Trim back

6. Rudder and aileron trim (if applicable)

7. Cabin heater, demister and fresh air vents.

HUMAN FACTORS:



Clock code - high

- level

- low

Situational Awareness -

re VFR & Training area

1'm Safe

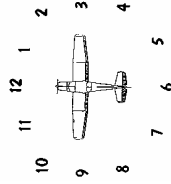

Straight-and-Level

Introduction

The primary purpose of general aviation aircraft is travel. The most efficient path of travel is a straight line.

The direct, horizontal driving distance between Christchurch and Greymouth is considerably increased by the left and right curves, as well as the ups and downs of crossing the Southern Alps. This reduces the efficiency of travel and often turns the passengers green. In addition, if your car was slipping and sliding from side to side on the straight stretches, your efficiency of travel and the comfort of your passengers would be further affected.

Leaving aside passenger comfort considerations, for efficiency, we need to be able to fly the aircraft in a straight line, on a constant heading, at a constant altitude, and without skidding from side to side.

Objectives

1. To enter straight-and-level flight from the climb and descent.
2. To fly at a constant (K) speed, at a constant altitude, in a constant direction and in balance. Revise the meaning of balance.
3. To develop a scan technique and awareness of the pilot's visual limitations.

Principles of Flight

The four forces acting on the aircraft should be explained.

Weight – acts straight down through the aircraft centre of gravity.

Lift – is produced by the wings and acts upwards through the centre of pressure.

Thrust – is provided by the engine through the propeller.

Drag – is the resistance to motion felt by all bodies within our atmosphere.

The requirements of equilibrium should be explained. Equilibrium requires a constant velocity and velocity is made up of speed and direction. Therefore, to achieve equilibrium a constant speed and direction must be maintained, and this is achieved when **lift** equals **weight** and **thrust** equals **drag**.

The arrangement of these forces to form couples should be described. Lift acts through its centre of pressure and is slightly behind (small moment arm) the C of G, and this creates a nose-down pitching couple (OHP recommended). The comparative size of lift and weight to those of the thrust and drag forces should be discussed. For general aviation aircraft the lift/drag ratio is said to be about 10:1. Ensure that your diagrams reflect this ratio **approximately**, as a picture is worth a thousand words.

The ideal arrangement for the thrust line is well below the dragline. This provides a large moment arm, which compensates for the smaller forces of thrust and drag, and it creates a nose pitch-up couple that balances the nose down couple of lift and weight. This is a desirable arrangement, as any decrease in power will pitch the nose down into a descent or glide attitude without pilot input. The arrangement of these couples is the reason for the

pitch changes demonstrated in the previous lesson as a result of increasing or decreasing power.

In practice, getting the thrust and drag lines separated far enough to balance the lift/weight couple is not possible, as you can see on your aircraft. Therefore, the manufacturer generally fits the tailplane at a **rigger's angle of incidence** that will provide a down force on the tailplane. This force is sufficient to compensate for the difference between the resultant couples of lift/weight and thrust/drag in level flight. This arrangement works primarily because of the large moment arm between the C of G and the tailplane. For the purposes of preflight briefing, rigger's angle of incidence and angle of attack can be considered as the same.

Any further imbalance between the couples as a result of weight or speed changes for example, are compensated for by the elevator.

Introduce the concept of **power plus attitude equals performance**. The desired performance in this case is a constant altitude, direction and speed for efficiency. Since lift must equal weight in level flight, and lift primarily varies with speed and angle of attack, an efficient speed or angle of attack is required. The most efficient angle of attack is approximately 4 degrees, but as no angle-of-attack indicator is fitted to light aircraft, the airspeed is used as a guide to the aircraft angle of attack. From wind tunnel tests the aircraft angle of attack can be estimated if the aircraft configuration is known. The student should be aware that configuration is more than a speed; it includes flap and power settings.

Power is easily set by reference to rpm and is set to what is recommended for normal cruise, ie, the power setting used for cross-country training. With this power set, flap up, and an attitude for about _____ kts (insert normal cruise speed), the angle of attack will be about 4 degrees, providing efficient level flight. The actual speed observed will vary on the day with variations in weight and density for example.

Common practice is to use a lower power setting than recommended cruise in the training area and circuit. This can either be explained here, in terms of fuel savings for example, or the training power setting inserted here (the angle of attack will still be about 4 degrees). Recommended cruise can then be explained in cross-country training (consult your CFI).

Aircraft Management

The use of smooth but positive throttle movements should be stressed.

Operation of the mixture control is explained¹⁰⁷, but during initial training, as a result of regular altitude and power changes, the mixture is normally left in the full rich position.

Revise why carb heat is on hot at power settings below _____ (commonly the green arc or 1900–2000 rpm).

Fuel management, including the use of the fuel pump, and monitoring techniques applicable to type should be discussed. As an example, change tanks at 30 minute intervals and calculate airborne time remaining from dipped fuel on board, at a conservative fuel flow, less reserve. Relate this to situational awareness.

The first of the three things that are totally useless to the pilot, may be mentioned here – **air in the tanks**.

¹⁰⁷ Campbell, 1994, p. 4-19

The importance of normal instrument readings is revised and SADIE checks are introduced. **S**uction, **A**mps or alternator, **D**irectional Indicator (DI), **I**ce, **E**ngine.

The requirements of VFR outside controlled airspace, below 3000 ft amsl or within 1000 ft of the ground should be revised.

Revise the lateral boundaries of the training area as applicable.

Human Factors

The effects (ADVISE mnemonic) of **V**ision and **I**nformation and **S**tress processing limitations on situational awareness are the prime considerations in this briefing.

Situational awareness should be described and encouraged through a total three-dimensional assessment of what has been, what is, and what will be. It is recommended that the aeronautical decision-making (ADM) manual be provided to the student at least by the end of this lesson¹⁰⁸.

Consistent with the objective, visual limitations are revised and emphasised. The effects of blind spots and visual illusions should be discussed¹⁰⁹.

The development of a sector scan of 20 degrees/2 seconds, the instrument scan, and head movement to minimise blind spots, are discussed.

Over-learning, to produce an automatic response in the event of an emergency, may be introduced in relation to the pre-line up takeoff brief. If the takeoff safety brief is introduced at this time (refer CFI), it need only be demonstrated during this exercise, and increasing responsibility for its completion is gradually transferred to the student before solo. A description is given in the engine failure after takeoff briefing.

Air Exercise

Power plus attitude equals performance. To enter straight-and-level from the climb, the mnemonic **APT** is used. Commonly a reference altitude at which to level out is nominated, although this can be deferred until the climbing exercise, where levelling from the climb will be revised. A reference point however, must be selected.

Attitude – with the elevator, select and hold the level attitude. The airspeed will increase only gradually, because the aircraft must overcome inertia. To assist this process climb power is maintained until a suitable airspeed has been achieved. As the airspeed increases the aircraft nose will want to pitch up, requiring subtly increasing forward pressure on the control column to maintain the correct attitude. The wings should be kept level in relation to the horizon, and rudder adjusted to keep straight on the reference point.

Power – through _____ kts, decrease power to _____ rpm. The resultant pitch change and yaw must be compensated for and they can be minimised by smooth throttle movements.

Trim – accurate trim cannot be achieved until equilibrium has been established. However, obvious control loads may be reduced immediately.

Maintaining straight-and-level involves the mnemonic **LAI**.

¹⁰⁸ Simuflight, 1996

¹⁰⁹ See Ewing (1993) or Hawkins (1993) and 'New Zealand Flight Safety', "Collision Avoidance", December, 1994

Lookout – in a scan loop, look out to the right (starboard) and scan 20 degrees for 2 seconds from right to left, passing over the nose of the aircraft.

Attitude – ensure the attitude is correct and, more importantly, constant. When the outside scan is complete scan inside for.

Instruments – instruments are used to **confirm accurate** flight, not set it. It is possible, for example, to look down and estimate height, but to know it accurately, instruments must be referred to. From left to right the instruments are scanned, and this brings the scan back to outside the starboard side of the aircraft and the process starts again.

During the instrument scan, only those instruments important to the phase of flight receive prime consideration. In this case the altimeter will probably be scanned on every sweep, with oil pressure and temperature scanned on every 10th sweep.

If a constant altitude is not being maintained, the first and easiest thing to check is the power. If the power is correct, then the attitude is incorrect – since power plus attitude equals performance.

For small altitude adjustments of less than 150 ft, the attitude is altered with elevator, and when the desired altitude is regained the correct level attitude is set and held. For bigger altitude adjustments power is usually altered. Once the instruments confirm level flight is being maintained, the aircraft can be accurately trimmed to maintain the selected **attitude**.

If a constant direction is not being maintained on the reference point (and the DI should confirm this) either the wings are not level, or the aircraft is out of balance, or both.

Balance is confirmed with the balance ball indicator. The mnemonic used to achieve balance is “stand on the ball”. If the ball is out to the left, increased pressure on the left rudder pedal is required. This is a **pressure** increase, more than a movement and “stand” implies **continued** pressure. Once the ball has been centred, reducing pressure will allow it to move out again! It should be emphasised that every time power or airspeed is altered, a change in rudder pressure will be required to maintain balance. Therefore, during those phases of flight where power or airspeed are changing, balance will need to be incorporated into the instrument scan more often. In addition, when rudder is being used to centre the ball, the wings must be held laterally level with aileron in relation to the horizon.

If the correct level attitude has been selected the airspeed will be about _____ kts. If the correct power setting is maintained the aircraft will maintain altitude, and if the wings are level and balance maintained the aircraft cannot turn. Therefore, the objective to fly at a K speed, K altitude, K direction, and balanced is achieved.

To enter straight-and-level from the descent the mnemonic **PAT** is used. Again, because of inertia, power leads the sequence to arrest the descent. Levelling at a specific altitude can be deferred to descending or incorporated here (refer CFI).

If levelling at specific altitudes is introduced here, be sure to allow for the effects of inertia. See the briefings on climbing and descending.

Power – carb heat cold (refer aircraft management), smoothly increase power to cruise power.

As airspeed increases to cruise, rpm may increase slightly, requiring another throttle adjustment. Some instructors advise setting a slightly lower power setting than cruise initially, to allow for this. Either method is acceptable.

The power change will cause the nose to yaw, if not corrected with rudder, and to pitch up. The pitch-up tendency encourages a coordinated movement because the next step is:

Attitude – with the elevator, select and hold the level attitude. Maintain wings level with aileron, and balance with rudder.

Trim – Remove obvious loads, and when straight-and-level has been confirmed through **LAI**, trim accurately to hold the correct **attitude**.

If the student quickly masters this exercise, the fact that an aeroplane will fly straight-and-level at varying airspeeds may be introduced. At this stage, instructor demonstration only is recommended.

Airborne Sequence

Demonstrate the takeoff safety brief (if applicable, refer CFI).

Configure and trim the aircraft for the normal or recommended climb that will be used in the circuit (see the briefing on climbing).

Entering straight-and-level from the climb is demonstrated and then patterned. The student is talked through the control movements to achieve straight-and-level from the climb and completes at least one practice for evaluation purposes.

You should then give the student some practice at regaining straight-and-level by disturbing the aircraft slightly in roll, pitch, trim and power. Instrument scan for accurate flight and the external sector scan technique should be demonstrated.

Leaning the mixture may be demonstrated.

Configure and trim the aircraft for the powered descent, as used in the circuit, but without flap (see the briefing on descending).

Entering straight-and-level from the descent follows the same airborne sequence as entering straight-and-level from the climb outlined above.

The lateral boundaries of the training area are revised as appropriate.

STRAIGHT-AND-LEVEL

OBJECTIVES:

1. To enter S & L from the climb and descent.
2. To fly the A/C at a constant speed in a constant direction, at a constant altitude and in balance.
3. To develop a scan technique and an awareness of the pilot's visual limits.

PRINCIPLES OF FLIGHT:

Equilibrium - constant direction, constant airspeed. **L=W T=D**

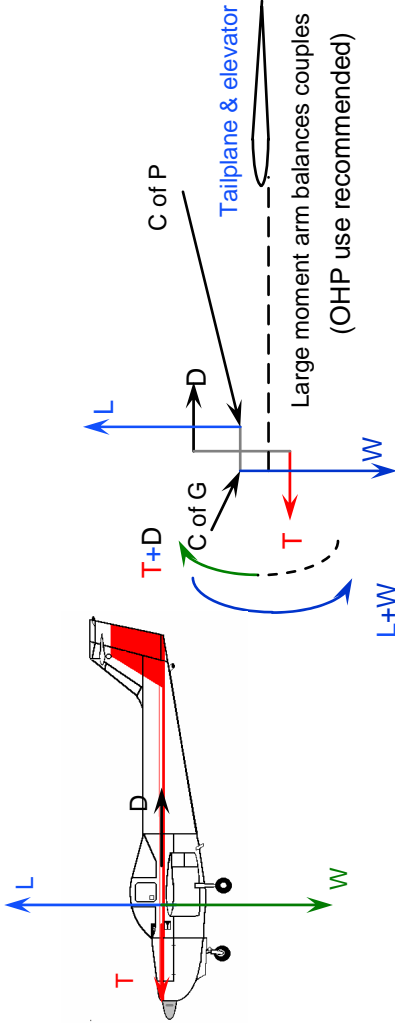

Power + Attitude = Performance

AIRCRAFT MANAGEMENT:

Throttle:- Recommended cruise rpm

Smooth, positive movements

Mixture:- Full rich for training

Carb heat :- Hot below _____ rpm

Fuel Management

Temps & pressures - normal

S.A.D.I.E.

VFR In sight of land / water

Clear of cloud with 5000 metres vis.

Orientation - local landmarks

HUMAN FACTORS:

Situational awareness

- fuel
- training area

Lookout - blindspots

- sector scan
- 2 sec per 20 degrees

I'm Safe

AIR EXERCISE:

Attain

Level - from climb

- ref point (altitude, anticipate)

A - with elevator, set & hold level attitude, maintain wings level with aileron & keep straight with rudder

P - power, thru ___kts **↓** pwr ___ rpm (balance)

T - trim to relieve c/c pressure (fwd)

Maintain

Power + Attitude = Performance

2300 rpm + As shown = **S+L at 90 kts**

- lookout scan, traffic, ref point, cloud
- attitude hold
- instruments, confirm performance
- trim as required.

Attain

Level - from descent

- ref point (altitude, anticipate)

P - Carb Ht cold, **↑** Pwr ___ rpm maintain wings level with aileron balance with rudder

A - Attitude, with elevator set & hold level attitude

T - Trim to relieve c/c pressure (fwd)

APT

S & L

climb

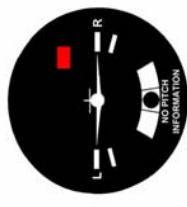

If balance ball out to one side - Stand on the Ball

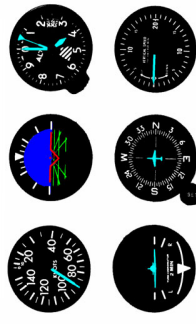

Descent

PAT

S & L

Climbing

There are primarily three types of climb: best angle, best rate, and cruise. In addition, it is common practice for an organisation to nominate a normal or recommended climb; for example, best rate 67 kts and recommended normal climb 70 kts for better vision and engine cooling. In line with the student's goal of first solo, it is recommended that the type of climb taught is that which the student will use in the normal circuit.

Some organisations teach climbing and descending as one lesson, and this has the advantage of maximising the airborne time. Other organisations prefer to teach climbing and descending as separate lessons; this has the advantage of maximising the ground time. Either method is acceptable (refer CFI) and both methods are provided in this guide. Regardless of which method is used, revision of levelling from the climb and descent is incorporated in this lesson.

Introduction

To achieve the point-to-point efficiency of the aircraft discussed in straight-and-level, the aircraft must reach its cruising level.

Objectives

1. To enter the climb from straight-and-level.
2. To climb at a constant speed and constant rate, in a constant direction and in balance.
Explain rate as feet per minute.
3. To revise straight-and-level by levelling off at specific altitudes.

Principles of Flight

To maintain a constant speed and direction the aircraft must be in equilibrium, as previously discussed. Therefore, one of the reasons for showing the student the relationships between the four forces in the climb is to show that the aircraft is in a state of equilibrium.

There is no requirement to **prove** anything in a preflight briefing. Statements illustrated with diagrams are sufficient to support the air exercise.

The forces are drawn to show that **lift is not increased** in the climb but is slightly reduced. This is a common misconception, since if lift must equal weight in level flight, it might appear logical that lift should be increased to climb.

The most important insight the student should grasp, in simple terms, is that **power controls the altitude** or that the climb performance depends on the power available. The instructor should know that climb performance depends on the excess power available over that required for straight-and-level flight at the same airspeed, but this statement is inappropriate to the student's level of instruction.

Power and thrust are considered as the same thing during briefings at this level.

The forces acting on the aircraft in the climb and the significance of their relationships are presented here in the form of a linear programmed text (see Chapter 5 programmed instruction).

The forces acting on the aircraft in a climb – a programmed text

On completion of this programmed text, you will be able to diagrammatically present the four forces acting on the aircraft in a steady climb and describe their relationships for preflight briefing purposes. As a result, your student will tell you what power setting to use for a steady climb in a low-powered modern light training aircraft.

Pre-requisites

You and the student are expected to know the relationships of the four forces for level flight.

The student is expected to have been introduced to the concept of relative airflow.

You are expected to be familiar with using a vector as a diagrammatic representation of a force and the resolving of two forces into one vector, or vice versa.

Summary

For the aircraft to be in equilibrium in the climb, constant speed and direction must be maintained. The diagram below shows the relationships of the four forces acting on the aircraft in the climb and a state of equilibrium.

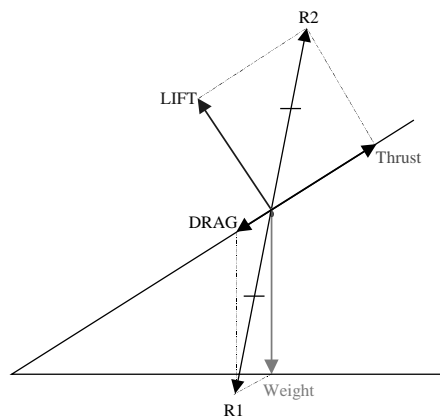

There is a resultant force down and back (**R1**) that is equal and opposite to the resultant force forward and up (**R2**).

Therefore the aircraft is in _____

The order of presentation of these forces is important to the student's understanding of how the aircraft maintains a steady climb.

Before commencing this learning session, get a pencil and some paper and find somewhere that you could reasonably expect not to be interrupted.

Draw a horizontal line to represent the earth's surface.

From the same starting point draw a sloping line to represent the aircraft climb path at about 30 to 60 degrees. Freehand drawings are acceptable.

It should be pointed out to the student that the climb angle has been exaggerated for clarity. A modern light aircraft actually climbs at an angle of approximately 3 degrees.

In straight-and-level it was shown that the four forces do not act through one point but form couples.

Explain that, for simplicity, all forces will be drawn through one point.

“For simplicity all forces will be drawn through _____”.

Draw this point as a dot about halfway up the slope on your diagram, which should now look like this:

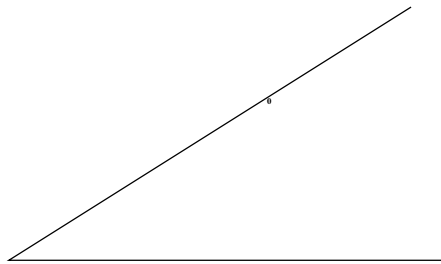

Point out that, since the aircraft is moving up the slope, the relative airflow (**RAF**) is coming down the slope. Draw and label the relative airflow.

The simplest of the four forces is weight. Weight (**W**) acts straight down toward the centre of the earth at all times. From the central point, **draw a line straight down** to represent weight. The length of this line is not important, although large diagrams are clearer. Draw **an arrowhead** on it to indicate its direction of action and label it “**W**”.

Because the aircraft is moving, there will be a resistance to forward motion. This force was explained in straight-and-level and was called _____.

From the central point, **draw a line down the slope** (approximately 1/10th the length of “**W**”) to represent drag (**D**). Draw **an arrowhead** to indicate its direction of action and label it “**D**”.

Your diagram should now look like this:

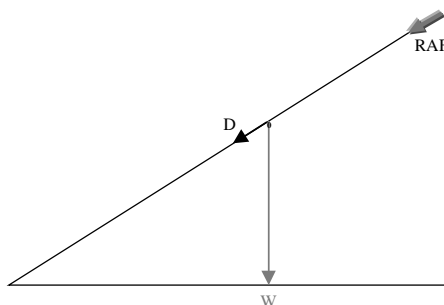

If not, redraw the diagram correctly.

If you are correct so far, **redraw the diagram anyway**, because the correct sequence is vital to getting the right answer from the student.

These two forces, weight (**W**) and drag (**D**), can be resolved into one force (through a parallelogram) acting down and back.

Draw **this resultant** on your diagram above. Draw an arrowhead and label it “**R1**”.

Your diagram should look like this:

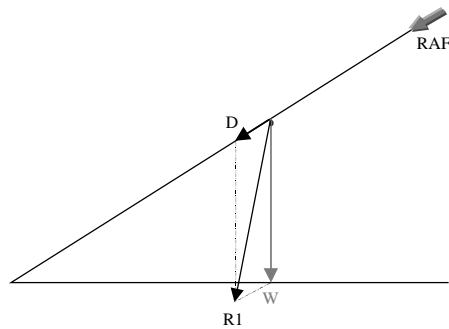

Practice drawing this again.

Then **make the statement**: “Since the aircraft **IS** in equilibrium there **MUST** be a force equal and opposite to this resultant – **R1**!”

Then, on your diagram above, draw a line from the central point, **equal and opposite** to **R1** and label this “**R2**”.

R2, the force acting forwards and up, is made up of two component forces.

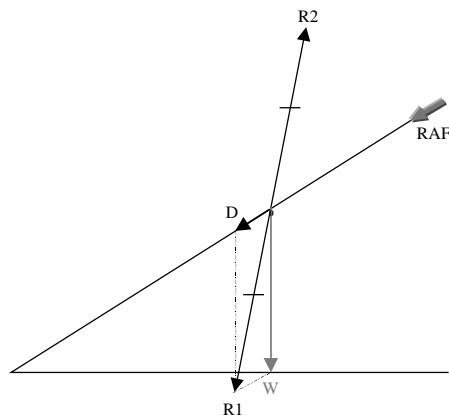

Through use of a parallelogram once again, resolve **R2** into its two components.

Lift (**L**) can be drawn from the central point at right angles to the relative airflow (**RAF**) and thrust (**T**) from the central point acting forwards, up and along the slope.

Your diagram should now show the four forces acting on the aircraft in the climb and their relationships, as well as the equilibrium.

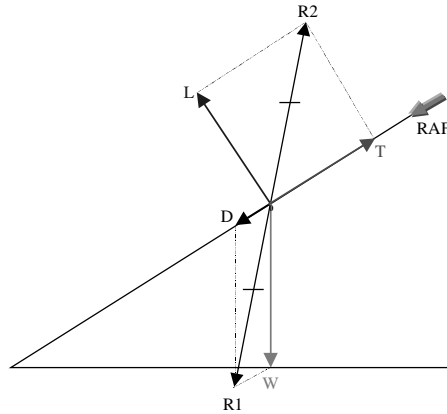

These then are the forces acting on the aircraft in a steady climb.

To reinforce the concept of relative airflow, it should be pointed out to the student that the angle of attack is still approximately 4 degrees.

The relationship of the four forces is next explained, as was done in straight-and-level.

First, thrust (**T**) and drag (**D**).

It should be clear to the student from your diagram, that **in a steady climb**, “Thrust is _____ than drag.”

Why then, does the aircraft not accelerate?

To resolve this question, break weight (**W**) down into its two components.

Draw a line downward from the central point at right angles to the slope (equal and opposite to lift) to represent the component of weight holding the aircraft (or car) on the slope. This is commonly labelled “**W1**” and;

From the arrowhead of **W1**, draw a line parallel to the slope joining **W** to represent the rearward acting component of weight and label this “**RCW**”, for rearward component of weight. (This is the component that would cause a car to run back down the hill.)

Your diagram should look like this:

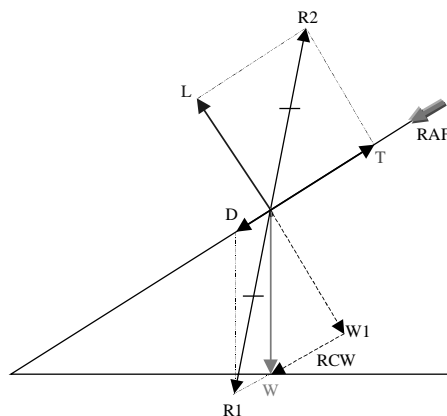

If this step caused difficulty go back, re-read the instructions and try again.

Now the rearward component of weight (**RCW**) can be added to the drag vector.

From the arrowhead of drag (**D**), draw a line down the slope the same length as **RCW** and label it.

This shows that the aircraft does not accelerate because:

Thrust is equal to the drag **plus** the _____

You may wish to finish off the parallelograms to tidy up your resolution of vectors. The end result looks like this:

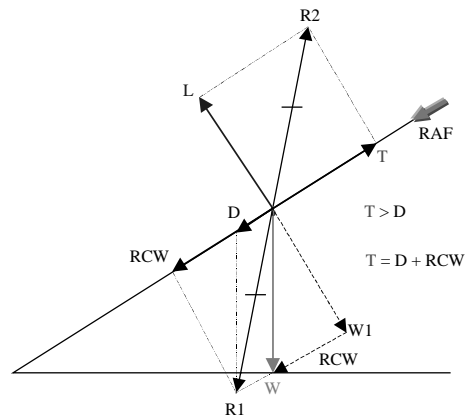

The second relationship to be explained, as for straight-and-level, is that of lift (**L**) and weight (**W**).

With the aircraft in a steady climb (equilibrium) **lift is less than weight**.

This is not easy for the student to see, so **measure** them and compare. Alternatively, since **W1** is equal to lift, **W1** can be swung across in an arc to **W**, showing that **W1**, and therefore lift, is less than weight.

Do this now to complete your diagrammatic presentation of the four forces and their relationships in a steady climb.

BUT, how can the student possibly know from this diagrammatic presentation, that the power setting for a steady climb in a modern low powered training aircraft is **full power** – without actually telling them so?

To achieve this the **significance** of lift being less than weight must be explained.

As the aircraft climbs steeper and steeper, the lift is tilted back further and further, becoming less and less, until the situation of a rocket is reached. A rocket, climbing vertically has no wings and therefore no _____! It sure can climb though!

Therefore, it can be stated, for the purpose of the preflight briefing, that: **“The climb performance depends on the power available!”**

Having made this statement, you may ask the student:

“So what power setting do you think we should use in our little training aircraft to make it climb at the best possible rate?”

Answer _____

Having discussed the forces in the climb, when climbing is given as an individual briefing, the various factors affecting the climb performance are discussed.

Power – the student has just told **you**, that the more power available the better the climb performance.

Altitude – engine performance (power) decreases with altitude, so there will be a limit to how high the aircraft can climb.

In addition, anything that opposes thrust is detrimental to climb performance.

Weight – the greater the weight, the greater will be the **RCW** (rearward component of weight). Therefore, weight reduces the rate of climb and the angle.

Flap – increases lift and drag and alters the Lift/Drag ratio. Since drag opposes thrust, **any** increase in drag will reduce the rate and angle of climb.

Wind – affects only the climb angle and the distance travelled over the ground (the range) to reach a specific altitude.

The various configurations for the three types of climb should be stated:

- Best rate of climb, full power, no flap, _____kts.
- Best angle of climb, full power, no flap, _____kts.
- Cruise climb, _____ rpm, no flap, _____kts.

The student should be informed as to which of these climbs the lesson will primarily focus on; demonstrations of the other two should be given.

If the organisation prefers a recommended climb for the normal circuit, then this is the climb that should be taught. The desired configuration should be stated and reasons given for its use.

Aircraft Management

Throttle – the student has informed you of the power setting that will give the best performance. You only need point out that not all aircraft can climb on full power continuously.

If the organisation or aircraft has a rpm limit for the prolonged climb, it should have been explained in the desired configuration above or here.

The use of full rich mixture, to aid engine cooling and prevent detonation, at power settings above 75% (below 5000 ft) should be explained or revised¹¹⁰.

Because of the detrimental effects of carb heat on engine performance, and therefore climb performance, it is not normally used at climb power settings.

It is normal to see an increase in oil and cylinder head temperatures with a decrease in oil (and fuel) pressure in the climb. The normal readings for this aircraft in the climb should be discussed. In addition, how to prevent these readings reaching their limits in an air-cooled

¹¹⁰ Campbell, 1994, p.7-13

engine should be discussed. For example, lowering the nose attitude to climb at a higher airspeed or, if necessary, levelling off for a short period.

Height limitations of the climb should be discussed, such as, service ceiling, requirement for oxygen, all airspace above 9500 ft is controlled, overlying TMAs, and upper limit of the training area.

VFR above 3000 ft amsl and more than 1000 ft agl outside controlled airspace should be introduced as five, one, one.

Human Factors

The effects (ADVISE mnemonic) of **A**ltitude and **V**ision are the prime considerations in this briefing.

The effects of trapped gases in the middle ear and sinus are discussed in relation to their expansion with increasing altitude¹¹¹. In addition, the dangers of diving and flying are discussed.

The effects of high-altitude flight on vision with regard to empty sky myopia (shortsightedness) or focal resting lengths are discussed, reinforcing the need for a clean windscreen and systematic scan technique¹¹².

Restrictions on lookout in relation to the high nose attitude are discussed. The method of lowering the nose every 500 ft, or making gentle S-turns in a prolonged climb to clear ahead of the nose, are introduced. Since one objective of this exercise is to climb in a constant direction, lowering the nose is preferred.

As a result of high power settings noise levels will be increased, and it is appropriate to discuss the effects of exposure to noise and the prevention of hearing damage¹¹³.

Situational awareness is revised in relation to aircraft positioning and VFR requirements, within the training area lateral and upper limits.

The P'M SAFE checklist may be revised, but emphasis should be placed on this checklist being completed **before** the student leaves home.

Air Exercise

The air exercise primarily consists of entering the nominated climb, and revision of straight-and-level from the climb. In addition, the various types of climb may be demonstrated, as well as the descending attitude.

A reference point, as well as an altitude to climb to, considering cloud and overlying airspace restrictions, is nominated to demonstrate or revise the effects of inertia when regaining straight-and-level at a specific altitude. Commonly, 10% of the rate of climb is used as a guide, for example, 600 ft/min – allow 60 ft. For most light training aircraft, this can be a little early, but it does have the advantage of encouraging very smooth control movements. Entry to the climb is initially taught as **PAT**¹¹⁴. This reinforces the concept that climb performance depends on power or that power controls the altitude. You should be aware that entry to the climb may be varied, depending on whether the airspeed at the time is below

¹¹¹ Ewing, 1993

¹¹² Hawkins, 1993

¹¹³ see Ewing, 1993

¹¹⁴ Campbell, 1994

or above the nominated climb speed. With airspeed at or below the nominated climb speed – power leads; with airspeed above the nominated climb speed – attitude leads (**APT**). This variation may be specifically taught during instrument flying.

But regardless of whether the speed is above or below nominated climb speed, leading with a power increase will always provide the safest outcome, so this is the only entry taught at this time.

In addition, since increasing power **smoothly** will cause the nose to pitch up, power and attitude could be considered a coordinated movement, and no engine over-speed should occur.

Power plus attitude equals performance, remains the formula for sustaining the nominated climb.

Power – check mixture rich, smoothly increase power to full power or maximum continuous; keep straight on the reference point.

Attitude – with elevator, select and hold the attitude for the nominated climb, maintaining wings level with aileron and balance with rudder.

Trim – remove excessive loads by trimming back. Once performance has been confirmed, trim accurately to maintain a constant **attitude**.

If the correct climb attitude is selected the airspeed will be _____kts (exactly). If both the attitude and the power setting are correct, the resulting performance is a steady rate of climb of _____ft/min (500–700 approx). If the wings are held level and balance maintained, the aircraft cannot turn. Therefore, the objective of entering and maintaining the climb has been achieved.

Maintaining the climb incorporates the **LAI** scan, with those instruments pertinent to the climb being scanned most frequently for accurate flight.

If the airspeed is not correct then the attitude is incorrect, and performance will be affected. **Emphasise** that the airspeed is altered by reference to attitude, and that due to inertia once a change has been made, a smaller change in the opposite direction will be required, to hold the new attitude. These corrections are commonly stated as “change – check – hold — trim”.

Attaining straight-and-level from the climb is revised, as well as the effects of airspeed and flap on climb performance.

Airborne Sequence

The standard airborne sequence, (as described in Pre-Flight Briefings), also incorporates revision of attaining straight-and-level with emphasis on a specific altitude.

Once the student has completed the basic sequence of entry to the nominated climb, the various types of climb can be demonstrated by varying the attitude to achieve the required airspeed. Observe the effect on performance and rate of climb.

With the aircraft in the nominated climb, the effect of flap can be demonstrated. While maintaining the nominated climb speed, observe the effect on performance and rate of climb.

Since a descent will be necessary at some stage, the opportunity should be taken to demonstrate the descending attitude. This should primarily concentrate on the powered descent as used in the circuit, and the subject of the next lesson. The student should be given

the opportunity to revise straight-and-level from the descent. If altitude permits, the attitude for the other types of descent may be demonstrated.

CLIMBING

OBJECTIVES:

1. To enter the climb from straight and level.
2. To climb at a constant A/S and constant rate, in a constant direction and in balance.
3. To revise S&L by levelling off at a pre-selected altitude. **L**

PRINCIPLES OF FLIGHT:

Factors affecting the climb

- Power & Altitude
- Weight ↑ - RCW ↑ ROC & angle ↓
- Flaps down - Drag ↑ ROC & angle ↓
- Wind affects angle & range only

Climb path after 1 min - ht = 500'

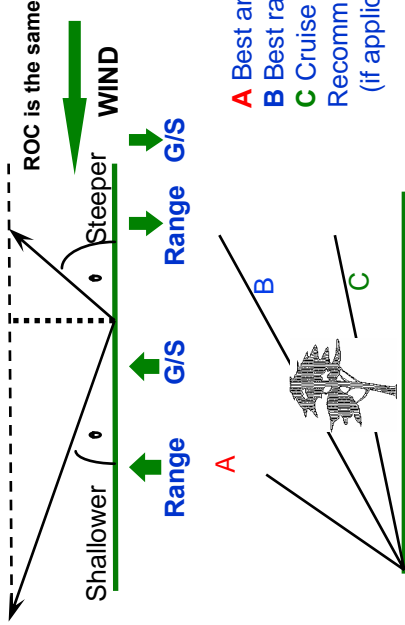

- A** Best angle - ___ kts, full power, no flap
 - B** Best rate - ___ kts, full power, no flap
 - C** Cruise - ___ kts, ___ rpm, no flap
- Recommended - ___ kts, ___ rpm, no flap (if applicable)

Climb performance depends on power available

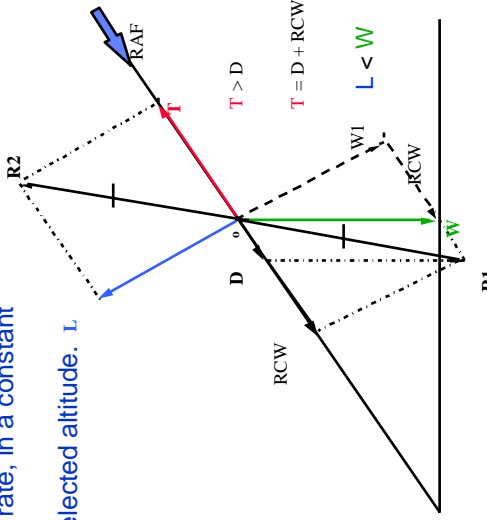

AIR EXERCISE:

Entry

Lookout, Ref Point, Ref altitude (cloud, airspace)

- Power** - mixture rich, full power, keep straight
- Attitude** - with elevator, set and hold climb attitude
- with aileron maintain wings level
- use rudder to balance (stand on ball)
- relieve control column pressure (back)

Trim

Maintaining

Power + Attitude = Performance
 ___ rpm + ___ kts = ___ ft/min (ROC)

- L** - lookout - Lower nose every 500 ft
- A** - attitude - Hold (change, check, hold, trim)
- I** - instruments - Confirm performance

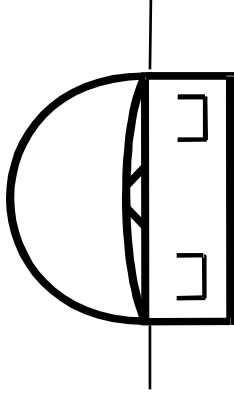
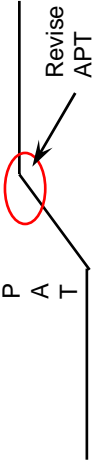

Exit

Anticipate by 10% ROC

- Attitude** - smoothly select straight & level
- Power** - through ___ kts ↓ power to ___ rpm
- Trim** - as required to relieve c/c pressure

Best rate, best angle and cruise (as applicable)

- Note: attitude and ROC

Effect of flap on climb performance

- Note: Lower nose attitude and decreased ROC

HUMAN FACTORS:

- Altitude** - sinuses, diving
- Vision** - Empty sky myopia
- Lookout** - Lower nose 500' (S turn)
- Noise** - hearing loss, protection
- Situational Awareness** - Training area - VFR

I'm Safe

AIRCRAFT MANAGEMENT:

- Throttle** - Full Power or max continuous
 - Mixture** - Rich above 75% power, cooling
 - Carb Heat** - Cold (as hot ↓ performance)
 - Temps & Press** - Normal
- (for cooling lower nose to increase A/S as req.)
- Climb restrictions:** oxygen, airspace, 5-1-1

Descending

There are primarily three types of descent: the glide descent, the powered descent and the cruise descent. In line with the student's goal of first solo, it is recommended that the type of descent taught at this time is that which the student will be expected to use in the normal circuit. Therefore, this briefing deals with the powered descent, while demonstrations of the other two types of descent are optional.

Revision of levelling from the climb and descent is also incorporated in this lesson.

Introduction

To arrive over the destination at cruise altitude is very inefficient, as some kind of spiralling descent is then required to position for landing. Therefore, the descent is generally planned well ahead and carried out at a steady rate of descent (ROD). This not only makes efficient use of the 'downhill' sector, but also is necessary for passenger and crew comfort, as the equalising of pressure changes is generally more difficult in the descent. The cruise descent is the most efficient type of descent, and this will be used during cross-country training.

The powered descent allows the aircraft to be flown at lower airspeeds than for cruise descent, while providing complete control over the rate of descent. This is useful in areas of high traffic density.

Objectives

1. To enter the descent from straight-and-level.
2. To descend at a constant airspeed and constant rate, maintaining a constant direction and balance. (Revise what rate is).
3. To revise straight-and-level by levelling off at specific altitudes.

Principles of Flight

For a steady descent, once again, equilibrium is required. Therefore, the forces acting on the aircraft in the descent are described, showing how equilibrium is achieved.

It is common practice, for simplicity, to describe the forces acting on the aircraft in a glide descent.

Start with weight, and state that for equilibrium there must be a force equal and opposite to the weight. This force **R** is made up of lift and drag. Resolve weight into its two components and show that the forward component of weight (**FCW**) acts down the slope, equal and opposite to drag. Therefore, the aircraft is in equilibrium.

Point out that the relative airflow is now coming up the slope to meet the aircraft and therefore the angle of attack is still approximately 4 degrees.

When descending is given as an individual briefing, the various factors affecting the descent are discussed.

Power – since power controls the altitude, the more power used, the less the **ROD**. Power also reduces the descent angle and increases the distance travelled over the ground, increasing the range, from a given altitude.

Weight – the greater the weight, the greater will be the **FCW**. Therefore, weight increases the airspeed and the rate of descent but does not affect the descent angle. This can be seen by increasing the length of the weight vector in your diagram. For the aircraft to remain in equilibrium there still must be a resultant **R** equal and opposite to weight. This resultant is made up of increased lift and drag as a result of the increased airspeed, which is caused by the increased forward component of weight **FCW**.

Flap – the increased drag produced by the flap will necessitate an increased **FCW** to maintain equilibrium and thereby steepen the descent, increase the **ROD**, and reduce the range.

Wind – affects only the descent angle and the range from a given altitude.

The various configurations for the three types of descent should be stated, for example:

- Glide – propeller windmilling, no flap, _____ kts.
- Powered – 1500 rpm (guide only), flap as required, _____ kts.
- Cruise – _____ rpm (within green range), no flap, _____ kts.

The student should be informed as to which of these descents the lesson will primarily focus on, with demonstrations only of the other two.

Aircraft Management

Throttle – the inefficient management of a flight, resulting in a glide descent at the destination, has been discussed in the introduction. In addition, the detrimental effects of a prolonged glide should be discussed, for example, plug fouling and excessive cylinder-head cooling. This leads to a discussion on the advantages of a powered descent.

It is common practice to use full rich mixture in the descent.

Because of the difficulty in recognising the symptoms of carburettor ice at low power settings, it is advisable to select hot air before reducing power¹¹⁵.

It is normal to see a decrease in oil and cylinder-head temperatures and an increase in oil (and fuel) pressure in the descent. The normal readings for this aircraft in the descent should be discussed. In addition, how to prevent these readings reaching their limits in an air-cooled engine in the prolonged glide **may** be discussed; for example, increasing power every 1000 ft to warm the engine oil and clear the spark plugs of carbon deposits.

It is recommended that the limitations of the descent be discussed, from minimum altitude up to the limit of the air exercise. For example, 500 ft agl minimum over unpopulated areas, 1000 ft agl minimum over built-up areas **but not less than that required to glide clear of the populated area**. Stipulate any club or organisation minimum safe height. An example might be, “No club aircraft shall be flown below 1500 ft agl unless entering or remaining in the circuit.”

VFR below 3000 ft or within 1000 ft of the ground are revised, as well as VFR above 3000 ft amsl and more than 1000 ft agl outside controlled airspace.

¹¹⁵ Campbell, 1994, p.8-13

Human Factors

The effects (ADVISE mnemonic) **A**ltitude and **V**ision are the prime considerations in this briefing.

The effect on trapped gases in the middle ear and sinuses of flying with a cold are discussed, and the dangers of diving and flying are revised. In general, a comfortable rate of descent for a fit person is 500 ft/min. In addition, the ‘valsalva manoeuvre’ is discussed and demonstrated¹¹⁶.

Situational awareness is revised in relation to VFR requirements and to aircraft positioning within the training area’s lateral and lower limits.

The effect of background on object detection is discussed, reinforcing the need for a clean windscreen and systematic scan technique¹¹⁷.

Restrictions on lookout beneath the nose are discussed, with gentle S-turns in a prolonged descent recommended to clear ahead of the nose. Since one objective of this exercise is to descend in a constant direction, the descent should not be prolonged.

The I’M SAFE checklist **may** be revised, but it should no longer require more than verbal confirmation that it was completed by the student before leaving home.

Air Exercise

In order to start this exercise, the aircraft must be levelled at a suitable altitude. Therefore, the air exercise begins with revision of climbing and levelling at specific altitudes.

The air exercise primarily consists of entering the nominated descent and revision of straight-and-level from the descent. In addition, the various types of descent **may** be demonstrated.

A reference point, as well as an altitude to descend to taking into consideration minimum heights, is nominated to demonstrate (or revise) the effects of inertia when regaining straight-and-level at a specific altitude. Commonly, 10% of the rate of descent is used as a guide to allow for inertia, for example, 500 ft/min, allow 50 ft. For most light training aircraft this is the point at which power should be smoothly increased, therefore, it is common practice to select carb heat cold at 100 ft before the nominated altitude.

Power plus Attitude equals Performance.

Entry to the descent is taught as **PAT**¹¹⁸. Once again, this reinforces that power controls the altitude.

Power – check the mixture is rich, carb heat hot, smoothly decrease power to 1500 rpm (for example), and keep straight on the reference point.

Attitude – with the power reduction the nose will want to pitch down, therefore, with elevator, hold the level attitude until the nominated descent airspeed is almost reached (allowing for inertia), and then select and hold the attitude for the nominated descent. Maintain wings level with aileron and balance with rudder.

Trim – remove excessive load by trimming _____ (usually backwards) and, once the performance has been confirmed, trim accurately to maintain a constant **attitude**.

¹¹⁶ Ewing, 1993

¹¹⁷ Hawkins, 1993

¹¹⁸ Campbell, 1994

If the correct descent attitude is selected the airspeed will be _____ kts exactly. If the attitude is correct, and the power is set correctly, the resulting performance is a steady rate of descent of _____ ft/min (approx 500). If the wings are held level and balance maintained, the aircraft cannot turn. Therefore the objective of entering and maintaining the descent has been achieved.

Maintaining the descent incorporates the **LAI** scan, with those instruments pertinent to the descent being scanned most frequently for accurate flight.

If the airspeed is not correct then the attitude is incorrect. Emphasise that the airspeed is altered by reference to attitude and that, due to inertia, once a change has been made a smaller change in the opposite direction will be required to hold the new attitude. “Change – check – hold – trim.”

Attaining straight-and-level from the descent is revised, as well as the effects of power and flap on descent performance.

Airborne Sequence

The standard airborne sequence (as described in Pre-Flight Briefings) for descending also incorporates revision of climbing and attaining straight-and-level from both the climb and descent, with emphasis on the specific altitude required.

Once the student has completed the basic sequence of entry to the nominated descent, the effect of power and flap can be demonstrated.

Maintaining the nominated descent airspeed, observe the effect on performance (rate of descent, angle of descent, and range), firstly as a result of increasing power, and secondly (once the nominated descent is restabilised) of lowering flap.

DESCENDING

OBJECTIVES:

1. To enter the descent from straight and level.
2. To descend at a constant airspeed and constant rate, in a constant direction, and in balance.
3. To level off at a pre-selected altitude.

PRINCIPLES OF FLIGHT:

Forces in a glide descent

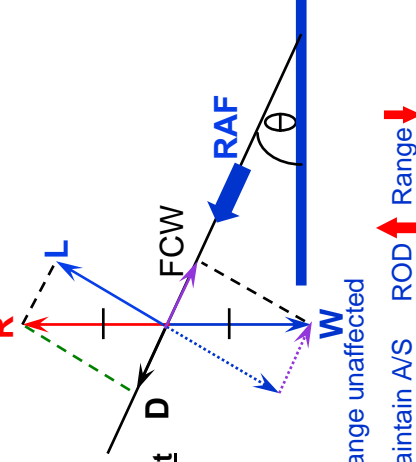

Factors affecting the descent

- Power ↑ - ROD ↓ Range ↑ Angle ↓
- Weight ↑ - FCW ↑ A/S ↑ ROD ↑ Angle/Range unaffected
- Flap down - Drag ↑ requires ↑ FCW to maintain A/S ROD ↑ Range ↓
- Wind - ROD unaffected

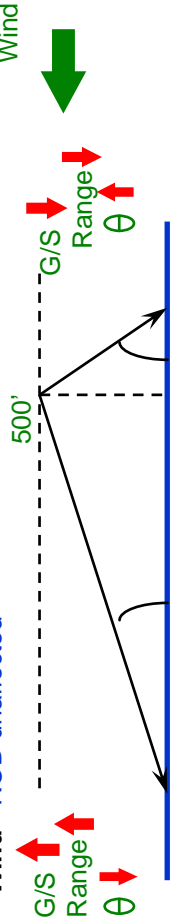

- Glide - Propeller windmilling, no flap, ___ kts.
- Powered - 1500 rpm, flap as required, ___ kts.
- Cruise - ___ rpm (within green range), no flap, ___ kts.

AIRCRAFT MANAGEMENT:

Power: Disadvantages of power off, advantages of power on
Mixture: Full rich

Carb Heat: correct use of (see air exercise)

T's & P's: Normal

Minimum Heights: not less than 500' AGL over unpopulated areas. Not less than 1000' AGL over populated area **AND** sufficient to glide clear. (Club minimum, if applicable)

HUMAN FACTORS:

Altitude - Trapped gases
 - Appropriate ROD
 - valsalva

Disorientation

- Situational Awareness (TA boundaries, VFR)

Vision

- Contrast
- Clean windshield
- Sector scan
- Gentle S turns (as req.)

I'm Safe

AIR EXERCISE:

1. Revise S & L from the climb

2. The Powered Descent

Entry - **Lookout**, Ref point, Ref altitude (not below minimums)

Power - mixture rich, Carb heat Hot, ↓ pwr to ___ rpm
 - keep straight & hold level - as A/S approaches ___ kts.

Attitude - with elevator select and hold descent attitude
 - with aileron maintain wings level
 - with rudder maintain balance

Trim - Relieve C/C pressure

Maintaining **Power + Attitude = Performance**
 ___ rpm ___ kts ___ ft/min (ROD)

Lookout - gentle S turns (prolonged descent)
Attitude - hold (change, check, hold, trim)
Instruments - confirm performance

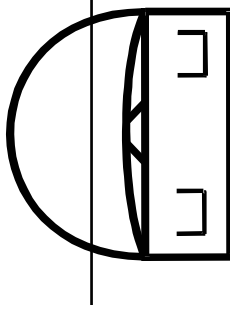

Exit - Anticipate by 100 feet, Carb Heat Cold and at 10% ROD

Power - ↑ pwr to ___ (cruise rpm, balance)

Attitude - smoothly select S & L attitude

Trim - as required to relieve C/C pressure

Effect of Power on Descent Performance

At constant A/S (70 kts) power affects ROD, angle and range

Effect of Flap on Descent Performance

At constant A/S flap affects ROD, angle and range

Climbing and Descending

When climbing and descending are given as a combined brief, there is insufficient ground-time or air-time to consider the implications of the various types of climb and descent, or all of the factors that affect performance. This approach is justifiable, as the factors affecting performance and the various types of climb and descent are dealt with over the total syllabus. Cruise climb and descent during cross-country training, best angle of climb during maximum performance takeoff, glide descent during forced landing, and so on. The combined briefing concentrates primarily on the entry and maintenance of the type of climb and descent that will be used in the normal circuit with minimal reference to factors affecting performance.

The P of F discussion sequence depends on the blackboard/whiteboard layout used. The discussion sequence given here is appropriate only to the briefing layout given at the end of this text. There are various methods of laying out the whiteboard/blackboard presentation; the example given, as with all the layouts given here, is only a guide.

Introduction

Combines the discussions, showing relevance, of both the climbing and descending briefings.

Objectives

1. To enter the climb or descent from straight-and-level flight.
2. To climb and descend at a constant speed and constant rate, in a constant direction and balanced. (Explain 'rate' as feet per minute).
3. To revise straight-and-level by levelling off at specific altitudes.

Principles of flight – Climbing

To maintain a constant speed and direction the aircraft must be in equilibrium. Therefore, the forces acting on the aircraft in both the climb and the descent are described. (Consistent with the whiteboard layout given here, forces in the climb are discussed first).

In addition, the relationships between the four forces in the climb are discussed for the various reasons given in the climbing briefing. For the presentation of the forces acting on the aircraft in the climb and the significance of their relationships, see the linear programmed text in the climbing briefing. This presentation should once again culminate in the student telling **you**, that the more power available, the better the climb performance.

The various factors affecting the climb performance are not discussed. However, the desired configuration for a climb in the normal circuit should be stated; for example, full power, no flap and 70 kts.

Aircraft Management – Climbing

Throttle – the student has informed you of the power setting that will give the best performance. You need only point out that not all aircraft can climb on full power continuously.

If the organisation or aircraft has an rpm limit for the prolonged climb, it should have been explained in the desired configuration section above – or here.

The use of full rich mixture, to aid engine cooling and prevent detonation, at power settings above 75% (below 5000 ft) should be explained or revised¹¹⁹.

Because of the detrimental effects of carburettor heat on engine performance, and therefore climb performance, it is not normally used at climb-power settings.

It is normal to see an increase in oil and cylinder-head temperatures and a decrease in oil (and fuel) pressure in the climb. The normal readings for this aircraft in the climb should be discussed. In addition, how to prevent these readings reaching their limits in an air-cooled engine should be discussed; for example, lowering the nose attitude to climb at a higher airspeed or, if necessary, levelling off for a short period.

Limitations of the climb should be discussed, it is recommended, from service ceiling down to the limit which will affect the air exercise. For example discuss, service ceiling, requirement for oxygen, all airspace above 9500 ft is controlled, overlying TMAs, and the upper limit of the training area.

VFR above 3000 ft amsl and more than 1000 ft agl outside controlled airspace should be introduced as “five – one – one”.

Human Factors – Climbing

The effects (ADVISE mnemonic) of **A**ltitude and **V**ision are the prime considerations in this briefing.

The effects of diving and flying in relation to trapped gases are discussed¹²⁰.

The effects of high altitude flight on vision with regard to empty-sky myopia or focal resting lengths are discussed, reinforcing the need for a clean windscreen and systematic scan technique¹²¹.

Restrictions on lookout in relation to the high nose attitude are discussed. The methods to clear ahead of the nose of in a prolonged climb are introduced, namely, lowering the nose every 500 ft, or making gentle S-turns. Since one objective of this exercise is to climb in a constant direction, lowering the nose is preferred.

Noise levels will be increased as a result of high power settings, and it is appropriate to discuss the effects of exposure to noise and the prevention of hearing damage¹²².

The P'M SAFE checklist **may** be revised, but emphasis should be placed on this checklist being completed **before** the student leaves home.

Air Exercise – Climbing

The air exercise consists of entering the nominated climb and revision of straight-and-level from the climb.

A reference point, as well as an altitude to climb to, considering cloud and overlying airspace restrictions, is nominated to demonstrate or revise the effects of inertia when regaining straight-and-level at a specific altitude. Commonly, 10% of the rate of climb is used as a guide to allow for inertia, for example, 600 ft/min, allow 60 ft. For most light training

¹¹⁹ Campbell, 1994, p.7-13

¹²⁰ Ewing, 1993

¹²¹ Hawkins, 1993

¹²² see Ewing, 1993

aircraft this can be a little early, but it does have the advantage of encouraging very smooth control movements. Entry to the climb is taught as **PAT**¹²³. This reinforces that climb performance depends on power, or that power controls the altitude.

Power plus Attitude equals Performance, remains the formula for entering and sustaining the nominated climb.

Power – check mixture rich; smoothly increase power to full power or max continuous; keep straight on the reference point.

Attitude – with elevator, select and hold the attitude for the nominated climb, maintaining wings level with aileron and balance with rudder.

Trim – remove excessive loads by trimming back; once performance has been confirmed, trim accurately to maintain a constant **attitude**.

If the correct climb attitude is selected the airspeed will be _____ kts (exactly). If both the attitude and the power setting are correct, the resulting performance is a steady rate of climb at _____ ft/min (500–700 approx). If the wings are held level and balance maintained, the aircraft cannot turn. Therefore, the objective of entering and maintaining the climb has been achieved.

Maintaining the climb incorporates the **LAI** scan, with those instruments pertinent to the climb being scanned most frequently for accurate flight.

Attaining straight-and-level from the climb is revised.

Principles of Flight – Descending

Having discussed the climb, the forces in the glide descent may be discussed. Only the effects of power and flap on rate of descent (ROD) are discussed, because those items are most pertinent to the circuit.

Power – since power controls the altitude, the more power used, the less the ROD.

Flap – the increased drag produced by the flap will necessitate an increased FCW to maintain equilibrium and thereby steepen the descent, increasing the ROD.

The desired configuration for a descent in the normal circuit should be stated; for example, 1500 rpm and flap _____ will give an appropriate rate of descent in the _____ (aircraft type).

Aircraft Management – Descending

It is common practice to use full rich mixture in the descent.

Because of the difficulty in recognising the symptoms of carburettor ice at low power settings, it is advisable to select hot air before reducing power¹²⁴.

It is normal to see a decrease in oil and cylinder-head temperatures and an increase in oil (and fuel) pressure in the descent. The normal readings for this aircraft in the descent should be discussed.

¹²³ Campbell, 1994

¹²⁴ Campbell, 1994, p.8-13

It is recommended that the limitations of the descent be discussed, from minimum altitude up to the limit that will affect the air exercise. For example, 500 ft agl minimum over unpopulated areas, 1000 ft agl minimum over built-up areas, **but not less than that required to glide clear of the populated area.** Stipulate any club or organisation minimum safe altitude. An example might be, “No club aircraft shall be flown below 1500 ft agl unless entering or remaining in the circuit.” VFR below 3000 ft amsl or within 1000 ft of the ground is revised.

Human Factors – Descending

The effects (ADVISE mnemonic) of **A**ltitude and **V**ision are the prime considerations in this briefing.

The effects on trapped gases in the middle ear and sinuses of flying with a cold are discussed, and the ‘valsalva manoeuvre’ is demonstrated.

Situational awareness is revised in relation to VFR requirements, and to aircraft positioning within the training area lateral and upper limits.

The effect of background on object detection is discussed, reinforcing the need for a clean windscreen and systematic scan technique¹²⁵.

Restrictions on lookout beneath the nose are discussed, with gentle S-turns in a prolonged descent recommended to clear ahead of the nose. Since one objective of this exercise is to descend in a constant direction, the descent should not be prolonged.

Air Exercise – Descending

The air exercise consists of entering the nominated descent and revision of straight-and-level from the descent.

A reference point, as well as an altitude to descend to taking into consideration minimum heights, is nominated to demonstrate (or revise) the effects of inertia when regaining straight-and-level at a specific altitude. Commonly, 10% of the rate of descent is used as a guide to allow for inertia, for example, 500 ft/min, allow 50 ft. For most light training aircraft this is the point at which power should be smoothly increased, therefore, it is common practice to select carb heat cold at 100 ft before the nominated altitude.

Power plus Attitude equals Performance.

Entry to the descent is taught as **PAT**. Once again this reinforces that power controls the height.

Power – check the mixture is rich, carb heat hot, smoothly decrease power to 1500 rpm (for example), and keep straight on the reference point.

Attitude – with the power reduction the nose will want to pitch down, therefore, with elevator, hold the level attitude until the nominated descent airspeed is almost reached (allowing for inertia), and then select and hold the attitude for the nominated descent. Maintain wings level with aileron and balance with rudder.

Trim – remove excessive load by trimming _____ (usually backwards) and once the performance has been confirmed, trim accurately to maintain a constant **attitude**.

¹²⁵ Hawkins, 1993

If the correct descent attitude is selected the airspeed will be _____ kts exactly. If the attitude is correct, and the power is set correctly, the resulting performance is a steady rate of descent of _____ ft/min (approx 500). If the wings are held level and balance maintained, the aircraft cannot turn. Therefore the objective of entering and maintaining the descent has been achieved.

Maintaining the descent incorporates the **LAI** scan, with those instruments pertinent to the descent being scanned most frequently for accurate flight.

Attaining straight-and-level from the descent is revised, as well as the effects of power and flap on descent performance.

Airborne Sequence

The standard airborne sequence (as described in Pre-Flight Briefings) incorporates revision of attaining straight-and-level from both the climb and descent, with emphasis on the specific altitude required.

Once the student has completed the basic sequence of entering and maintaining the nominated climb, entering and maintaining the powered descent is taught.

Once the student has completed the sequence of entering and maintaining the descent, the effect of power and flap on rate of descent can be demonstrated.

CLIMBING AND DESCENDING

OBJECTIVES:

1. To enter the climb and descent from straight and level.
2. To climb and descend at a constant A/S and constant rate, in a constant direction and in balance.
3. To revise S&L by levelling off at a pre-selected altitude.

PRINCIPLES OF FLIGHT:

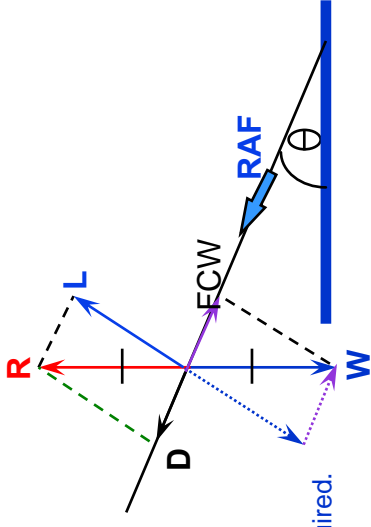

Climb performance depends on power available

Recommended or normal climb _____ rpm, _____ kts, no flap

Powered descent _____ rpm _____ kts, flap as required.

AIRCRAFT MANAGEMENT:

Full Power or max continuous

Mixture - Rich above 75% power. Carb Heat - Off

Temps & Press Normal (for cooling lower nose to increase A/S as req.)

Climb restrictions: oxygen, airspace (TA if applicable), 5-1-1

Mixture: Full rich **Carb Heat:** Prior to descent rpm below _____

T's & P's Normal

Minimum Heights: 500' AGL or 1000' AGL over pop. area.

VFR: below 3000' AMSL or within 1000' AGL

HUMAN FACTORS:

Altitude - diving. Vision - Empty sky myopia,

Lookout - Lower nose 500'. Noise - protection.

I'm Safe (prior to leaving home)

Altitude: - Trapped gases, 'valsalva'

Disorientation: - Situational Awareness (TA boundaries, VFR)

Vision: - Contrast, Clean windscreen, Sectorised scan (S-turns as required)

AIR EXERCISE:

Entry Lookout, Ref Point, Ref altitude (cloud, airspace)

Power - mixture rich, full power, keep straight

Attitude - with elevator, set and hold climb attitude

- with aileron maintain wings level

- use rudder to balance (stand on ball)

- relieve control column pressure (back)

Maintaining Lookout - Lower nose every 500 ft

Attitude - Hold (change, check, hold, trim)

Instruments - Confirm performance

Entry - **Lookout**, Ref point, Ref altitude (not below minimums)

Power - mixture rich, Carb heat Hot, **pwr** to _____ rpm
- keep straight & hold level - as A/S approaches _____ kts.

Attitude - with elevator select and hold descent attitude

- with aileron maintain wings level

- with rudder maintain balance

Trim - Relieve C/C pressure

Maintaining Lookout

Attitude - Hold (change, check, hold, trim)

Instruments - Confirm performance

$$\text{Power} + \text{Attitude} = \text{Performance}$$

$$\text{_____ rpm} + \text{_____ kts} = \text{_____ ft/min}$$

Medium Turns

For the purposes of the pre-flight briefing, a medium turn is defined as a turn of up to 30 degrees angle of bank. The reasons for this will be explained more fully in the steep turns briefing.

Common practice is to teach the 30 degree angle of bank turn, and this, combined with the rate one turn taught during compass turns, is sufficiently representative of medium turns to satisfy the requirements of the flying training syllabus.

Climbing and descending turns have been incorporated within this briefing as **one** method of presenting the material. Some organisations prefer to present a separate briefing on climbing and descending turns (refer CFI), and this practice is **not** discouraged (see Section 2 introduction).

Introduction

Define the medium turn and explain angle of bank. Explain that, logically, if you wanted to change direction you would not normally complete an entire circle. However, not only do we want to learn how to change direction, we want to improve situational awareness by regaining straight-and-level on the original reference point. We also want to practice smooth control inputs by allowing for the aircraft inertia.

Objectives

1. To change direction through 360 degrees at a constant rate – using 30 degrees angle of bank – while maintaining a constant altitude and balance. (Explain ‘rate’ as degrees/minute or second.)
2. To enter a medium turn during the climb and the descent.

Principles of Flight

To explain how the aircraft turns, the situation of lift equal to weight in straight-and-level flight is first drawn on a diagram of the aircraft flying into the board.

Wherever possible, diagrams show the aircraft flying into the board so that the student is orientated (see Chapter 7 guidelines for the use of instructional aids).

Lift Vector

When the aircraft is banked the lift vector is inclined. Breaking lift down into its two components shows that the horizontal component of lift provides a force (actually an acceleration) toward the centre of the turn, and that this is what turns the aircraft. It is similar to turning on a bicycle. For many students this can produce a tendency to physically lean out of the turn. The student should be informed that this is a natural human factor tendency, as the body tries to realign itself with the perceived vertical, and this is overcome through exposure and practice. In addition, the student may feel a slight increase in their weight as an opposite reaction to the acceleration (force) toward the centre of the turn.

The vertical component of lift no longer supports the aircraft weight.

For the aircraft to maintain a constant altitude or height, the vertical component of lift must equal the weight, and this is achieved by increasing the lift.

Of the options available to the pilot for increasing lift, changing the angle of attack is the most practical. It is not practical, for example, to go faster in the (level) turn than straight-and-level, or to change the wing shape.

An increase in lift, through whatever means, will always produce an increase in drag. Therefore, there will be a reduction in airspeed.

In the medium level turn, the lift and drag increase is so slight that the decrease in airspeed is insignificant and may be ignored.

Adverse Yaw

Adverse yaw as a result of aileron drag is discussed next. To produce the roll that banks the aircraft, the ailerons are used. The down-going aileron changes the wing shape and increases the angle of attack, increasing lift on that wing. At the same time on the other wing, the aileron moves up, changes the shape, and decreases the angle of attack, thus decreasing lift.

For any increase in lift there will be an increase in drag, thus on the up-going wing there will be an increase in drag; conversely, on the down-going wing there will be a decrease in drag. If uncorrected these changes will tend to yaw the nose of the aircraft away from the direction of the turn.

This undesirable effect is countered with rudder, which is applied in the direction of roll or turn to prevent adverse yaw and maintain balance.

The instructor should be aware that early aileron design produced considerable profile drag, because the down-going aileron significantly increased the frontal area in comparison to the up-going aileron. Both differential and frise ailerons were introduced to address this problem, by reducing the difference in drag produced on each wing. Even so, adverse yaw was not eliminated. This is because the basic requirement to increase lift on one wing to produce the roll – by changing shape and angle of attack, and therefore C_L – increases the induced drag.

For the purposes of the pre-flight briefing, however, the types of drag that produce the adverse yaw are not relevant. The statement that an increase in lift will produce an increase in drag is sufficient.

Rudder to counteract adverse yaw will be required only while the ailerons are actually being deflected. Therefore, once the desired angle of bank has been achieved, the rudder is once again neutralised. In addition, the amount of rudder required to overcome the adverse yaw is dependent on the rate and degree of aileron deflection. During a rapid roll more rudder will be needed than at slower roll rates. At this level, the amount of rudder required is kept to a minimum by encouraging smooth control inputs. At low airspeeds the ailerons will need to be deflected further to achieve the same roll rate as at higher speeds. This will significantly increase the induced drag and require more rudder to negate the adverse yaw. This may become apparent during the descending turns.

Overbanking

Overbanking is a tendency for the aircraft to want to roll into the turn or increase the bank angle of its own accord.

In a flat turn, it can be shown that the outside wingtip travels further and therefore faster than the inside wingtip. The increase in airspeed of the outer wing results in an increase in lift, which produces a tendency to roll into the turn. Given the wingspan of the average light aircraft, this effect is minimal. It will be reduced as the angle of bank is increased, because the difference in the distance travelled between each wing will reduce – at 90 degrees angle

of bank there is no difference. In the medium level turn, however, there will be a tendency for the aircraft to increase its angle of bank if uncorrected.

The tendency to roll into the turn is more pronounced during a climbing turn because, in addition to the above, the outer wing meets the relative airflow at a higher angle of attack than the inner wing.

In the descending turn, the angle of attack on the inner wing is increased and this may negate the tendency to roll into the turn – or even decrease the angle of bank. The causes of these tendencies may be explained in the climbing and descending turn briefing should you or your organisation wish to brief these separately.

For the purposes of this briefing the increased tendency to overbank in the climbing turn and the decreased tendency in the descending turn can simply be stated, and the emphasis placed on negating these tendencies by maintaining the required angle of bank with aileron, commonly referred to as **holding off**.

The effect of increased drag on climb performance is revised in relation to the increased drag produced as a result of turning. Therefore, where a requirement to turn **and** climb exists, the angle of bank is commonly limited to a maximum of 20 degrees, to minimise the detrimental effects of increased drag on climb performance. In addition, to maintain a constant airspeed in both the climbing and descending turn, the tendency to increase backpressure will need to be suppressed.

There are no significantly detrimental effects on performance when descending at angles of bank of up to 30 degrees.

Aircraft Management

As there are no new engine handling considerations directly affecting this exercise, revise **SADIE** checks and the minimum and maximum altitudes to be used in relation to training area boundaries and, if applicable, the current weather.

Discuss situational awareness in relation to countering the effect of wind to remain within the lateral boundaries of the training area.

Introduce or revise the pre-flight passenger safety brief, taxi instrument checks, and the takeoff safety brief.

Introduce VFR requirements within controlled airspace (5 –1 –1).

Human Factors

The effects (ADVISE mnemonic) of **D**isorientation, **V**ision and **S**tress are the prime considerations of this briefing.

Disorientation is discussed in relation to situational awareness and is minimised by completing the turn through 360 degrees, rolling out on the same reference point as that chosen before starting the turn. For this reason, it is advisable to choose an easily identifiable reference point.

Situational awareness is further promoted by the introduction or revision of **lookout – listen out**.

The limitations of a visual scan and the time required to complete a thorough lookout are revised. The technique of looking in the opposite direction to the turn, starting at the tail and

moving forward through the nose of the aircraft and into the direction of the turn, so as to minimise possible conflict with aircraft directly behind, is discussed. In addition, the restrictions imposed by the airframe are revised.

For some students the sensations of the turn may be uncomfortable at first. This will have the effect of raising stress levels and result in decreased performance. The student should be informed that any discomfort will generally be overcome with exposure and practice.

Air Exercise

The air exercise discusses entering, maintaining and exiting the medium level turn, at a bank angle of 30 degrees.

Entry – a reference altitude and prominent reference point are chosen and the lookout completed.

The aircraft is rolled smoothly into the turn with aileron, and balance maintained by applying rudder in the same direction as aileron to overcome adverse yaw. At the same time backpressure is increased on the control column to maintain the altitude. It should be emphasised that the increase in backpressure is very slight. For example, if the aircraft was being flown with the finger and thumb in level flight, one more finger would be required to maintain the turn.

At 30 degrees angle of bank – which is recognised through attitude and confirmed through instruments – a slight check of aileron will be required to overcome inertia in roll, and rudder pressure reduced to maintain balance.

The various markings of the artificial horizon should be explained, up to the 30-degree bank angle at least.

Maintaining the turn incorporates the **LAI** scan. Lookout into the turn is emphasised, and the attitude for 30 degrees angle of bank and level flight is maintained. The correct angle of bank is maintained with aileron and altitude with backpressure.

During any manoeuvre, only those instruments pertinent to the manoeuvre are scanned, and trim is not used.

Exit – look into the turn for traffic and for the reference point. Allow for inertia by anticipating the roll out so that the wings will be level when the reference point is regained. Common practice is to use half the bank angle as a guide to anticipation, for example, 30 degrees bank, start the roll out 15 degrees before the reference point. This encourages a smooth roll out, which is easier to coordinate.

Approximately 15 degrees before the reference point is reached, start to smoothly roll wings level with aileron, balance with rudder in the same direction to overcome adverse yaw, and relax the backpressure to re-select the level attitude and maintain constant altitude.

The climbing and descending turn **may** be dealt with under the “Considerations” heading.

In both climbing and descending turns, the attitude must be adjusted to maintain the nominated airspeed. This requires that backpressure is not increased but is maintained or slightly decreased.

The climbing turn is commonly demonstrated at 15 degrees angle of bank – or rate one.

Airborne Sequence

The student should be capable (with regard to the training area boundaries and cloud) of climbing to a suitable altitude and levelling off.

Entry to, maintaining and exiting the medium level turn follows the standard airborne sequence. However, rather than patter the entry as “roll in with aileron, balance with rudder”, it may be more beneficial to the student to patter the actual control movements being made; for example, in a turn to the right, “roll in with right aileron, balance with right rudder”.

Aileron Drag

The adverse yaw produced by the use of aileron is difficult for the student to observe in a modern light aircraft. As aileron drag is primarily caused by induced drag, which is greatest at high angles of attack, a demonstration at low speed may permit the student to observe this undesirable effect. The decision to include a demonstration of aileron drag in the air exercise will depend on the aircraft type and the CFI.

In maintaining the required angle of bank, the tendency for the aircraft to overbank **may** become apparent, in that the ailerons may not be neutral but slightly **held off**.

Any tendency by the student to lean out of the turn should be discouraged by encouraging the student to relax.

You should emphasise the lookout before and during the turn by, for example, leaning past the student to see into the turn.

Once the student has completed a satisfactory medium level turn, both left and right, from straight-and-level, the student enters a climb or descent and the medium climbing turn (15 degree, for example) or 30 degree descending turn attitudes are demonstrated.

It is recommended that this lesson be followed by a period of revision before introducing the basic stall (refer CFI). This exercise is commonly carried out by your supervisor to ensure that the student has learnt the basics.

The recommended revision exercise incorporates:

- Entering the medium turn from the climb and descent (as above).
- Entering level flight from the climb and descent while maintaining the medium turn.
- Entering the climb or descent from a level medium turn.

Alternatively, these exercises **may** be incorporated within the climbing and descending turn briefing, should the organisation choose to separate climbing and descending turns from the medium turns brief (refer CFI).

MEDIUM TURNS

OBJECTIVES:

1. To turn the aircraft through 360 degrees at a constant rate at 30 degrees angle of bank while maintaining constant altitude and in balance.
2. To enter a medium turn from the climb and the descent.

PRINCIPLES OF FLIGHT:

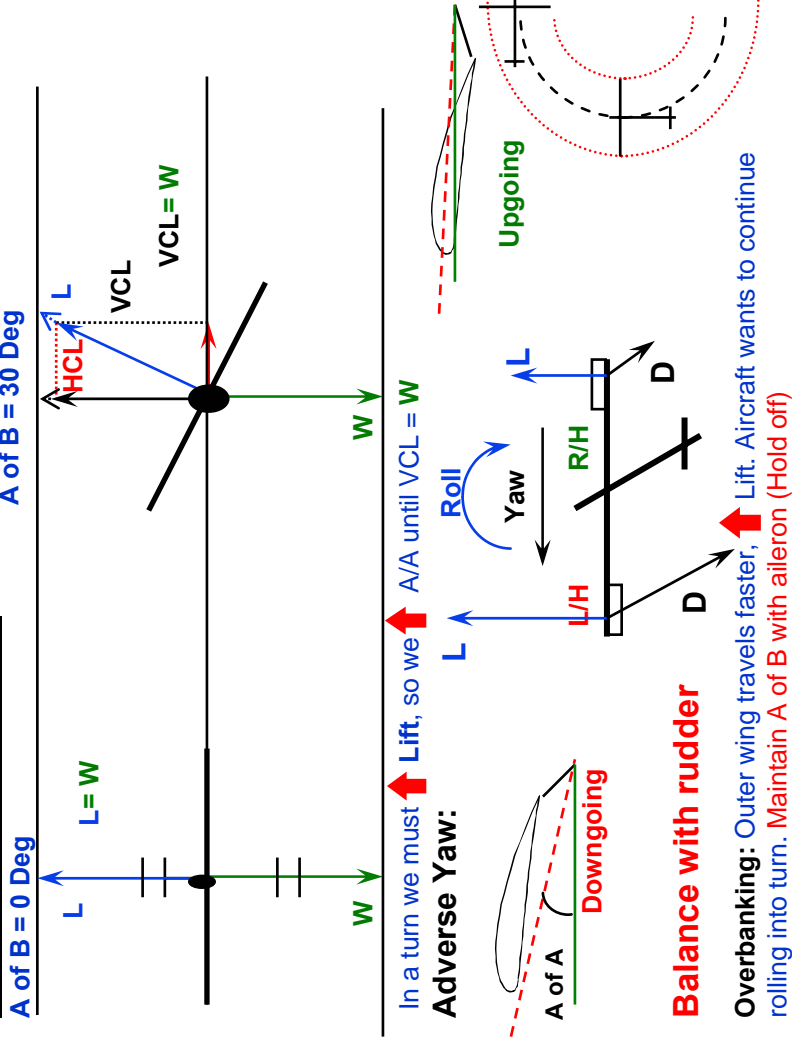

AIRCRAFT MANAGEMENT:

- SADIE**
 TA boundaries - vertical & lateral - drift
 Pax. Safety brief
 Taxi - instrument checks
 Takeoff brief
 VFR - controlled airspace **5-1-1**

HUMAN FACTORS:

- Disorientation** - Large ref.point.
Situational Awareness - look, listen
Vision - **Lookout** prior and during
 Clear opposite, ahead and into turn.
Stress - discomfort - resisting bank

AIR EXERCISE:

Demonstrate: Adverse yaw (refer CFI)

Medium Level Turns:

- Entry**
- Ref Alt, Ref point, **Lookout**
 - Roll in with **Aileron** (smoothly)
 - Balance with **Rudder**
 - Set Attitude with **Elevator** (↑BP)
 - 'Check' at 30 degree A of B
- Coordinate**

- Maintain**
- **Lookout**
 - **Attitude**
 - **Instruments**

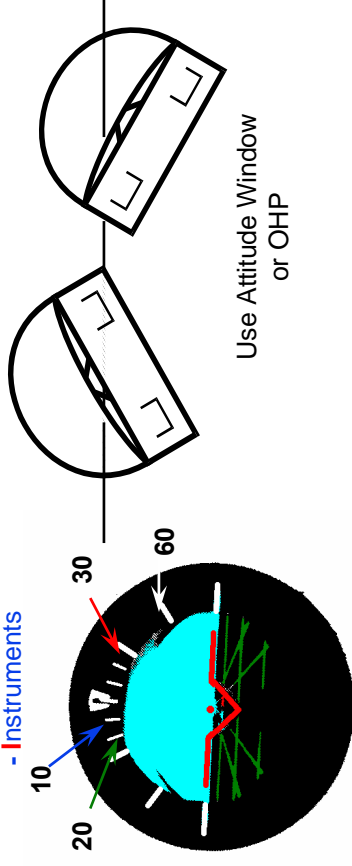

- Exit:**
- Anticipate Ref point by 1/2 bank angle
 - Roll out with **Aileron** (smoothly)
 - Balance with **Rudder**
 - BP with **Elevator**
- Coordinate**

Considerations:

- Climbing turn** - maintain attitude for ___ kts
 - limit bank angle to 20 degrees max.
 - tendency to overbank

- Descending turn** - maintain attitude for ___ kts
 - tendency to underbank

Basic Stalling

Many students approach stalling with apprehension. It is vital that you minimise the student's stress if the objective of the exercise is to be achieved. Many new terms and concepts will be introduced to the student during this briefing, and these should be kept in as simple terms as possible.

Introduction

When an aircraft stalls, the engine does not stop. The stall is a breakdown of the smooth airflow over the wing into a turbulent one, resulting in a decrease in lift. The lift will no longer fully support the aircraft weight, and the aircraft **sinks**.

When an aircraft stalls altitude will be lost.

By **basic** stall we mean, keeping the aircraft configuration as simple as possible. Usually, power will be at idle (**not** off), flap will be up, and if the undercarriage could be raised it would be.

There are two reasons why the student needs to know about stalling. The first is **to avoid the inadvertent stall**. The stall does not just happen. There are many warning signs of its approach, and to ignore these – other than under carefully controlled conditions – indicates either poor situational awareness or a hazardous mental attitude on behalf of the pilot.

For a full description of hazardous mental attitudes and how these can be overcome through instruction, refer to 'Aeronautical Decision-making'¹²⁶.

If you were learning, for example, to drive with a professional school, you would be taught what the symptoms of an approaching skid were, you'd enter a skid to experience it and you'd learn how to recover from the skid. This would all be done under **carefully controlled conditions** providing a maximum level of safety to you and others.

The purpose of this exercise would be to improve your awareness of what brings about the skid and how to avoid it. Other than carefully controlled practice, to ensure you stayed current on your skid recognition and recovery technique, you'd spend the rest of your life preventing the skid.

So that a pilot can spend the rest of their life preventing the **inadvertent** stall, they need to be able to recognise the symptoms of an approaching stall, experience it, and learn the correct recovery technique.

The second reason for being familiar with the stall is that every landing is a **controlled** approach to the stall.

Objectives

1. To improve situational awareness by learning to recognise the symptoms of the approaching stall, experience the stall itself, and recover with the minimum altitude loss.

Explain that the altitude loss will not be greater than 300 ft by the time you've done all that, and that with practice the altitude loss will be reduced to about 50 ft. In addition, because this exercise is carried out under safe and carefully controlled conditions, the aircraft will not be anywhere near the ground during the exercise.

¹²⁶ Simuflight, 1995

2. Through situational awareness, prevent the inadvertent stall from occurring.

Principles of Flight

The cause of this breakdown of smooth airflow is the result of presenting the wing to the airflow at too high an angle of attack.

The model aircraft may be used to show that aircraft do not fly at an angle of attack of 90 degrees to the relative airflow. Therefore, somewhere between straight-and-level and 90 degrees, a limit is reached at which the air can no longer flow smoothly over the aerofoil.

For the average all-purpose aerofoil used in general aviation, this limit is reached at an angle of attack of **about** 15 degrees. It should be emphasised that no matter what speed the aircraft is flying at, when this angle is exceeded the aircraft will stall because of the break down of the smooth airflow.

To reach this limit the aircraft must be mishandled. One way to do this would be, from straight-and-level, to close the throttle to idle and attempt to continue flying level.

In straight-and-level flight the angle of attack was **about** 4 degrees and the airspeed about ___ kts.

Since lift is primarily controlled through angle of attack and airspeed, and lift must equal the aircraft weight to maintain level flight, then, as the airspeed decreases, the angle of attack must be increased to maintain lift equal to weight.

As the angle of attack increases, the airflow finds it more and more difficult to follow the contour of the aerofoil smoothly, and the point at which the airflow breaks away from the aerofoil, the separation point, moves forward from the trailing edge. At the same time, the point through which lift acts, the centre of pressure (C of P), also moves forward along the chord line; this movement is unstable.

Eventually, the stalling (or critical) angle of attack is reached, and the inability of the air to flow smoothly over the top surface of the aerofoil results in a decrease in lift and a large increase in drag. This may be illustrated by the C_L against angle of attack graph (OHP recommended). The result is that the aircraft sinks and altitude is lost. At the same time, the C of P moves rapidly rearward; this movement is stable. The increased moment produced by this rearward movement of the lift vector causes the aircraft nose to pitch down.

The factors affecting the stalling speed are discussed in the advanced stalling briefing, as the emphasis of this briefing is on the cause of the stall - exceeding the critical angle.

Aircraft Management

Through good management this situation can be avoided. For the purposes of this exercise, however, aircraft management concentrates on ensuring a completely safe environment in which to practice stalling.

To ensure that the conditions are carefully controlled, before the first stall, the HASELL checklist is introduced.

H – Height (not altitude) must be sufficient to recover by not less than 2500 ft above ground level.

Reassure the student that the maximum altitude loss will be approximately 300 ft and that the minimum height to recover by (2500 ft agl) is used to ensure a perfectly safe environment in which to practice.

Some organisations stipulate recovery by a height higher than 2500 ft agl. This practice is neither encouraged nor discouraged. Sufficient to recover by 2500 ft is the **minimum**, and any requirement to recover at a greater height can be seen as a requirement for a higher level of good aviation practice on the part of that organisation. The only disadvantage of stipulating a greater height **may** be weather or airspace restrictions.

What you **must not do** is say one thing and do another, for example, recovering by 3000 ft amsl rather than 3000 ft agl.

A – Airframe. The entry configuration is revised: idle power, no flap, and the suitability of the aircraft to complete the manoeuvre.

The HASELL checklist is a pre-aerobatic checklist that has been adapted for stalling, a non-aerobatic manoeuvre. **Airframe** is more appropriate to aerobatics than stalling in the context of, “Is the aircraft approved to carry out the manoeuvre?” Common practice is to simply state the configuration that will be used during the entry to the stall.

S – Security. No loose articles, harness secure.

Point out that to have loose articles in the cockpit is not desirable at **any** time and explain why, for example, jammed controls. Explain that harness security is a good aviation practice consideration. The basic stall in the modern light aircraft is very gentle, but it is good aviation practice that a check of harness security is made.

E – Engine. Temperatures and pressures normal, mixture rich, fuel sufficient and on fullest tank, and commonly the electric fuel pump is switched on to guard against airlock (refer CFI). In addition the carb heat **may** be cycled to ensure no ice has formed.

This is a routine systems scan to ensure everything is normal, before and during the exercise. Mixture rich, fullest tank and fuel pump on, are part of aircraft management to ensure the safest possible environment.

L – Location. Not over a populated area and clear of known traffic areas, including airfields.

Reassure the student that stalling is not carried out over populated areas because large power changes will be made throughout the exercise. The change in volume of engine noise may disturb people on the ground, and they might think something is wrong with the aircraft, and possibly even call the police.

As the aircraft will purposely be mishandled and altitude will be lost, for our own safety and the safety of others this exercise is not carried out near other aircraft.

L – Lookout. Carry out a **minimum** of one 180-degree clearing turn, or two 90-degree clearing turns, to ensure other traffic will not result in conflict.

Some organisations require a minimum of one 360-degree clearing turn. Turning 180 degrees is a minimum, and any increase on this is good aviation practice.

To improve situational awareness, during the last part of the turn, start looking for a suitable reference point on which to roll out and use for the stall entry.

The HELL checks (a subset of HASELL) are carried out between each subsequent stall with **Lookout** requiring a **minimum** of a 90-degree turn. Common practice is to make all these turns in the one direction (usually left) so that the exercise is carried out in a box over the same ground features. This **general** rule should be tempered with the requirements of situational awareness in regard to wind direction and strength (drift), the training area boundaries, and other traffic.

As large power changes will be made, it is appropriate to revise the requirement for smooth but positive throttle movements and for the use of carb heat.

The pre-flight inspection should include a search for loose articles, and, as the aircraft will be purposely mishandled, it is considered poor aviation practice to carry out this exercise with passengers on board.

Human Factors

With regard to situational awareness considerations **D**isorientation and **S**tress (ADVISE mnemonic) are the prime considerations of this briefing.

Situational awareness considers not only the position of the aircraft three dimensionally within the training area but also the warning symptoms of the approaching stall, and awareness of the aircraft flight phase – power idle but attempting to maintain level flight.

The effects of stress are reduced through overlearning, so as to produce an initial automatic response, and experiencing sensations of the stall, so as to desensitise the pilot. The student should be advised that physical discomfort is not common, but it is possible, and any discomfort during the exercise should be voiced so that the aircraft can be flown level until comfort is restored.

Discreetly ensure a sick bag is available.

Air Exercise

Entry

HASELL checks are completed and a reference point confirmed by the DI on which to keep straight is nominated.

Nominating a reference altitude is a function of the HASELL/HELL checks.

Because of the high nose attitude at the stall, either choose a high reference point or have the student sight one along the side of the engine cowling.

From level flight, carb heat is selected hot and the throttle closed smoothly. As the nose will want to yaw and pitch down, keep straight with rudder and hold the altitude with increasing backpressure on elevator.

Through ____ kts, or when the aural stall warning is heard, select carb heat cold, as full power will shortly be reapplied.

Stall Warning Symptoms

Decreasing Airspeed

The first true symptom is a decreasing airspeed. Low airspeed and a high nose attitude are not **always** present in the approach to the stall, for example, the high-speed stall as a result of pulling out of a dive too sharply. Therefore, although it is desirable to inform the student that a high nose attitude and low airspeed are indicators of an approaching stall for most phases of flight, they will not always be present.

Less Effective Controls

The next symptom is less effective controls as a result of the lowering airspeed.

Stall Warning Device

Control effectiveness is followed by the stall-warning device that, although this is not a true symptom as, being mechanical, it may not work. The type and operation of the stall-warning device fitted to the aircraft is described.

Buffet

The last generally noted symptom is the buffet. This is caused by the turbulent airflow from the wings striking the empennage. The effects of buffet are least noticeable in high-wing/low-tailplane aircraft types, such as Cessnas. This is because the airflow breaking off the high wing, combined with the high nose attitude, results in most of the turbulent airflow missing the empennage. Whereas in the low-wing/high-tailplane arrangement, for example the Piper Tomahawk, the turbulent airflow directly strikes the empennage and is very apparent. (For the Tomahawk, a large part of the turbulence is created by the breakdown of airflow over the canopy.)

At this point, as a result of the low airspeed, elevator effectiveness has been reduced to the point where no further increase in angle of attack can be achieved, even though the control column is held well or fully back. This results in the aircraft sinking and the change in relative airflow causes the critical angle to be exceeded. This amount of detail is not generally given in the pre-flight briefing, and the decision to include or exclude it should be referred to your supervisor or CFI.

The aircraft stalls, **altitude is lost**, and (generally) the nose pitches down.

Recovery

The recovery is broken down into two distinct parts: to unstall the aircraft, and to minimise the altitude loss.

To unstall the aircraft, the angle of attack must be reduced. Even though the aircraft nose may have pitched down at the stall, the angle of attack is still high because the aircraft is sinking. Since increasing the backpressure (or pulling back) increased the angle of attack, decrease the backpressure (or check forward). The student should be advised that check forward with the elevator is a positive or brisk control movement but not a **push**.

In addition, no aileron should be used; ailerons must be held neutral or centralised for reasons that are not generally discussed in this briefing. However, the correct use of aileron **must** be stated at this time because, in overlearning a motor routine to produce an automatic response, you must get the sequence right the first time (see Chapter 1 primacy and Chapter 5 demonstration-performance method).

You should be attempting to introduce stalling in its simplest, basic and least violent form. Therefore, every effort should be made to avoid the wing-drop. If the aircraft has a known tendency to wing-drop in the basic configuration it may be necessary to explain this tendency and the result, as well as the reason for no aileron in the recovery (refer CFI).

If an explanation is required, keep it as simple as possible at this level. For example, “For various reasons one wing may stall before the other and this will produce a roll; ignore the roll (no aileron, aileron central, aileron neutral) and simply check forward”.

Your choice of terms - check forward; relax backpressure; ailerons neutral; no aileron or ailerons central - should match your airborne patter.

It should be made clear that reducing the angle of attack is all that is needed to unstall the aircraft. The aircraft will enter a descent, and the student can now regain straight-and-level from the descent (PAT). The altitude loss will be about 300 ft using this method.

However, to minimise the altitude loss – **power** plus **attitude** equals performance.

For the least loss of altitude, the maximum amount of power is required (hence carb heat cold during the entry) so smoothly but positively apply full power (prevent yaw – keep straight) and raise the nose smoothly to the horizon. There is no need to hold the nose down, as excessive altitude will be lost, but increasing backpressure too rapidly, or jerking, may cause a secondary stall.

Nose-on-the-horizon is used as the reference attitude. Of the attitudes the student is familiar with, the level attitude is too low, since under inertia the aircraft will continue to sink, resulting in unnecessary altitude loss. Alternatively, the climb attitude is too high, as the pitch-up created by full power combined with inertia as a result of the control input may result in a secondary stall. In addition, the student should be discouraged from thinking that pulling back will make the aircraft stop sinking – that's how the stall was entered.

A compromise attitude is required to arrest the sink and allow the aircraft to accelerate to the nominated climb speed. The simplest attitude to use is to put the top of the nose cowling just on the horizon. For some light aircraft this attitude is the same or similar to the climb attitude, but at least the student has not been encouraged to try to climb by simply pointing the aircraft up.

The expected altitude loss should be stated, for example, not more than 100 ft.

The aircraft should be held in the nose-on-the-horizon attitude until the nominated climb speed is reached and then the climb attitude selected.

Common practice is to use the recommended or normal climb speed, for example 70 kts. However, you may nominate speed for best angle of climb or for best rate of climb (refer CFI).

Straight-and-level flight should be regained at the starting altitude and the reference point or heading regained if necessary.

The student should be advised that, through practice and a coordinated movement of stick forward/full power, the altitude loss can be reduced to less than 50 ft.

Less than 50 ft is not an objective of this lesson. Your primary goal is to ensure that the student learns to recognise the symptoms leading up to the stall and the correct sequence of control inputs for recovery. Increasing speed of correct execution is a long-term goal achieved through regular practice.

All stalling exercises should finish with a recovery at the incipient stage, more commonly referred to as the onset. This is to emphasise that, under normal conditions of flight, the stall is avoided.

The purpose of this exercise is to recover at onset, which means at the stall warning or buffet.

The stall itself is simply the stall and is sometimes referred to as fully developed, meaning that the stall has occurred. A fully developed stall does not **necessarily** imply a wing-drop. In fact, the wing-drop is the first symptom of the incipient stage or onset of a spin, with fully developed meaning that the spin has stabilised.

The expected altitude loss from a recovery at onset (depending on which symptom is first detected) should be stated, for example, less than 50 ft. With practice and improved situational awareness, this altitude loss can be reduced to zero – as the aircraft is not permitted to stall.

It is common practice to depict the decreasing altitude loss diagrammatically; for example:

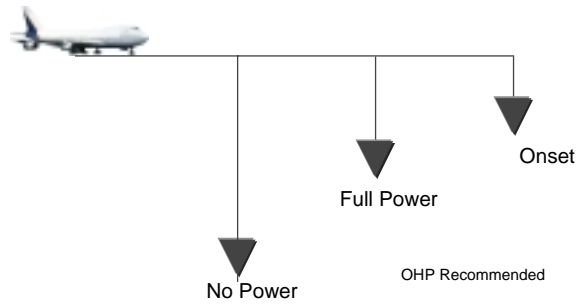

Airborne Sequence

Because of the importance of training the student to avoid the inadvertent stall, this exercise is broken down into many more small steps than the normal airborne sequence.

The airborne sequence starts with a pure **demonstration of the basic stall** and recovery rather than the recovery at onset. This is because, although the student is being taught to avoid the stall, they still need to experience what it is they are trying to avoid. During the demonstration the student should be advised to observe the high nose attitude.

In line with the objective of recognising the symptoms that warn of an approaching stall, the next step is to carefully **demonstrate the symptoms**.

One method of doing this effectively is to slow down the entry so that the patter can be synchronised to each of the symptoms as they appear. This is achieved by informing the student that in order to give them a good long look at each of the symptoms, no attempt will be made to maintain a constant altitude during this entry.

As this is not the entry you want the student to use, and to avoid distractions, no follow-through takes place.

The entry is pattered as reference point, reference altitude, carb heat hot, reduce power, keep straight (not balanced). Keep straight reminds the student to look outside at the reference point, whereas maintain balance requires the student to look inside at the balance indicator – and you want the student looking outside.

From this point on you can adjust the amount of backpressure, allowing the aircraft to sink as required, to synchronise a calm, carefully worded patter to match the symptoms. For example, with practice you will be able to synchronise the words “and the stall warning sounds like [pause] that”.

The aircraft is **not** being held in the stall. There is no purpose in holding an aircraft in the stall when the objective of the exercise was to teach the student how to avoid the stall.

At the stall, the nose pitch-down is observed and the normal recovery carried out by you without patter.

The amount of altitude lost during this demonstration, as a result of adjusting the backpressure to slow down the entry, depends on how fast you talk and how much power is used. With power at idle and a moderate to slow patter rate, you can expect to descend about 400 ft before the stall. Therefore, if power at idle is used, the demonstration should start from an altitude suitable to still achieve recovery by 2500 ft agl. An alternative method, during the entry when you patter reduce power, is to set power at about 1500 rpm (or less) without comment to the student (who is unlikely to notice anyway). The advantage of this is that, at the same patter rate, less altitude will be lost before reaching the stall, and less time will be required to climb back to a suitable starting altitude. The disadvantage of this method is that the slipstream masks the buffet, making it harder to detect, and, depending on the aircraft, may make it more prone to a wing-drop (refer CFI).

If the sink (as a result of inadequate elevator effectiveness to raise the nose to the stall) was discussed in the air exercise, this can be demonstrated only from a level entry. It is difficult to detect and may register as a ROD on the VSI, even though the

elevator is held well or fully back, before the nose pitches down. The decision to include this demonstration depends on whether or not it was discussed in the air exercise, the aircraft type, and ultimately the CFI.

Once the symptoms have been carefully demonstrated there is no need to rattle them off during **every** stall entry. Your patter can now be directed at the recovery.

The only thing that recovers the aircraft from the stall is a reduction in the angle of attack. Therefore, the entry and recovery without power is **pattered** with the **student following through** for the reasons given in Campbell¹²⁷. In addition, the student is given the opportunity to carry out the entry and recovery without power because this is the simplest recovery, and because checking forward centrally, when the nose is pitching down is not a natural reaction but must be made through a conscious decision.

With the aircraft in a glide descent the student **may** be asked to put the aircraft into straight-and-level flight (PAT) or directly into a climb (refer CFI) and the altitude loss noted.

Minimising the altitude loss is next pattered with follow-through. This requires the application of full power earlier than the previous student practice and smoothly raising the nose to the horizon until the nominated climb speed is reached. You must ensure that during the demonstrations accurate altitude holding is maintained throughout the entry, if the benefits of power in reducing the altitude loss are to be seen clearly.

From this point the airborne sequence follows the standard sequence, with the student being talked through and practice for evaluation completed. Remember, for this lesson, the correct recovery sequence of events is more important than speed or coordination of execution.

In completing the airborne sequence, a recovery at onset should be carried out by the student. Common practice is to nominate a symptom at which the recovery will be initiated, for example, 60 kts, stall warning, or buffet (if the latter is easily detected).

It should be emphasised that, since the student can now recognise the symptoms leading up to the stall, there is no reason – other than controlled practice to overlearn an automatic initial response – why the student should allow the stall to occur.

¹²⁷ 1994, p.10B-25

BASIC STALLING

OBJECTIVES:

1. To recognise the symptoms of an approaching stall, experience the stall itself & to recover with minimum height loss. [Smooth Air < 150 ft]
2. Through improved situational awareness, prevent the inadvertent stall from occurring.

PRINCIPLES OF FLIGHT:

$$L < \frac{A/A}{A/S}$$

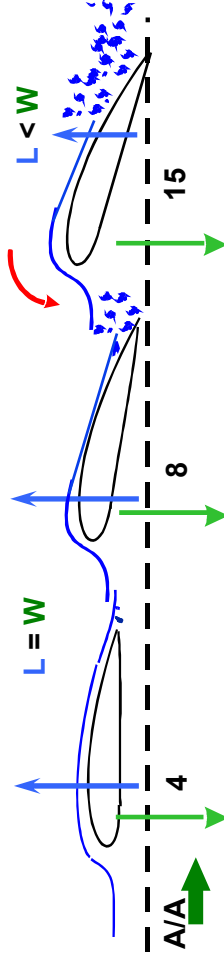

At the stall: Lift decreases and the A/C sinks, the centre of pressure moves rapidly rearwards causing the nose to pitch down

To unstall the A/C we must decrease angle of attack, so we **check centrally forward** on the control column

AIR EXERCISE:

Entry

- HASELL / HELL checks complete
- Reference point (DI)
- Carb heat on, smoothly close throttle
- Keep straight and maintain altitude
- At ___ kts (or stall warning), carburettor heat off

Symptoms

- Decreasing airspeed
- High nose attitude
- Low airspeed
- Quiet
- Less effective Control
- Stall warning
- Buffet

At the stall - The A/C sinks and the nose pitches down

Recovery

- **To unstall**
 - **Control column centrally forward**
 - Note height loss (about 300 feet)
- **To minimise height loss**
 - **Full power** (Keep straight, right rudder)
 - Smoothly raise the nose to the horizon
 - Note height loss (about 100 feet)
 - At ___ kts Climb to reference height & regain S & L (reference point if required)
 - (If a wing drops, control yaw with opposite rudder, keep ailerons neutral)

Stall prevention through situational awareness

- At the 'onset' (symptom of the approaching stall recognised)
- C/C centrally forward
- Full power
- **Co-ordinate with practice**
- **Note height loss** (about 50 feet; less with early recognition)

HUMAN FACTORS:

Situational awareness

- Recognise symptoms
 - Hazardous thoughts
 - Decision making
- ### Stress
- Overlearning - Initial recovery
 - Desensitise - discomfort

AIRCRAFT MANAGEMENT:

Hasell / Hell checks (OHP)

- Throttle** - smooth but positive
- Carb Heat:** Hot below ___ rpm
- Cold at ___ kts (or stall warning)

Pre-flight - loose articles check

No Pax.

Advanced Stalling

Advanced stalling deals with the various factors that affect the observed airspeed and nose attitude at the stall.

Some organisations prefer to leave this lesson until after first solo and circuit consolidation; others prefer to revise the basic stall and introduce these factors before the circuit. The decision as to where this lesson will be given in the flying training syllabus is entirely at the discretion of the CFI, not individual instructors.

Introduction

Although the aircraft always stalls when the aerofoil is presented to the airflow at too high an angle ($>\approx 15$ degrees) most aircraft are not fitted with an angle-of-attack indicator. Therefore, it is common practice to refer to the aircraft stalling speed (V_S – Velocity at Stall).

The airspeed and nose attitude will vary depending on the aircraft configuration (speed, power, flap and gear settings) and therefore airspeed and/or nose attitude are not reliable indicators unless the configuration for the phase of flight is considered. As was seen in the climb, the aircraft has a high nose attitude and a low airspeed but is nowhere near the stall.

The purpose of this exercise is to revise the causes of the stall and to further improve situational awareness by comparing the aircraft nose attitude and airspeed approaching the stall in various configurations, with emphasis on avoiding the stall by recovering at onset.

Objectives

1. To revise the basic stall. Explain or revise that this means to stall the aircraft and recover with minimum altitude loss.
2. To observe the effect of power and/or flap on the aircraft speed and nose attitude at the stall.
3. To improve situational awareness by avoiding the stall, through recognition of the onset and taking the appropriate recovery action.

Principles of Flight

The manufacturer provides stalling speeds for one or more configurations as a guide to the pilot, for example, from level flight with a slow deceleration, power at idle, and flap up, when this aircraft reaches the critical angle the airspeed will read _____ kts

Although the critical angle remains constant, the stalling airspeed will vary for other configurations and with several factors.

The full flap, no power (or similar) stall speed may be given as an example.

Lift primarily varies with angle of attack and airspeed. Since the critical angle cannot be altered, anything that increases the requirement for lift will require an increase in airspeed to produce that lift. Therefore, when the critical angle is reached the airspeed will be higher.

Anything that decreases the requirement for lift will decrease the airspeed observed at the stall.

Weight – an increase in weight will require an increase in lift, resulting in an increase in the stalling speed.

Loading - explaining this effect is one reason why advanced stalling is often left until after solo circuits and steep turns; at this level the explanation is kept as simple as possible.

Loading, or load factor, is the name given to the force/acceleration that the aircraft must support, for example, in pulling out of a dive. When you ride a roller coaster, at the bottom of the dip you feel heavier as you're pushed into your seat by the force/acceleration of changing direction. You haven't actually gained weight, but it feels that way. For an aircraft this is often referred to as apparent weight, or G, and this increase in apparent weight increases the requirement for lift, and thus it increases the stall speed.

Ice or damage – if ice forms on the wing, or the wing is damaged, the smooth airflow over that part of the wing will be disturbed, allowing the airflow to break away earlier. This increases the requirement for lift and therefore the stall speed. The effect of ice is twofold in that it also increases the aircraft weight.

In flight, generally ice will form on the airframe only if the aircraft is flown in cloud.

The most common danger from ice in New Zealand is its formation on the wings and tailplane of aircraft parked overnight, and sometimes it is so thin and clear that it is hard to detect. No attempt should ever be made to take off with ice or frost on the wings or tailplane, because of its effects on the smooth airflow and the resulting increase in stall speed – which may be well above the normal rotate speed.

Various articles from *Flight Safety* magazine and accident reports, highlighting this accident cause, should be included with the student's handout on this lesson. In addition, hosing ice off is not a total cure, as water may not completely drain from the control surfaces or hinges and may then refreeze during a climb to altitude. This may cause control flutter, as the control surfaces are no longer correctly balanced, or the controls may become immovable.

Centre of Gravity (C of G) position¹²⁸ is not commonly discussed, because the small amount of movement permitted within the range has a minimal effect on the stalling speed. However, the possibility of losing control, as a result of operating **outside** the C of G limits, **may** be discussed.

Power – if the aircraft could climb vertically there would be no requirement for lift at all. So when thrust is inclined upwards, it decreases the requirement for lift and reduces the stalling speed. In addition, the slipstream generated by having power on increases the speed of the airflow and modifies the angle of attack (generally decreasing it) over the inboard sections of the wing. The increased airspeed increases the lift and reduces the aircraft stall speed, and the modified angle of attack increases the nose-high attitude.

Flap – increases lift and therefore the stalling speed is reduced. However, flap also changes the shape of the wing, and this results in a lower nose attitude at the stall.

Slats and slots are not normally discussed in the pre-flight briefing unless the aircraft is fitted with them.

The effect of flap on the lift/drag ratio should be discussed, or revised, so that the gradual raising of flap during stall recovery has relevance.

Although flap increases lift, it also increases drag. Generally, about the first 15 degrees of flap extension increases lift with little adverse affect on the L/D ratio. It should be appreciated however, that any use of flap will **decrease** the L/D ratio.

The application of any further flap increases drag rapidly, adversely affecting the L/D ratio.

¹²⁸ refer Campbell, 1994, p.10B-19

The point at which drag rapidly increases varies with aircraft and flap type, but this is usually at the flap setting recommended for a soft-field takeoff.

Aircraft Management

Revise the requirement to carry out all stalling practice in a safe environment through HASELL/HELL checks.

Depending on where this exercise comes in the syllabus, the use of carb heat may or may not require revision.

Human Factors

The effects (ADVISE mnemonic) of **D**isorientation, **V**ision and **S**tress are the prime considerations in this briefing.

Situational awareness is the prime consideration of this exercise. The student should strive to improve situational awareness by integrating the observed attitude and airspeed with the aircraft configuration and flight phase, as well as the position of the aircraft within the training area and in relation to other aircraft.

Reduction of stress through practice will desensitise the student.

Air Exercise

The student should start by demonstrating at least two basic stalls, with recovery at onset and with minimum height loss. This is intended to refamiliarise the student with the stall and help the desensitising process.

Primarily this exercise is leading to the realisation by the student that in the approach configuration the attitude observed at the stall is noticeably lower than might be expected, and that throughout a normal approach the aircraft nose is held well below the horizon. Therefore, the emphasis is on the observed attitude at the stall **more than** the indicated airspeed. In addition, the range of airspeeds at the stall, when entered from level flight with a slow deceleration, is not large enough to be convincing.

You will demonstrate a stall, with recovery at onset, with some power, and no flap. Observe the nose-high attitude and lower airspeed. The more power used, the more noticeable the increased nose-high attitude and the lower the stall speed. However, it should not be your intent to cause anxiety to the student, but rather to show the high nose attitude and lower airspeed at the stall with power on. In addition, at high power settings with no flap, the entry can be considerably prolonged (unless altitude is gained). Therefore, normally somewhere between 1500 and 2000 rpm should be sufficient (refer CFI).

You will then demonstrate a stall, with recovery at onset, with full flap and no power. Observe the nose-low attitude, often similar to the straight-and-level attitude, and the lower airspeed.

There is no reason why this demonstration should not be carried out with full flap to emphasise the change in attitude and airspeed at the stall.

The use of attitude windows during the briefing to show the variation in attitude is highly recommended.

Once the difference in attitude and airspeed at the stall as a result of the aircraft configuration has been observed, the effects of a combination of power and flap on the observed attitude and airspeed is introduced. Commonly, the approach configuration is used for this purpose.

Entry

HASELL checks are completed and a prominent outside reference point on which to keep straight is nominated.

Nominating a reference altitude is a function of the HASELL/HELL checks.

From level flight, carb heat is selected hot and the power smoothly reduced to _____ rpm. As the nose will want to yaw and pitch down, keep straight with rudder and hold the altitude with increasing backpressure.

Below _____ kts (within the white arc) select full flap gradually and prevent the tendency for the aircraft to gain altitude or 'balloon' with the rapid increase in lift, by checking forward or relaxing the backpressure.

Full flap is recommended so that raising of flap can be practised in the recovery sequence. This is not necessarily the configuration that will be used to induce the wing-drop stall.

Through _____ kts, or when the aural stall warning is heard, select carb heat to cold, as full power will shortly be reapplied.

Stall Warning Symptoms

Decreasing Airspeed and High Nose Attitude

The first symptom is decreasing airspeed. The rate at which the airspeed decreases will be affected by the amount of power and flap being used, probably faster in this case with full flap.

Low airspeed and a high nose attitude are not **always** present in the approach to the stall, as was demonstrated in the full flap, no power case. However, for most phases of flight, low airspeed and high nose attitude are valid indicators; so too is quietness.

Less Effective Controls

The next symptom is less effective control as a result of the lowering airspeed. However, the effectiveness of the rudder and/or elevator will be determined by the amount of power being used. In this case, the elevators will generally retain sufficient effectiveness to bring the aircraft to the critical angle without a sink developing.

Stall Warning Device

The stall warning device (which is not a true symptom) follows this. Because the stall speed with power and/or flap is reduced, the stall warning will sound later, at a lower airspeed.

Buffet

The last symptom is the buffet. The amount of buffet detected depends on the mainplane/tailplane configuration, as discussed in basic stalling. In both the high-wing/low-tailplane and low-wing/low-tailplane types, the flap deflect the airflow down onto the tailplane, and the buffet will be more noticeable. This will depend on the power setting used, as the slipstream may mask any increased effect. In the low-wing/high-tailplane arrangement there may be little change, but again depending on slipstream effects.

Remind the student to observe the attitude and that, if the aircraft stalls, **altitude will be lost** and the nose will pitch down.

Recovery

The recovery is still in two parts, but coordination and speed of execution are increased.

To unstall – decrease the backpressure, or check forward, with ailerons neutral. The student should be reminded that check forward with the elevator is a positive or brisk control movement but not a push.

The reasons for ailerons being held neutral or centralised need not be discussed in this briefing. As, other than the initial student practice, all recoveries will be made at onset, the aircraft is not permitted to stall, and no wing-drop will occur.

The correct use of aileron **must** be reinforced to produce the required automatic motor routine response.

To minimise the altitude loss – full power is smoothly but positively applied – use rudder to keep straight – and the nose is smoothly raised to the horizon. There is no need to hold the nose down as excessive altitude will be lost, while increasing backpressure too rapidly, or jerking, may cause a secondary stall.

The result is sufficient to arrest the sink and minimise the altitude loss.

Hold the aircraft in the nose-on-the-horizon attitude and reduce the flap setting (as appropriate to aircraft type) immediately. Do not raise all the flap at this stage, for example in a PA 38 reduce to one notch of flap, or in a C152 reduce the setting by at least 10 degrees. Any benefit of attitude plus power will be reduced the longer the aircraft is held in the nose-on-the-horizon attitude with full flap extended.

A pitch change will occur as flap is raised if uncorrected, therefore, the nose attitude must be held constant. In addition, flap should not be raised with the nose **below** the horizon, as this will result in **considerable** altitude loss.

Before raising the remaining flap, there are three criteria that must be met, safe altitude, safe airspeed (above a minimum **and** accelerating), and a positive rate of climb (to counter the sink as a result of reducing lift through flap retraction). When these conditions have been met, raise the remaining flap and counter the pitch change. The aircraft will continue to accelerate, and at the nominated climb speed, select the climb attitude.

Common practice is to use the recommended or normal climb speed, for example 70 kts. However, you may nominate speed for best angle of climb or for best rate of climb (refer CFI).

Straight-and-level flight should be regained at the starting altitude, and the reference point or heading regained if necessary.

The student should expect an altitude loss of less than 50 ft, reducing to zero with practice and early recognition.

The possibility of a wing-drop during this exercise is extremely remote, but you may wish to discuss or revise the effects of one wing stalling before the other. The depth of this discussion will be affected by where this briefing is given in the syllabus, and possibly by the aircraft type (refer CFI).

Airborne Sequence

The student should be capable of positioning the aircraft within the training area at a suitable altitude, completing the necessary checks, and carrying out the basic stall and recovery. Your assistance is given only as required. The amount will vary with several factors and where this lesson is given in the syllabus.

During the demonstrations or follow-through of the stall, with power only and then flap only, you must ensure that a constant altitude is maintained, as any tendency to zoom (gain altitude) during the entry will affect the nose attitude observed at the stall.

After the initial basic stall, it is recommended that all recoveries be carried out at onset to improve situational awareness and to reinforce the concept that the student should not allow

the aircraft to stall. For the purposes of this exercise, it is recommended that the stall warning is nominated as the symptom at which recovery will be initiated and the aircraft nose attitude and airspeed be observed.

The advantage of this is that situational awareness is improved through earlier recognition, and the effect of power and/or flap on the aircraft nose attitude and indicated airspeed can still be seen without actually stalling the aircraft.

If the stall warning is not operative, the buffet may be used as the symptom at which recovery is initiated. The only disadvantages of this are that, with power on, the buffet may be very difficult to detect, and greater care must be taken by you or the student to prevent the stall occurring.

For the purposes of this exercise, nominating an airspeed at which to recover would not permit the effects of aircraft configuration on the observed airspeed at the stall to be seen.

During the entry and recovery, you should emphasis eyes outside on attitude and keeping straight using the reference point, for it will be shown in the wing-drop stall that, if the aircraft is permitted to yaw, one wing **will** stall before the other. In addition, smoothly raising the nose to the horizon and countering the effects of raising flap should be emphasised.

If this lesson is given after solo and circuit consolidation, it is recommended that the next lesson should be wing-drop stalls.

ADVANCED STALLING

OBJECTIVE:

- To revise the basic stall.
- To see the effect of power/flap on the A/C's speed & attitude at the stall.
- To improve situational awareness through early stall recognition and recovery.

PRINCIPLES OF FLIGHT:

The aircraft stalls at an angle of attack (the critical angle).

The aircraft's speed (Vs) when this angle is reached varies.

For this A/C (from level flight) - ___ Knots Clean, no power

- ___ Knots Full Flap, no power

Factors Affecting Vs

Weight: ↑ W requires ↑ lift at any A/A, therefore A/S is ↑ at stall

Loading: ↑ 'G' requires ↑ lift therefore A/S is ↑ at stall

Ice or Damage: requires ↑ lift therefore A/S is ↑ at stall

Power/Slipstream: requires ↓ lift therefore A/S is ↓ at stall
aircraft's nose attitude is higher

Flap: increases lift and changes wing shape therefore A/S is ↓ at stall
aircraft's nose attitude is lower

Although flap ↑ Lift, it also ↑ Drag

Drag: ↑ rapidly when more than ___ degrees is extended

Any use of flap will reduce the L/D ratio

AIR EXERCISE:

1) Student practice - Basic Stall

- Basic Stall (recovery at onset)

Note: Nose Attitude and Vs

2) Instructor Demo - Stall with Power

Note: Nose Attitude and Vs

- Stall with Full Flap No Power

Note: Nose Attitude and Vs

3) Stall in the Approach Configuration

- Approach power OHP Recommended

(recovery at onset - stall warning) - Full Flap

Entry

- Hasell/Hell checks, Ref point

- Carb Heat Hot, power as required

Keep Straight- Maintain height through ↑ BP

- Below ___ Kts (white arc), Full Flap

- Through ___ Kts (or stall warning) Carb Heat Cold

Symptoms

- Decreasing airspeed

- Less effective controls

- Stall warning (later or at a lower A/S)

- Buffet (more noticeable or unchanged)

NOTE Nose Attitude

IF the aircraft stalls, height will be lost - nose pitches down.

Recovery

- To Unstall: control column centrally forward

- To Minimise Height Loss: Full Power (Keep Straight)

- Smoothly raise nose to horizon (Wings level)

- Reduce from full flap setting (as appropriate for A/C type)

- At a safe height, through ___ kts, with a positive ROC

- Raise remaining flap gradually

- At ___ kts (nominated climb speed) select climb attitude

- Climb to ref altitude (regain ref. point if required)

AIRCRAFT MANAGEMENT:

HASELL / HELL Checks

Carb Heat - (if applicable)

Hot < ___ rpm

Cold at ___ Kts or stall warning

HUMAN FACTORS:

Situational Awareness

- Stalling Cues

- Instinctive Recognition

- Desensitise

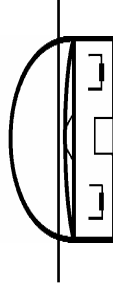
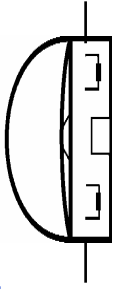
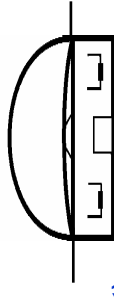

Circuit – Introduction

The circuit is an orderly pattern used, in a potentially high traffic density area, to position the aircraft for landing and minimise the risk of collision.

The normal lefthand circuit, assuming nil wind or at least wind straight down the runway, is the basis of this briefing, with variations to this scenario introduced gradually. You should aim to introduce this lesson under ideal conditions. Obviously this will not always be possible and the briefing will need to be modified for the actual conditions on the day, for example, a righthand circuit in use. In addition, the weather conditions for your aircraft type and aerodrome that are considered acceptable for the introduction of this lesson should be discussed with your supervisor or CFI

Some organisations split the circuit into two briefings and air exercises. Commonly, the takeoff, climb out, crosswind and achieving straight-and-level at the beginning of the downwind leg is separated from the end of downwind, base, approach/final and landing.

As the briefings leading up to the circuit in this guide have specifically dealt with the configurations to be used on each leg of the circuit, this split method has not been used here. However, it should be appreciated that this alternative method is not discouraged (refer CFI).

Introduction

Airfields attract aircraft, therefore rules and procedures are required to maintain an orderly sequence or flow of traffic. Knowing that all aircraft **should** be following these published procedures makes it easier to identify which runway should be used, where other aircraft are (or can be expected to be), and who has the right of way (or priority) in the sequence to takeoff or land.

Having the right of way does not absolve the pilot-in-command from avoiding a collision.

The standard circuit pattern or procedure, and the rules to be employed around specific aerodromes are published in the New Zealand Aeronautical Information Publication (NZAIP). The rules governing circuit procedures are contained in rules 91.223 and 91.225

This is a good time to advise or remind the student to order a copy of the relevant parts of the AIP.

Although the aerodrome circuit is primarily designed for the expeditious flow of traffic to and from the aerodrome, the circuit is often flown to practice the various phases of flight and the landing.

Objectives

To takeoff and follow published procedures that conform with the aerodrome traffic circuit, avoiding conflict with other aircraft, and to land using the most suitable runway.

Principles of Flight and Considerations

Takeoff

Slipstream

The effect of slipstream is to apply a force on the port side of the vertical tail fin, and this will tend to yaw the aircraft to the left at high power settings. This effect is greatest during the takeoff roll as a result of the high power and low airspeed.

Torque

The effect of torque, the force that tries to rotate the aircraft rather than the propeller, is to cause increased downward pressure to be applied to the port main wheel. This results in increased resistance on this wheel, yawing the aircraft to the left.

There are two more effects, but these apply more significantly to tailwheel aircraft.

Asymmetric blade effect is the result of the down-going blade of the propeller meeting the relative airflow at a higher angle of attack than the up-going blade. This effect is noticeable with tailwheel aircraft; it will only affect tricycle types in the rotate or climb. It results in the thrust force being slightly offset to the right (in clockwise rotating engines, as viewed by the pilot) and thus a tendency to yaw to the left.

The gyroscopic effect occurs when the tail is raised to the level attitude. This causes a force to be applied to the propeller disc, the effect of which will be to produce a turning moment, which acts at 90 degrees in the direction of propeller rotation. Gyroscopic effect has no practical application to tricycle types.

Keeping Straight

Although all of the above effects tend to yaw the aircraft nose to the left, in modern low powered training aircraft they are not significant and need not be explained in too much detail (or they may be omitted at CFI discretion).

Use of the OHP is recommended for the above factors that may cause the aircraft to swing on takeoff. For a detailed explanation of these effects refer to Campbell or Kermode.

What **should be** emphasised, in the pre-flight briefing, is that rudder should be used as required to keep the aircraft straight during the takeoff roll by reference to a feature at the **far end** of the runway. Because the effects that cause swing on takeoff will be negated by emphasis on keeping straight, it is recommended that they be discussed first and virtually dismissed before discussing the more important aspects of the effects of wind on the takeoff.

Crosswind

The tendency for the aircraft to weathercock during the ground roll or while taxiing, as a result of crosswind, is explained, and the need to keep straight on the reference point is restated.

Headwind

If the aircraft was parked facing into the wind, and the wind was blowing at ____ kts, the aircraft would be about to get airborne, and they sometimes do in strong winds if not tied down. Therefore, little or no acceleration or ground roll would be required for the aircraft to fly.

Tailwind

A takeoff with the wind, would require the aircraft to be accelerated to the wind speed just to bring the airflow over the wing to a standstill, a further ____ kts would be required to get airborne, greatly increasing out of all proportion the takeoff distance required.

Climb Angle

If the wind was blowing at 70 kts and the aircraft was in a 70-knot climb, to a ground observer the aircraft would appear to rise like an elevator, as the distance travelled forward

over the ground would be zero. Therefore, the angle of climb is increased (ie, is steeper) into wind.

Takeoff Into Wind

For the above reasons, all takeoffs are into wind, to minimise the ground roll and takeoff distance, and to improve the climb angle.

Ground roll is from brake release to liftoff, whereas takeoff distance is the distance travelled to climb to 50 ft; both are affected.

Power

Power controls the altitude, so all takeoffs use full power.

Flap

Flap increases lift and drag. Because of the drag increase, **most** light aircraft Flight Manuals do not recommend the use of flap for a normal takeoff.

Landing

Wind

Landing into wind reduces the aircraft speed over the ground or groundspeed, requiring less stopping distance and therefore a shorter landing distance and ground roll.

Ground roll, is wheels-on-the-ground distance, and landing distance is measured from 50 ft above the threshold to full stop; both are affected.

Once again if the headwind is 70 kts the aircraft would not need to move forward at all to descend at 70 kts. Therefore, a headwind steepens the approach.

Flap

Flap increases lift and drag. The increased lift lowers the stall speed and permits a lower and safer landing speed, which will also reduce the ground roll. The increased drag allows a lower nose attitude to be selected for the same airspeed, and it increases the rate of descent, steepening the approach.

At first, approaching steeply may not sound desirable to the student, so the improved obstacle clearance must be emphasised. In addition, the low nose attitude that the use of flap permits (without an airspeed increase) provides excellent forward visibility.

Power

Power controls the height or rate of descent¹²⁹. As discussed in descending, increasing or decreasing the power alters the rate of descent.

The increased rate of descent as a result of using flap is countered by the use of power to control the rate of descent. In addition, the use of power provides a slipstream effect that makes the rudder and, more significantly, the elevator more effective. Therefore, for all the reasons given above, in a modern light aircraft the normal approach is a powered approach employing full flap. The various reasons for limiting flap during the approach will be discussed under the non-normal circuits.

Runway Length

A major factor that influences the choice of a suitable runway is runway length. This is a good time to introduce the second most useless thing to a pilot – **runway behind you**. Also, the student should be left in no doubt that sufficient runway length for takeoff and landing **must** be shown **before** starting the takeoff or landing approach.

¹²⁹ Campbell, 1994, p.13-19

As this introductory briefing to the circuit contains much new information for the student to assimilate, you only need tell the student that you have carried out the necessary calculations. However, before the third or fourth (refer CFI) revision exercise of circuits, a formal briefing or discussion of the Group Rating System and its application **must** be given. Before the fifth or sixth (refer CFI) revision of circuits, the calculation of takeoff distance by reference to the aircraft Flight Manual **must** be given¹³⁰.

Your ability to explain these methods of confirming sufficient runway length for takeoff and landing to a student of average ability will be examined.

The effects of density altitude, weight, surface and slope are discussed during circuit revision when discussing calculation of required takeoff and landing distances. Therefore, they need not be formally introduced in this briefing, **unless** any are pertinent to **your** normal circuit (refer CFI). The effect of these factors will be revised (not taught) during the briefings on Maximum Performance Takeoffs and Minimum Distance Landings or Short Field Landings.

During circuit revision, your supervisor will fly with the student on regular occasions, to monitor the student's progress and provide feedback on your instruction. This does not prevent you from carrying out a briefing or discussion, before the revision flight, on any of the subjects to be covered before first solo.

Throughout circuit revision, formal briefings or guided discussions will be required to ensure that all environmental factors affecting taxiing and the circuit have been learnt by the student before presenting your student to your supervisor for a pre-solo check flight.

The effects of windshear may be discussed in this briefing (refer CFI) or, as suggested in this guide, incorporated in the second lesson on circuits.

Aircraft Management

The right-of-way rules applicable to the circuit (on the ground and in the air) directly affect aircraft management and situational awareness. As there will be several pre-flight briefings during circuit revision, the right-of-way rules can be spread over these briefings. The suggested rules for discussion in this briefing are: aircraft taking off and landing have right of way over all other traffic; aircraft landing have right of way over aircraft taking off; aircraft established in the circuit have right of way over joining traffic; and the good aviation practice considerations of avoiding overtaking or cutting in.

The rules or good aviation practice considerations most pertinent to your operation should be considered first, for example, circuit direction and altitude. The rules suggested for discussion here are **not necessarily** the most appropriate.

Correct use of the aircraft radio and checklists will influence situational awareness.

Throughout circuit training, you should place more and more emphasis on the student's command decision-making.

Human Factors

The considerations (ADVISE mnemonic) of **D**isorientation, **V**ision, **I**nformation processing and **S**tress are most relevant to the circuit. **E**alth is relevant to all flight.

Disorientation is minimised through situational awareness. Situational awareness is improved through communication (radio, ATIS) and pre-flight/in-flight planning as well as regular practice. To improve situational awareness, the student should be asked to describe the wind direction and strength.

¹³⁰ refer NZ Flight safety, 1991

Visual landing cues¹³¹ should be introduced in this lesson, and the various aspects of visual limitations previously discussed should be revised over the circuit revision briefings.

The use of checklists and mnemonics to aid information processing is revised, and the possibility of reaching a learning plateau during circuit training, where progress may appear to be minimal, may be discussed.

The effects of stress are best countered through regular practice or overlearning (to produce competency), planning, prioritising and visualisation. These aspects will be discussed throughout the circuit briefings.

Air Exercise

Common practice is to draw the circuit pattern and number the various points around the circuit at which the listed actions are carried out.

The OHP or aerodrome model are possible ways of presenting this information.

Since each lesson leading up to the circuit involved one or more legs of the circuit, this lesson is primarily revision, with emphasis on the new material being introduced, the landing.

Checklists, and if applicable the takeoff safety brief, should have been gradually introduced and learnt throughout the previous lessons.

Takeoff

The student will have practised the takeoff, or at least followed through, probably as early as straight-and-level. Therefore, only the main points are revised, for example, reference points, keeping straight and rotate speed if applicable.

Two reference points should be chosen on lining up (backed up by the DI), one at the far end of the runway on which to keep straight during the takeoff roll, and one high up to keep straight on during the climb.

This second reference point may need to be modified, if a crosswind is present, to prevent drift and provide a straight track over the ground along the extended centre line.

During the normal takeoff the aircraft is seldom actually rotated. Common practice is to use elevator backpressure to take the weight off the nosewheel as the aircraft accelerates. The aim is to reduce the loads on the nosewheel (a relatively weak structure) and reduce friction. The aim is **definitely not** to haul the aircraft into the air. As the aircraft continues to accelerate it will fly off in a slightly nose-high attitude and rapidly accelerate to the nominated climb speed.

Rotate generally refers to rotating the aircraft about its main wheel axles into a nose-high attitude to increase the angle of attack and lift the aircraft off the ground. Commonly this is done at a speed just above the stall speed (about 5 to 10 kts), hence rotate speed. The aim of this procedure is to minimise the retarding effects of the ground roll, and it is often used on soft surfaces or on runways of minimum length). There may, however, be an appreciable delay in accelerating to climb speed.

This briefing discusses the normal takeoff, but you may have to modify it for your conditions of runway length and surface (refer CFI).

On reaching the nominated climb speed, the climb attitude is selected, held and trimmed.

¹³¹ Hawkins, 1993

Climb Out

Each leg of the circuit is named and explained. The first leg – ***climb out*** – is the leg on which separation from other aircraft in the circuit is achieved. This is because the aircraft groundspeed is at a minimum while climbing into wind, and therefore the circuit pattern is minimally distorted. The practice of trying to provide adequate separation from aircraft ahead during the downwind leg where the groundspeed is at a maximum should be discouraged, as this tends to unnecessarily stretch out a busy circuit. Therefore, although a climbing turn onto crosswind **may** be started at **not less than 500 ft agl**, the actual height at which the turn is started will be dictated by traffic ahead. Where no conflict with traffic ahead is anticipated, the turn should be started **at 500 ft agl**; this will assist any following aircraft.

Crosswind

The crosswind leg is at 90 degrees to the climb out path and in the circuit direction. Before starting the turn, lookout is stressed and a reference point onto which to turn is chosen. Commonly, this is a point on the horizon off the wingtip. However, since the aim is to track over the ground at right angles to the runway, the reference point will need to be modified to allow for drift. Another method is to continue the turn until the trailing edge is almost parallel with the runway. How close to parallel will depend both on drift and on aircraft wing shape.

Downwind

The turn onto downwind is made at a suitable distance out, onto a suitable reference point so as to track parallel to the runway, and the aircraft is levelled at circuit altitude. This may require the aircraft to be levelled before, during or after the turn onto downwind. Lookout is again stressed, especially for aircraft joining the circuit on the downwind leg.

The downwind radio call is given at right angles to the upwind end of the runway to positively establish your position in the circuit for other traffic and Air Traffic Control (ATC) if applicable. As the downwind leg is quite long, if the radio call is delayed for any reason until abeam the threshold or later, the call should be, ***late downwind***. As a common courtesy, and to promote situational awareness of all traffic in the circuit, the downwind call should include your intentions, for example, full stop or touch-and-go. If your position in the circuit is advised by ATC, for example, “number three”, a visual search should be made to positively identify the positions of the appropriate number of aircraft ahead. This is generally achieved by scanning from the threshold back along the approach path and base leg, counting off aircraft sighted, ahead of you.

Checklists

The downwind checks, commonly BUMFPH or BUMFH are completed. The use of this mnemonic is **not necessarily** recommended.

The common practice of checking undercarriage in fixed undercarriage training aircraft, stems from a fear that one day in a retractable undercarriage aircraft the gear will be overlooked and left up. However, this argument may not be valid.

The attempt to standardise checklists across aircraft types may result in irrelevant checks becoming so automatic that they are not actually carried out when required¹³². In addition, most retractable gear type aircraft require the undercarriage to be extended **before** the brakes can be checked for pressure. So the mnemonic should be UBMFPH if it is to be of any use in later training. Thus the use of this standard mnemonic could be considered

¹³² Degani & Wiener, 1990, p.24

irrelevant for fixed-undercarriage types and generally wrong for retractable types, and its use could provide a latent error awaiting the right set of circumstances to trigger an accident¹³³. P for pitch is sometimes included and sometimes not, on the same grounds as the undercarriage argument. To be consistent, both items should be either in the checklist or left out.

Research¹³⁴ has shown that latent errors do exist within the normal checklist, and it is recommended that the normal checklist should be type specific and backed up by at least a written checklist (refer CFI).

Spacing

The correctness of the downwind spacing is assessed and noted for correction at the base turn and any drift allowed for. Weaving downwind in an effort to correct the spacing should be avoided. But the reference point may be altered to maintain a parallel track to the runway. In nil wind the DI should approximately indicate the reciprocal of the runway in use.

To judge spacing, a feature of the airframe is assessed against the runway; for example, in most low-wing aircraft the correct spacing is achieved when the wingtip runs down the centre line, as observed by the student. In the PA38, which has very long wings, the outboard flow strip is used, and in high wing aircraft the spacing is normally one third down the wing strut from the tie-down end. Based on these observations, the spacing is noted as correct, too close or too wide.

Base Turn

The turn onto base starts at approximately 45 degrees to the threshold. Lookout is emphasised and, commonly at this point, a reference point off the wingtip is chosen. Carb heat is selected, power reduced and a **level** turn started to bring the airspeed into the white arc. In the white arc, lift flap (10 to 20 degrees) is selected and, as the airspeed approaches the nominated descent speed, the correct descent attitude is selected, held and trimmed.

The above is the sequence that will be used in this guide, although the point at which the turn onto base is started may be varied as a result of the wind strength.

Some organisations prefer to wait until the turn onto base is complete before extending flap, so as to avoid pitch changes or an undetected asymmetric flap condition. If only one flap extends, the aircraft would tend to roll, and if the aircraft is entering a turn at the same time, the roll caused by this asymmetric condition may not be detected before an extreme angle of bank is reached. Although this possibility is remote, it may be a valid argument, depending on aircraft and flap type, as well as the amount of flap extended in the turn (refer CFI).

The other method of avoiding this situation is to begin reducing airspeed late downwind. Two areas need consideration if this method is to be used; firstly, the 45-degree turn point will need to be anticipated by an appropriate distance to avoid stretching the circuit, and secondly, this procedure may cause unexpected spacing problems for the aircraft behind. Therefore, this method is not generally recommended (refer CFI).

The power setting chosen at the base turn depends on the assessment of the downwind spacing (close, correct or wide) and the proximity to 45 degrees from the threshold when commencing the turn (early, correct, late). Commonly, 1500 rpm is used **as a guide**, and this is based on the correct spacing downwind and 45 degrees to the threshold. Any other condition will require a higher or lower power setting; for example, close downwind but correct at 45 degrees, try a lower power setting, say 1300 rpm.

¹³³ Reason, 1990

¹³⁴ carried out by Degani and Wiener (1990)

The turn is continued onto the reference point with an allowance for drift or until the leading edge of the wing or wing strut is parallel with the runway (allowing for drift).

Avoid using ground features as turning reference points as this may cause difficulty for the student at an unfamiliar aerodrome.

Base Leg

Normally, once established on base leg, additional flap is extended and the attitude adjusted to maintain the nominated descent airspeed.

Before the descending turn onto final, lookout is emphasised, especially along the approach path to ensure no other aircraft are on long final. The roll out onto final, or approach leg, must be anticipated so that the wings are level at the same time as the aircraft is aligned with the centre-line. Throughout the turn the angle of bank should be adjusted to achieve this by about 500 ft agl. The nominated descent airspeed should be maintained through attitude.

Final

When established on final, full flap is selected and the airspeed maintained, or allowed to decrease to approach (or threshold crossing) airspeed through attitude adjustment. (refer aircraft Flight Manual and CFI).

Because of the possibility of large flap deflections and the aircraft low altitude, extending flap during the turn onto final is avoided, for the asymmetric reasons given above.

The approach path is monitored by reference to the correct runway perspective. Throughout the descent the aiming point, commonly the runway numbers or threshold, is monitored and the power adjusted as required to maintain a steady rate of descent to touchdown – power controls the rate of descent¹³⁵. With the aircraft trimmed to maintain the required attitude (airspeed), if the aiming point moves up the windscreen, the aircraft is undershooting – increase power. If the aim point moves down the windscreen, the aircraft is overshooting – decrease power. If the aircraft **is** correctly trimmed the power adjustments will be quite small; these are described as a **trickle of power**.

On short final, carb heat is selected cold when a landing is assured, in anticipation of any requirement for full power.

Landing

As previously noted, the landing, although it will have been observed and possibly followed through before this lesson, is the new material being introduced on which the emphasis should be placed.

The landing is carried out in two distinct phases, the **round-out** and the **hold-off**. The combination of these two phases is termed the **flare**.

The round-out, with the objective of flying parallel with the ground, begins at a suitable altitude for the aircraft speed. For a normal approach this is described as about 50 ft.

When the landing is assured, often pattered as **crossing the fence**, the throttle is closed, and at about 50 ft the level attitude is smoothly selected – the round-out. As the airspeed decreases the aircraft will start to sink. The sink is observed by looking **outside** at the far end of the runway (or horizon) and is the point where the second phase of the landing process begins. The most common errors made by students during the round-out is not looking far enough ahead and lowering the nose in an attempt to fly down to the ground.

¹³⁵ Campbell, 1994, p.13-19

The hold-off involves a gradual increase in backpressure to control the rate of sink and to achieve the correct attitude so that the touchdown is light and on the main wheels only. During this phase the student's focus is gradually shortened to facilitate depth perception and provide cues about the sink rate until, at touchdown, the point of focus is just ahead and slightly left of the aircraft nose.

The nosewheel should be gently lowered with elevator by relaxing the backpressure before the wings stall, dropping the nose onto the runway.

Keep straight on the runway centre line by reference to a point at the far end of the runway, and apply brakes **as required**.

Airborne Sequence

Taxi

The student should be capable of taxiing to the appropriate holding point and completing all or most of the necessary checks. As the considerations behind the takeoff safety (or emergency) brief may not have been fully explained yet, you may need to complete this briefing for the student.

On lining up, the aircraft should be allowed to roll forward a short distance on the centre line to ensure the nosewheel is straight, on a distant reference point.

Once on the runway the aircraft is held on the foot brakes (if required), **never** on the park brake. This is because, when taxiing, forgetting to release the park brake is easily and rapidly identified. However, with the application of full power for takeoff, the poor acceleration may not be recognised early.

In older aircraft, fitted only with a hand-operated brake, if brake is applied once on the runway, the hand applying it should not be removed until the start of the takeoff roll.

Takeoff

During the takeoff roll, ensure that no brake can inadvertently be applied. This is commonly pattered as **heels on the floor**. If the student's heels are on the floor it is not possible to reach the brakes. Early in the takeoff roll, with full power applied, temperatures, pressures, rpm and airspeed should be checked for normal readings.

Climb Out

During the climb out and at a safe height, **not less than** 300 ft agl, the after takeoff checks are completed and a check made (glance back) on whether the chosen high reference point is maintaining the aircraft on a straight track over the ground along the centre-line. If not, an adjustment to the chosen reference point is made.

Generally, the normal takeoff is carried out **without** flap extended (refer aircraft Flight Manual) and that has been the assumption of this briefing. If flap is used, retraction heights and speeds need to be discussed.

At night, looking back to ensure the centre line is being tracked is not carried out - runway heading (DI) is maintained to avoid spatial disorientation.

Downwind

On the downwind leg, although the physical eye height of students will vary, the effect on the judgement of spacing will be negligible. However, your perspective from the righthand seat may be noticeably different and must be compensated for, as it is what the student sees that is important.

In high-wing aircraft the judgement of one third down the strut **can** be difficult for the student, and there **may** be some value in marking the strut with tape or a felt-tip pen at the approximate position on the strut through which the runway should cut.

Base Turn

At the base turn, to enhance situational awareness, the student should be encouraged to estimate what power setting they would require, from wherever the base turn starts, to take them to the threshold in a steady descent without any changes. **This does not mean that the power setting should not be altered if required.**

During the approach, as with all phases of flight where the intent is to maintain a specific airspeed, it is important to emphasize that the correct **attitude** should be selected, held and trimmed. Attitude controls the airspeed¹³⁶.

You **must not** refer to controlling the airspeed with elevator, ie, by omitting attitude, as the student will likely comply with your instructions literally. This results in large attitude changes as the student, watching the airspeed indicator, attempts to hold the speed constant through elevator movements.

After Landing

The after landing checks are normally completed clear of the runway.

Under ideal conditions, during the student's introduction to the circuit, each circuit is flown to a full stop and the aircraft taxied to the holding point for another takeoff. Therefore, the considerations of a touch-and-go and the go-around are deferred to the next circuit lesson - circuit considerations.

Although including the go-around in this briefing can generally be deferred it is not always convenient, in a busy circuit, to carry out full stop landings. Therefore, a brief discussion on the touch-and-go procedure may need to be included in this briefing (refer CFI).

Should a go-around be required during this introductory exercise, it is recommended that you take control and pattern the procedure.

¹³⁶ Campbell, 1994, p.13-19

CIRCUIT INTRODUCTION

AIR EXERCISE:

1. Takeoff, Line up Checks
Reference Points
After takeoff checks
SEPARATION
3. Check track & Lookout
4. Call D/W (touch & go etc)
5. Downwind checks
6. Check & note spacing
7. Base Turn
Carb. Heat **Hot**
Power to _____
Level turn
White Arc - Flap
Attitude for _____kts
8. On Base
Check track
Flap as required
Attitude for _____kts
9. Anticipate - centre line
- 500' AGL
Attitude
- Maintain _____kts
Power
- As required (ROD)
10. On Final - Full flap - attitude for _____kts - Power for ROD - Carb. Ht Cold

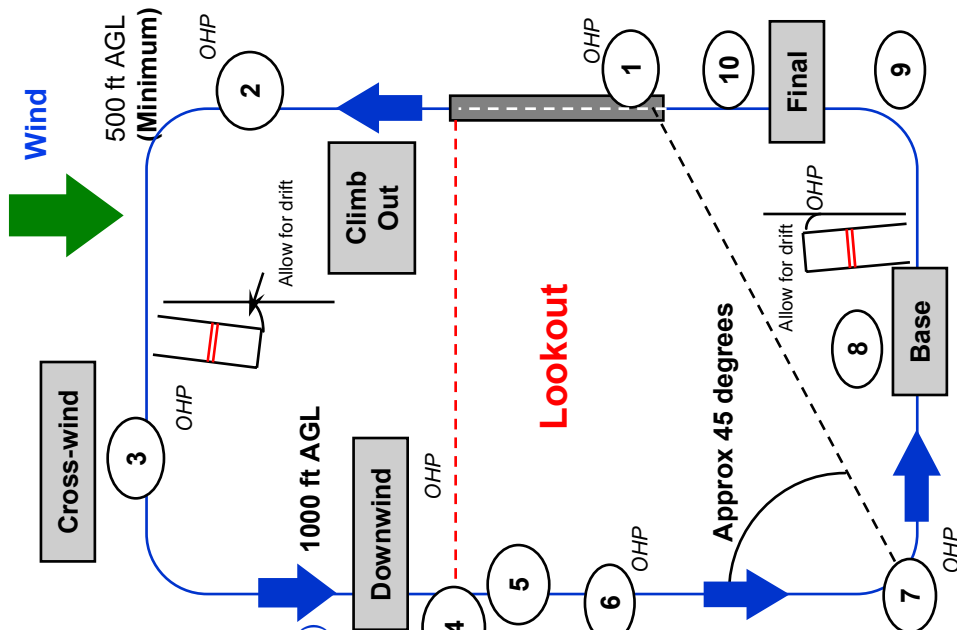

Landing: a) Round Out

- Power off
- Level off
- Transfer sight from aim pt to look well ahead at ref. point

b) Hold Off

- Adjust BP to control sink rate
- Land on main wheels
- Gently lower nose wheel
- Maintain centreline
- Brakes as required



OBJECTIVE:

To fly an orderly pattern around the aerodrome circuit in accordance with NZAIP procedures using the most suitable runway.

CONSIDERATIONS:

Takeoff

1. Swing on T/O (if relevant, refer CFI) - OHP Recommended
Slipstream (L) - Torque (L)
Keep straight on ref. Pt
2. Wind - Crosswind - A/C tends to weathercock
- Headwind - Shorter ground roll
- Steeper angle of climb
- Better obstacle clearance
- Tailwind - greatly increased ground roll, shallow climb
3. Power - use FULL power for all takeoffs

Landing

1. Into wind - Shorter ground roll
- Steeper descent angle
- Better obstacle clearance
2. Flap - Increased Lift \rightarrow Vs and \rightarrow landing speed
= Shorter ground roll
- Increased Drag gives lower nose attitude for same A/S
= Steeper approach better forward visibility & obstacle clearance
3. Power - Controls ROD (improves elevator/rudder effectiveness)

AIRCRAFT MANAGEMENT:

Right Of Way Rules (ROW)

- A/C landing have ROW over A/C taking off
- A/C in circuit have ROW over A/C joining
- Follow at a safe distance do not overtake or cut in front of other A/C
- All turns in circuit direction
- Circuit height 1000' AGL (unless otherwise stated in the VFG)

HUMAN FACTORS:

- Disorientation** - Situational awareness
 - Lookout & Listenout
 - Pre-flight preparation (VFG, W/V)
- Vision** - Landing cues
- Runway perspective
- Information Processing**
 - Mnemonics
 - Checklists
 - Plateau
- Stress** - Overlearning, Visualisation

Circuit – Considerations

This briefing is carried out before the second circuit lesson. It deals primarily with those aspects of a normal circuit that were deferred during the circuit introduction so as to avoid student overload. In addition, many of the terms that may arise during circuit training are explained to prevent confusion occurring during the first or subsequent solos.

Introduction

Test for situational awareness – Which runway is in use and why?

This pre-flight briefing is to acquaint you with the meaning of various terms, which may arise in the circuit and the procedures that they call for.

Objectives

1. To use the terms and procedures employed when a **deviation** from the normal circuit is required.
2. To revise circuits using the ***touch-and-go*** procedure (if applicable).
3. To revise circuits and carry out the ***go-around*** procedure.

Considerations

Touch-and-Go

The touch-and-go refers to a normal landing followed by a normal takeoff without stopping or braking. This procedure allows more circuits and landings to be practised in the same time, rather than stopping and taxiing back to the holding point; it is most common in a busy circuit.

This procedure is carried out **only** on runways of **more than adequate length** assuming the aircraft has touched down in approximately the correct place, ie, threshold or numbers area.

Go-Around

At **any time** after the approach starts the pilot may elect – or be instructed by ATC – to “go-around” (the old term was “overshoot”).

Since no landing will now be made off this approach, the aircraft will be flown over the runway, and another circuit will be carried out, to position again for a landing. The various legs of the circuit are still flown, from climb out to circuit altitude, downwind, base and finals.

Emphasise to the student that “going around” **does not** mean turning in a circle through 360 degrees.

Orbit

The orbit is a procedure used by ATC to improve separation from aircraft ahead. An orbit is most commonly carried out on the downwind leg and consists of a 360-degree medium level turn, that positions the aircraft back into the downwind leg, at about the same place, and about 1 minute later.

As the first half of the turn is completed a conflict with traffic approaching head-on is a real possibility and therefore a good lookout is essential.

An orbit on final or base (with flap extended) should be avoided. The go-around procedure is preferred because it is specifically taught before first solo, whereas low-level turns with flap extended are not.

Where applicable, the CFI should liaise with ATC on the preferred procedure.

Extend Downwind

Extending downwind is another procedure used by ATC and pilots to improve separation on aircraft in the circuit ahead or joining long final. The aircraft is flown on the reference point, parallel to the runway, for a suitable distance past the 45-degree base turn point, to achieve separation. The power setting selected at the extended base turn point will need to be higher, and a delay to both flap extension and descent may be required to regain the normal approach profile.

Dumb-Bell Turn

Fortunately the dumb-bell turn is a fairly rare occurrence. It is used by ATC when a change in wind direction makes it advisable to change the landing direction by 180 degrees. On completion of the turn, the aircraft is repositioned onto final for landing. If a dumb-bell turn is required, the takeoff is continued to a safe height (500 ft agl **minimum**) and a level turn is started in the opposite direction to the old circuit direction. Then the turn is reversed until an intercept on the final approach path can be made. Established on final, the approach starts, although an overshoot or go-around could also be started to re-establish the circuit. Clearly, the amount of time available to prepare for the landing will depend on what height and how far out the initial climb is continued to.

No professional instructor would authorise early solo circuit practice when there is any likelihood of these conditions occurring. Likewise, no professional air traffic controller would request a student on first solo to carry out this procedure.

Repositioning

Repositioning may occur on any leg of the circuit, but it is more commonly at ATC request than at the pilot's request. Most commonly, this occurs on final where parallel runways are in use. Of two aircraft on final for the one runway the latter, because the aircraft landing ahead has right of way, is asked by ATC or requests to reposition onto final for a landing on the parallel runway to maintain adequate separation.

Repositioning may also be used in the event of a change in the wind direction rather than the dumb-bell turn. Commonly, the aircraft is flown to the middle of the old downwind leg and then a 180-degree level turn made to position the aircraft on the new downwind leg and the approach begun as normal. For less dramatic runway direction changes, the heading need only be adjusted to achieve a parallel track to the new runway in use.

This is the preferred method, over the dumb-bell turn, of repositioning where a change in wind direction makes a runway change advisable.

Low Level

The low-level circuit is carried out at less than 1000 ft agl (or the promulgated circuit height), normally at 500 ft agl. It is most commonly used by instructors, but it may be requested by the pilot or ATC. Only the briefest explanation of this term is included in this briefing for the reasons given in the notes below. The decision to include more or less should be referred to the CFI.

The low-level circuit is generally used by instructors to quickly position the aircraft for the last part of the approach and landing so that the student can practice more landings. However, its general use is not recommended as all other legs of the circuit are either so rushed that the student has little opportunity to prepare for the landing, or are flown by you, providing the student with little opportunity to practice the other flight phases.

The low-level circuit **does not** provide an automatic right of way.

The practical application of the low-level circuit will be discussed and practised in precautionary landings. The need to teach low-level circuits before first solo should not arise (refer CFI).

Wind Gradient

Wind gradient is the gradual decrease of the wind speed near the ground, due to surface friction and the air's viscosity¹³⁷.

Windshear

Windshear is a **sudden** change in wind speed **or** direction, most common in winds above 10 kts, and it is a hazard at low altitude.

A sudden change in wind speed or direction can result in a sudden loss of airspeed and, due to aircraft inertia, a rapid sink.

The correct response is to apply power to arrest the sink and adjust the attitude to maintain the airspeed.

Where windshear is encountered unexpectedly a go-around may be appropriate.

Where conditions of possible windshear (or gusts) are reported or suspected, it is recommended that the approach and threshold speeds are increased. For example, if the approach speed is increased by 5 kts and a sudden change of wind strength results in a decrease of 5 kts in indicated airspeed, the actual approach speed would still be correct.

The decision to continue the approach at an increased approach and threshold speed must take into account available runway length.

Wake Turbulence

Wake turbulence is a reasonably complex subject and can be dealt with only superficially in this briefing. You may prefer to make this the subject of a separate pre-flight briefing before the next circuit revision (refer CFI).

Wake turbulence is the result of disturbed air left behind an aircraft, partly from either propeller slipstream or jet blast, but mainly from the production of lift. It is encountered when following too closely behind another aircraft, especially a heavier one, and is worst when that aircraft is at high angles of attack during takeoff or landing.

During the production of lift, air spirals off the wingtips in vortices that increase in size behind the wing, sink, drift downwind, and **gradually** dissipate.

This turbulence can induce a roll in the following aircraft that control forces **cannot** counter, and therefore it is **extremely** dangerous.

Wake turbulence is avoided while taxiing by allowing adequate separation for propeller or jet blast.

Jet aircraft always have their rotating beacon on when an engine is running.

Before takeoff, allow adequate separation between yourself and heavier aircraft ahead (up to 3 minutes in nil wind).

During the approach, avoid getting close behind, downwind or below heavier aircraft. For example, if there is a crosswind, fly the final approach slightly upwind of the previous aircraft or **preferably** fly above its approach path and descend more steeply.

¹³⁷ Kermode, 1996

Land past the point of touchdown of the preceding heavier aircraft; as its nosewheel touches down there is no more lift being produced.

Consider runway length available; an early go-around may be more appropriate.

Aircraft Management

Throughout circuit training you should continue to place more and more emphasis on the student's command decision-making. The ***pilot's priority sequence*** for enhancing decision-making **whenever** a deviation from the expected occurs should be forcefully stated.

AVIATE — NAVIGATE — COMMUNICATE

The responsibilities of the pilot-in-command should be discussed with reference to ATC clearances or requests. **Every** clearance or instruction issued by ATC **must** be accepted by the pilot-in-command **before** it is acted upon. The student should be encouraged to consider the probable outcome of complying with each clearance or instruction, giving due regard to their own capabilities and that of the aircraft, **before accepting** the clearance or instruction.

Where the student considers the clearance or instruction to be unacceptable, the student **must** be encouraged to assert their pilot-in-command responsibility.

The most common mistake in attempting to comply with an ATC request or instruction comes from accepting a clearance to land on an unsuitable runway.

As in all other aspects of aviation, good aviation practice or common sense is a major factor in the acceptance or rejection of ATC clearances or requests. The pilot-in-command has responsibility for the safety of the aircraft, passengers and crew – but not a right to be obstructive. The clearance, instruction or request should be complied with if, after due consideration, no adverse outcome as a result of complying with the clearance, instruction or request can be foreseen. If the pilot-in-command believes that the safety of the aircraft may be compromised, then clarification of the clearance, instruction or request should be sought from ATC, an alternative suggested by the pilot-in-command, or the clearance, instruction or request refused.

The student should be fully aware that once a clearance has been accepted, it must be complied with (unless a change to the clearance is negotiated, or the pilot-in-command is reacting to an emergency) and that no matter what the clearance, instruction or request and who issued it, the pilot-in-command is **solely responsible** for the safety of the aircraft, passengers and crew.

This may be a good time to remind the student that although you will allow them to make as many command decisions as possible, you are the pilot-in-command.

The requirements for VFR inside a control zone should be revised and the conditions that require a ***Special VFR*** (SVFR) clearance introduced.

It is the responsibility of the pilot-in-command to **request** a SVFR clearance **before** any of the parameters for maintaining VFR in controlled airspace cannot be complied with.

Human Factors

Disorientation and **I**nformation processing (ADVISE mnemonic), in relation to situational awareness, continue to be of prime importance throughout circuit training. **S**tress, often self

imposed through trying to comply with every ATC request without due consideration, is reduced through familiarisation with the aircraft and the various procedures combined with good prioritising – **aviate, navigate, communicate**.

Air Exercise

The air exercise discusses the procedures to be used for a touch-and-go (if applicable) and a go-around.

Touch-and-Go

Once the nosewheel has been lowered to the runway, the flap are raised to the normal takeoff position and full power applied for another takeoff. The weight is taken off the nosewheel with elevator, and the aircraft is allowed to fly off.

Go-Around

Carb heat is selected cold and full power applied. Raise the nose to the level attitude, or slightly above, and reduce the flap setting (as appropriate to aircraft type) immediately.

If flap has been extended and the aircraft trimmed for the descent attitude, there may be a very strong pitch up when power is applied. The student must be made aware of this and be prepared to prevent the nose pitching above the level attitude. In addition, do not hesitate to raise flap as described above as soon as full power has been applied and the attitude adjusted, accelerating over the runway rather than amongst obstacles in the climb-out area.

As the aircraft accelerates the attitude is adjusted so that the nose is on the horizon. At a safe height (refer CFI), and safe airspeed (through ___ kts), with a positive rate of climb, the remaining flap is raised gradually and the aircraft allowed to accelerate to the climb speed. Climb to circuit altitude.

Regardless of when circuit altitude is reached, the aircraft should be flown upwind along the climb-out path to the normal crosswind turn point. Turning crosswind early will shorten the downwind leg and may rush the student's preparation for the approach. Any decision to turn early must consider other traffic in the circuit and must have ATC approval.

During the go-around, flying over the runway would mean flying over any aircraft taking off. The normal procedure, therefore, is to fly just to the right of the runway, so that the pilot has the runway on the left and can observe traffic on the runway or climbing out. This procedure, as with many other general rules in aviation, needs to be tempered with good aviation practice. Where parallel runways are in use, flying to the side of the runway **may** conflict with traffic landing or taking off on the parallel runway (refer CFI). In this case it may be better to fly along the opposite side, or if it is **known** that no aircraft are taking off on the runway ahead, to maintain runway heading. If the go-around is begun on short final or later, the aircraft is not flown to one side of the runway during the climb out, because it is known there is no traffic ahead or below that might conflict.

With the aircraft established in the normal climb and trimmed, it may be necessary to advise ATC that you are "going around".

Airborne Sequence

The touch-and-go should be a simple and logical extension of the landing roll.

The go-around is initially started at a safe height, once established on final. Ideally, subsequent practice reduces the height at which the go-around starts. Circumstances, however, may not permit this gradual introduction to the go-around.

Throughout the procedure you should emphasize the correct priority for dealing with the unexpected – **aviate – navigate – communicate**.

The student should be made aware that this is a normal procedure, **not** an emergency. The student should be encouraged to carry out a go-around (and be praised for doing so) at any time throughout the approach to touchdown, if they are not confident about any aspect or parameter of the approach or landing.

The other procedures described under considerations (other than low level, which is discussed in precautionary landing briefing) are demonstrated and patterned when they occur.

CIRCUIT - CONSIDERATIONS

OBJECTIVES:

1. To use the terms & procedures for deviating from the 'normal' circuit.
2. To revise circuits using the 'touch and go' procedure (if applicable).
3. To revise circuits and carry out the go-around procedure.

CONSIDERATIONS:

1. **Touch and Go** - runways of more than adequate length
2. **Go-Around**
 - Reasons for a go around**
 - Runway length inadequate
 - Bounced landing
 - Landing path blocked
 - Pilot discretion
 - Approach too high or too fast
 - ATC instructed
 - Wind direction change
 - Too close to A/C ahead
3. **Orbit** - 360 degree medium level turn
4. **Extend Downwind** - to improve separation, adjust base turn and power as needed
5. **Dumb-Bell Turn** - used to reposition for landing on runway of T/O - **AVOID**
6. **Repositioning** - preferred method of runway change
7. **Low Level** - 500' AGL circuit
8. **Wind Gradient** - gradual change of wind speed due to surface friction
9. **Wind Shear**
 - **sudden** change of wind speed or direction
 - increase approach and threshold speed
 - arrest sink with positive power increase
 - maintain airspeed with (lower) attitude
10. **Wake Turbulence** - slipstream and vortices



AIR EXERCISE:

1. **Touch & Go** (if applicable)
 - After touchdown** (lower nose wheel)
 - Raise flaps to takeoff setting
 - Apply full power (keep straight)
 - Normal take-off
2. **Go-Around**
 - Carb heat Cold - Full power **BEWARE PITCH UP**
 - Nose to level flight attitude
 - Reduce from full flap setting (as appropriate for A/C type)
 - positive acceleration
 - Raise nose to horizon - safe height (obstacles)
 - safe speed (through ___ kts)
 - positive ROC
 - Raise remaining flap gradually
 - At ___ kts select climb attitude (example 70 kts) - Trim
 - Advise ATC/ traffic " --- going around"
 - Keep runway in sight but remain clear of traffic
 - Request early turn (if required) back into circuit

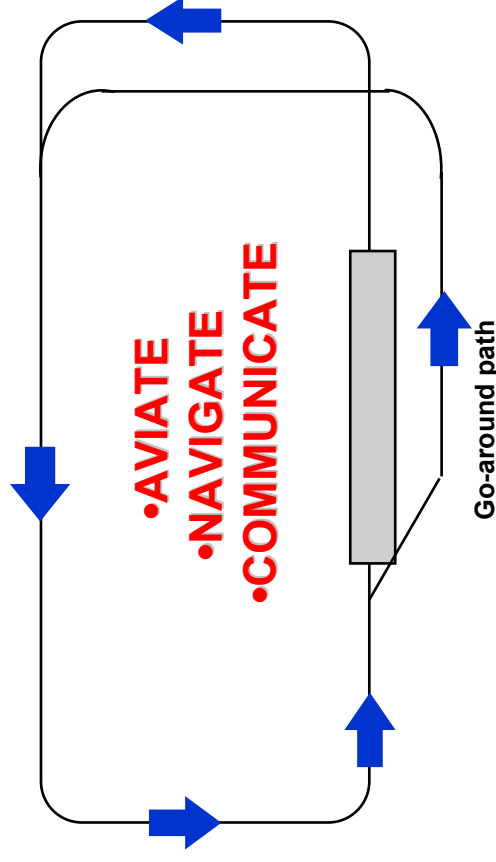

AIRCRAFT MANAGEMENT:

Aviate - Navigate - Communicate

ATC Clearances & Requests

VFR and SVFR

HUMAN FACTORS:

Situational awareness

- Lookout & listenout
- Traffic awareness
- Prioritise
- Command decision making

Stress

Engine Failure After Takeoff

Although this briefing is headed EFATO, it will discuss engine failure both during **and** after takeoff.

The difference between a forced landing and EFATO is the time available. More height = more time available. For example, an engine failure while low flying would require the same initial actions as an EFATO. Below 1000 ft agl, it is recommended the EFATO procedure be adopted, and above this height, time may permit another course of action to be considered.

1000 ft is a guide. As with any emergency procedure, the pilot-in-command will decide the appropriate action.

As with all emergency procedures training, you simulate the emergency without endangering the aircraft or the crew.

You must keep in mind the objective of the lesson, to learn a procedure – **not to prove** survival.

The procedure being taught is the one that has been shown, statistically, to give the best chance of survival. It does not guarantee survival, so there is no point in continuing the exercise past the point of a procedural response, merely to show that the aircraft could actually land. Likewise, there is no value in turning off the fuel or moving the mixture into ICO at low altitude, merely to make the experience more real. Suppose you wanted to train the student to respond with a procedure that has been shown to be the best response to a cabin fire; setting fire to the cabin and seeing how long it takes the student to put out the fire would **not** be the recommended method!

Introduction

Although engine failure in modern aircraft is quite rare, the takeoff phase incorporates all the worst aspects of this type of emergency. The aircraft is usually heavy, slow, low and in a nose-high attitude. These factors combine to provide the least amount of time – and therefore height – available to respond to the emergency.

Considerable time is spent on overlearning a procedure to adopt in case it ever does happen. The purpose of overlearning is to produce an automatic response that best utilises the time available, by overcoming the initial surprise or shock and enhancing the decision-making process.

“I will simulate the engine failure after takeoff by partially closing the throttle. You are to assume that any partial power reduction by me during the climb out is a total power failure simulation. During the simulations, power will always be available, should we need it.”

Objective

To adopt the recommended procedure in the event of an engine failure at low level (below 1000 ft agl).

Considerations

Common Causes and their Prevention

The modern aero-engine is a fairly simple, slow revving (2500 rpm versus average car 4500 rpm) four-stroke engine, and therefore it is very reliable. Its operation requires the mixing of air and fuel and the introduction of a spark. The result is quite predictable. Generally, the reasons why aero-engines sometimes stop can be traced to the lack of one of these components¹³⁸.

Fuel Contamination

The most probable cause of engine failure is fuel contamination, ie, something in the fuel – most commonly water¹³⁹.

Most students are surprised to learn that mechanical failure is not the most common cause.

The risk of fuel contamination is minimised through fuel sample inspection during the pre-flight and after-refuelling checks, as well as the pre-takeoff engine run-up. The fuel sample should be examined for foreign objects, colour and smell.

Early in the student's training, it's a good idea to add some water to a fuel sample so that the student can clearly see what it looks like when mixed with fuel.

Fuel Starvation

Definition: Fuel on board but not feeding to the engine.

The most common cause of fuel starvation results from the pilot selecting the wrong fuel tank or placing the fuel selector in the OFF position. Other less common but possible causes are engine-driven fuel pump failure or blocked fuel lines, injectors or fuel vents.

Blocked fuel vents create the added danger of wing collapse, as fuel sucked from the wing tanks by the engine-driven fuel pump creates a vacuum.

The risk of fuel starvation is minimised through systems management familiarity, the engine run-up, and the use of mnemonics or preferably written checklists to carry out the ***Drill of Vital Actions (DVAs)***.

Fuel Exhaustion

Definition: No useable fuel on board the aircraft.

The most common cause of fuel exhaustion is poor in-flight decision-making – simply running out of fuel. Another cause is leaving the fuel caps off, allowing fuel to be sucked out by the low-pressure area over the wing top surface.

Fuel exhaustion is avoided through situational awareness and careful pre-flight planning, as well as the pre-flight inspection.

Carburettor Ice

In conditions of high humidity, carb ice can form during taxiing and may be hard to detect at low power settings.

The risk of carb ice is minimised through the pre-flight engine run-up. In conditions of suspected carburettor icing, after prolonged idling, it may be advisable to cycle the carb heat just before takeoff.

¹³⁸ NZ Flight Safety, 1989

¹³⁹ refer NZ Flight Safety, 1987

Because of the adverse affects of carb heat on power output, and the limitations of the short-term memory, if this practice is encouraged, then the hand moving the carb heat control should not be removed until the carb heat control is returned to cold.

Air Blockage

Another possible cause of the air supply being obstructed is a blockage in the carburettor air filter. In this situation, the carb heat, which bypasses the air filter, may provide an alternate source of air to the carburettor. The risk of filter blockage is minimised through careful examination of the air intake during the pre-flight inspection.

Spark

During takeoff the engine is working at its hardest and, although mechanical failure is still the least likely cause, the risk of mechanical failure is increased.

Statistically, the first reduction in power after takeoff is the most common time for a mechanical failure to occur. Therefore, if a reduced power setting is to be used for the climb, full power is maintained to a safe height, the aircraft cleaned up and established in the climb before power reduction.

The risk of mechanical failure can be minimised by completion of a thorough pre-flight inspection and engine run-up.

The Aborted Takeoff

Early in the takeoff roll, temperatures, pressures, rpm and airspeed are quickly scanned for normal readings. If anything about the takeoff roll appears abnormal, or something blocks the runway, or if ATC requests, the takeoff should be abandoned, also called **aborted**.

EFATO

Aviate

Because the aircraft is slow, low and in a nose-high attitude, an engine failure at low altitude provides little time for decision-making. Therefore, the first response – **aviate** – must be a positive and automatic movement to lower the nose and close the throttle.

Navigate

The second response – **navigate** – involves turning into wind (if applicable or necessary) and choosing a suitable landing site within easy reach.

Landing Site Considerations

The choice of landing sites will be limited by the height and therefore time available, but there is one sure way to improve your options – always use full runway length. Runway behind you is useless. From full length an engine failure at low altitude may present you with the perfect forced landing area, ie, the runway ahead.

The prime criterion applied to the selection of a suitable landing site is to avoid major obstacles so as to **keep the cabin intact**.

Common practice is to limit the choice of landing site to X degrees either side of the nose; a simpler and more realistic choice may be to choose anything in the windscreen. This could result in a turn of between 60 and 90 degrees at the most and a crosswind landing.

Do not attempt to turn back to the runway.

Not only is the rate of descent and stall speed increased in the turn, but also any turn past 90 degrees (assuming an into-wind takeoff) will result in a tailwind and increased groundspeed on landing.

Various articles should be included in the handout describing the statistical analyses and inadvisability of attempting to turn back to the runway¹⁴⁰.

Takeoff Safety Brief

Because the time available for decision-making is short, the anticipated response to an engine failure is briefed before line up where time is plentiful.

This type of pre-takeoff preparation is common in multi-engine aeroplanes and, although the choices in a single-engine aircraft are limited, its use is highly recommended. Verbally or mentally preparing a response, through visualisation before an unexpected emergency, has been shown to increase greatly the chances of success in the correct execution of the desired response.

Although the takeoff safety briefing may have been introduced in earlier lessons its use is fully explained here.

Also note that, although it is common practice to brief verbally in training situations, this briefing is not necessarily carried out **verbally** when carrying passengers.

The takeoff safety brief should include the intentions of the pilot-in-command in the event of an engine failure during the takeoff roll and after takeoff.

The verbal briefing for engine failure during the takeoff roll need only be a reminder to close the throttle and use brakes as required.

The verbal brief for engine failure after takeoff includes the critical action of lowering the nose (**aviate**) and the plan of action based on consideration of the current conditions (**navigate**).

To improve situational awareness, the student should be encouraged to consider the direction of the wind in relation to the runway in use. If the wind is not directly down the runway but slightly across, then if an engine failure after takeoff occurs, a gentle turn into wind would result in increased headwind and a shorter landing roll.

The type of terrain off the end of the runway should be visualised and suitable landing areas recalled from memory of earlier flights off this runway.

Aircraft Management

Since aircraft systems management errors are often the root cause of in-flight emergencies¹⁴¹, consideration must be given to aircraft systems management, regardless of how simple those systems appear. The use of schematics or models to describe the aircraft fuel system is encouraged, as well as the use of handouts. In addition, the student should be permitted to operate the fuel cocks, actually turning the fuel off and on, during the pre-flight check.

There is little point in making the perfect forced landing only to be hit in the head by some heavy loose article, therefore, the pre-flight inspection also includes securing or removing loose articles, for example, a briefcase, a first aid kit.

So that there is no confusion between the simulated engine failure and an actual occurrence the student should be advised that you will partially close the throttle and use the word “simulating”. Any partial power reduction by you during the takeoff, is to be considered by the student as a total failure.

¹⁴⁰ There are plenty of examples in Flight Safety and Vector Magazine

¹⁴¹ NZ Flight Safety, 1986

Any checks that would be carried out in the event of an actual engine failure, that are recommended not to be carried out during the simulation, are known as **touch checks**. These will be written in red on the whiteboard, under air exercise. A touch check requires the student to state the check verbally and touch the appropriate control, preferably with only one finger, but not perform the required action.

The simulation is ended with the instruction “go-around”, at which point the student is to immediately carry out a go-around.

As large throttle movements will be made close to the ground, smooth throttle movements, to avoid a rich cut, should be revised.

The go-around should start at not less than 300 ft agl (refer CFI). There will be occasions when environmental considerations, eg, noise, will dictate go-around from a higher level. The first demonstration/patter and student practice should be conducted at a suitable height so as to reduce the student’s stress and to aid information processing.

The student should be advised that this exercise is **never** to be practised solo.

At controlled airfields, ATC must be advised of the intention to carry out a simulated engine failure after takeoff and advised when the simulation is complete. The student should be advised that these calls will be made by you.

EFATO simulations are not to be carried out when below 300 ft agl, nor with passengers on board, nor when following traffic may conflict.

Human Factors

Minimising **D**isorientation through situational awareness, facilitating **I**nformation processing through the use of checklists, mnemonics and careful pre-flight planning, as well as reducing **S**tress through overlearning (ADVISE mnemonic) are all features of this exercise. In addition, the concepts of Aeronautical Decision-Making (ADM) are introduced through varying the height at which the simulation is started, permitting a wider or narrower range of options.

Air Exercise

The exercise starts with the considerations of the takeoff safety brief.

Aborted Takeoff

The actions are the same for an engine failure on takeoff as they are for the aborted takeoff.

Aviate. Close the throttle.

Navigate. Keep straight and use brakes as required; backpressure is used as required to keep the aircraft weight off the nosewheel.

Caution: Do not stop braking when elevator is applied as the aircraft may lift off. As braking is decreased aft elevator is decreased.

Communicate. Advise ATC (if applicable).

If an over-run appears likely – FMI – Fuel OFF, Mixture IDLE CUT-OFF and Ignition OFF.

Keep the cabin intact. Don’t run the aircraft nose into fence posts, steer between them.

Consider a turn to reduce forward momentum.

In nosewheel aircraft, the centre of gravity is ahead of the main wheels and a natural directional stability results, so the turning force – full rudder and corresponding full brake, nosewheel steering if fitted – has to be maintained to sustain the turn. As a turn of only 90 degrees may be achieved, the direction of turn should consider obstacles.

In tailwheel aircraft, with the centre of gravity behind the main wheels, there is a tendency for a turn, once started, to tighten up. This is called a ground-loop, and it usually results in a rapid U-turn around one main wheel. The manoeuvre is easily initiated (often unintentionally) with sufficient brake and or rudder on one side.

Neither turns nor ground-loops are actually practised in either type. Also, seat-belts are not **specifically** designed to counter sideways loads, so the advisability of this manoeuvre in an emergency should be discussed with your CFI and supervisor.

EFATO

Aviate. Lower the nose – close the throttle.

The airspeed achieved is not important at this time, as **any** nose-low attitude will avoid the stall. The throttle is closed because a temporary surge in power may divert the student and cause indecision.

Navigate. Follow the takeoff safety brief and choose a landing site from anything in the windscreen, within easy reach, and clear of **major** obstacles so as to keep the cabin intact. Use flap as required to reach the landing site.

The priorities of the pilot-in-command should focus on landing into wind and keeping the cabin intact. However, **IF TIME PERMITS** the attitude can be adjusted for best glide, carb heat applied, and the **trouble checks** (FMI) carried out.

Although the possibility of ice stopping the engine during the takeoff is remote, and the formation of ice during the limited time for which the exercise is continued is unlikely, selecting carb heat to hot provides an immediate alternate source of air to the carburettor, should the air filter have become blocked during the takeoff.

Since fuel is the most common cause of engine failure, it appears early in the emergency checklist. **F**uel pump ON, change tanks (touch). **M**ixture RICH, primer LOCKED, **I**gnition on BOTH (touch) and check for power (touch).

Assuming no response, or if time does not permit completion of the trouble checks, the **shutdown checks** are completed to minimise fire risk. Fuel OFF (touch), mixture IDLE CUT-OFF (touch) and ignition OFF (touch).

Communicate. Transmit MAYDAY (touch) and when full flap has been selected, master OFF (touch).

The Mayday transmission from low level may have limited value at an uncontrolled aerodrome, as would the selection of 7700 on the transponder. At a controlled aerodrome, the takeoff is **usually** monitored by ATC and only an abbreviated call should be required, for example, “MAYDAY”, aircraft registration, “engine failure”.

You will need to emphasise that proper attention to all pre-flight preparation will minimise the risk of engine failure on takeoff and that the initial actions **aviate, navigate** greatly increase the chances of survival. The emergency checks and drills are unlikely to improve the chances of survival significantly and are only carried out **if time permits**.

This sequence may be presented in the form of a flow chart.

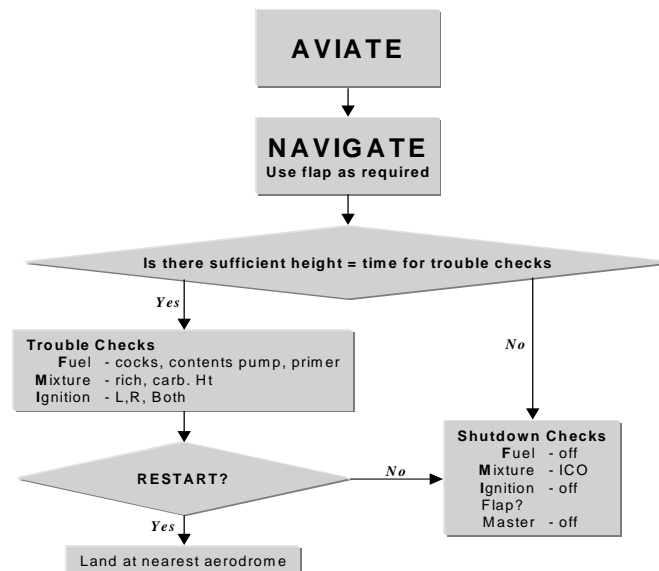

Airborne Sequence

If runway length is suitable and traffic permits, an aborted takeoff is carried out. This **may** be simulated soon after full power is achieved, by advising the student, for example, that oil pressure is (simulated) zero. Commonly the aborted takeoff is neither demonstrated nor patterned. The reason for abandoning the takeoff is simulated by you and the student is talked through the actions. The decision to demonstrate, pattern or talk through depends on your assessment of the individual student's ability.

Engine failure **during** takeoff (early in the takeoff roll) is simulated by you, by pulling the mixture control to IDLE CUT-OFF. The advantage of this method is it allows the student to take the correct action of closing the throttle.

Don't forget to select mixture RICH once the throttle has been completely closed.

Engine failure **after** takeoff follows the standard airborne sequence and is always simulated in single-engine aircraft by **partially closing** the throttle. By partially closing the throttle during the climb out, and briefing the student to treat this as a total power failure, the student has the opportunity to carry out the correct action of closing the throttle.

It cannot be stressed enough that you must keep in mind the objective and the safety of the aircraft while providing the student with the opportunity to practice **command decision-making**. Once the aircraft nose has been lowered, a decision made as to the landing site, and an attempt made to position for a landing, the objective has been achieved, and the instruction to "go-around" should be given. Only after these basic actions have become automatic, and where height and time permits, should any attempt to complete checks be encouraged.

ENGINE FAILURE AFTER TAKE OFF

OBJECTIVE:

To adopt the recommended procedure in the event of engine failure at low level.

CONSIDERATIONS:

Probable causes

- Fuel contamination (something in fuel)
- Fuel starvation (fuel not feeding)
 - engine driven fuel pump failure
- Fuel exhaustion (no fuel on board)
- Carb. ice
- Carb. air filter blockage
- Mechanical failure

Aborted T/O (during T/O roll)

Check for normal readings early in take-off
Abort if engine runs rough or if instructed by ATC

EFATO **Low airspeed - high nose attitude - low altitude - little time!**
Landing Site Selection

Choose anything in the windscreen

Within easy reach - into wind - avoid major obstacles **Keep cabin intact**
Do not attempt to turn back to the runway (the impossible turn)

Before Take-Off Safety Brief

Engine failure during the take-off: Close throttle, keep straight and use brakes as required

Engine failure after take-off: - Assess wind

(situational awareness) - Visualise possible landing sites into wind
- Modify plan based on local knowledge

AIRCRAFT MANAGEMENT:

Fuel system - systems knowledge

Loose articles - pre-flight check

EFATO simulation commences

- "simulating" & partial power

Touch checks in **red**

- **simulation ends with "go-around"**

Smooth, positive throttle use

NO SOLO PRACTICE

Instructor advises ATC/traffic

AIR EXERCISE:

1. Takeoff Safety Brief

2. Aborted Takeoff

- Close throttle, keep straight
- Brakes as required
- Advise ATC
- If over run likely - **F M I**
- Keep cabin intact

3. EFATO

Initial actions **AVIATE** - lower nose and close throttle

NAVIGATE

- Follow takeoff safety brief
- Choose landing site (ahead)
- Within easy reach
- Avoid MAJOR obstacles
- Keep the cabin intact
- Use flap as required

IF TIME PERMITS

Trouble Checks (red = touch check)

- Adopt best glide - carb. heat hot
- Fuel pump on, **change tanks**, primer locked
- Mixture rich
- Ignition on **both**
- Check for power

Shutdown Checks

- F** Fuel selector off
- M** Mixture idle cut off
- I** Ignition off

Mayday call **Transponder 7700** **Master OFF** (flap)

Flapless Circuit

This briefing primarily deals with the differences between a normal approach and the flapless approach. Therefore, although there are **some** circuit considerations, you may prefer to use the more descriptive title of Flapless Approach or Landings.

Circuit Considerations

This briefing and exercise is normally practised before first solo (refer CFI) to prepare the student against the unlikely event of flap failure during early solo circuit consolidation. Therefore, it must be assumed that flap failure will not have been detected before starting the base turn, where flap is first selected.

What should the student do? Continue with the approach, switching from an approach with flap to flapless, or go-around, re-circuit and prepare for the approach downwind? Clearly, if there are no other factors to be considered such as fuel or weather, the go-around is the better option.

Now the briefing can continue on the assumption that the flap are known to be unserviceable, and emphasis is placed on preparation for the flapless approach and landing.

Introduction

The flap on this aircraft are operated by _____ (mechanical/electrical/pneumatic) means. Although the possibility of failure is rare, we need to know how the aircraft flap system works and what can be done, not only to deal with any problems arising from its operation, but also how to prevent them occurring.

In addition, the pilot-in-command may elect to make a flapless approach, for example, at international aerodromes or where strong crosswinds exist. In all cases where a systems failure or unexpected deviation in procedures occurs –

AVIATE – NAVIGATE – COMMUNICATE

It is probable that a flap failure will not be detected until flap is selected, usually in the base turn. This is no place to deal with a systems failure, so a go-around is carried out. The climb to circuit altitude uses the full length of the climb-out leg, giving a long downwind leg to consider options and prepare for the flapless approach. Therefore, this exercise starts from the downwind leg with the knowledge that the flap will not extend.

Objective

To approach and land without the use of flap.

Principles of Flight and Considerations

The most probable causes of flap failure are mechanical linkage failure (manual or electric flap), electric flap motor failure, or electrical current failure.

The risk of these failures is minimised through the pre-flight inspection, aircraft systems knowledge and in-flight SADIE checks (A = Amps or Alternator).

Another possible cause, that should never occur, is flap overspeed. If the flap are extended or left extended at speeds in excess of the manufacturer's recommendation the flap or linkages may buckle and jam. If this occurs, flap retraction may not be possible, with a consequent degradation in flight performance. Worse than this, is the possibility that the flap will retract unevenly, causing uncontrollable roll. A third possibility is that loads on the electric flap motor will cause it to burn out with the consequent risk of fire.

This malfunction is simply avoided by never exceeding the V_{FE} (Velocity for flap extension - white arc) with flap extended.

Once the aircraft is established in level flight at a safe altitude, the possible causes of the systems failure can be considered.

The simplicity of the manual flap extension system requires minimal systems knowledge. Electrically operated flap require more systems knowledge and provide the student with the opportunity to practice problem-solving.

Regardless of the flap type, it is recommended that this briefing discuss the aircraft electrical system, depending on its complexity, under Aircraft Management. You may prefer to discuss the aircraft electrical system as a separate pre-flight briefing during circuit training, and this is not discouraged (refer CFI).

If electrically operated flap fail, check the master switch is ON, the flap circuit breaker set or reset, and the alternator or generator output and battery state tested (if applicable). In addition, a visual check of flap position is made to ensure that it's not just the flap position indicator that has failed. The visual check can also look for any asymmetric condition.

Flaps increase lift and drag, and the benefits of these have been seen in the normal landing. The considerations of approaching and landing without flap are discussed next.

With flap up the stalling speed is greater than with flap extended. To retain the same margin of airspeed over the stall speed, the approach and threshold speeds are increased, by about the difference in the aircraft stall speed clean and the stall speed with full flap. Commonly, for light aircraft about 5 kts, but for the B737, for example, 55 kts.

This increase in threshold speed will result in a longer landing distance, and therefore the suitability of the runway should be considered. Neither the group rating system nor the P-Charts allow for a flapless landing.

Without the increased drag provided by flap, the power setting required to control the descent will be lower, the descent angle will be shallower, and forward visibility will be poorer.

Aircraft Management

The aircraft flap and electrical systems are described, with emphasis on their inter-relationships, through schematics, actual components, models and handouts (refer aircraft Flight Manual).

As a result of the decreased drag, only small power changes will be required to alter the rate of descent.

Human Factors

The effects (ADVISE mnemonic) of **V**ision, **D**isorientation, **I**nformation processing and **S**tress are the prime considerations in this briefing.

Situational awareness is improved through systems knowledge and routine systems checks (SADIE).

Information processing and decision-making are improved through the use of systems checklists and prioritising.

Immediate stress is reduced through knowledge, practice and prioritising (**aviate – navigate – communicate**).

Air Exercise

A flap failure will be simulated at the base turn or when flap is first selected, and a go-around carried out.

Downwind

The systems checks are carried out (if applicable) as well as the normal radio call and downwind pre-landing checks.

The suitability of the runway in use is considered and a decision made on the appropriate threshold speed to be used.

If the runway in use is not suitable and a diversion to another aerodrome is preferred, practice in this procedure should be given before first solo (refer CFI).

Downwind spacing is assessed, and an appropriate power setting at the base turn point is selected. Because of the decreased drag without flap and the desirability of a powered approach, it is common practice to extend the downwind leg and set the same power setting as a normal circuit, so that some power will have to be used throughout the approach.

An alternative method to stretching the circuit out is to extend downwind only slightly and use a much lower power setting initially. As the aircraft sinks onto the correct glide slope or approach path, power is slowly increased until the desired rate of descent is achieved. The aim point should not move up or down but remain steady in the windscreen.

Base

The base turn is normal except for the lower power and higher nose attitude selected – trim. Because of the aircraft higher inertia, the turn onto final will need to be anticipated earlier.

The Approach

Is flown as normal with the attitude selected to maintain the higher approach or threshold speed and trimmed. Only small adjustments in power should be required to control the rate of descent.

The noticeable differences in this approach are the higher nose attitude required to maintain the desired airspeed and the effect of power changes on the rate of descent. As always, if attitude or power are altered, some adjustment to the other component will be required to maintain the desired performance.

Attitude + Power = Performance

Because the aircraft is already in a higher nose attitude than normal with a lower rate of descent than normal, the round-out is less pronounced and only a slight hold-off is used. The aircraft is then allowed to sink in a slightly nose-high attitude to prevent the nosewheel taking the landing loads. The nosewheel is then lowered and brakes applied as required, aft elevator being used to keep the weight off the nosewheel.

A common student error is to attempt to hold-off and land in a very high nose attitude, which results in considerable float, increasing the landing distance and the possibility of a tail strike.

As with all powered approaches, it is desirable to touch down just inside the threshold. If a prolonged float is permitted to develop, a go-around may be appropriate.

Airborne Sequence

After the simulation of flap failure, and the repositioning of the aircraft downwind by the student, the airborne sequence is standard.

As the student is familiar with holding off for the normal landing, resisting this action and allowing the aircraft to sink onto the runway may take some practice.

If the student allows the aircraft to float, even though you will want to see the student make their own decision, it may be necessary to remind the student to go-around.

Regardless of whether the decision to go-around is initiated by the student or not, this facet should be debriefed in accordance with ADM principles¹⁴².

¹⁴² refer Simuflight, 1996

FLAPLESS CIRCUIT

OBJECTIVE:

To approach and land without the use of flap.

CONSIDERATIONS:

Probable causes

- Manual (PA 38) - mechanical linkage
- Electric (C-152) - servo linkage
 - flap motor failure
 - master off
 - circuit breaker
 - alternator failure - flat battery?
- Flap over-speed
 - Visual check flap selector - flap position
 - Asymmetric?

Avoided by

- Pre-flight inspection
- actuating rods, hinges

SADIE

Never exceed Vfe

Effects of not using flap on approach and landing

- **Vs** ↑ : approach & landing speeds higher (B737 +55 kts)
- longer ground roll - consider runway length (divert?)
- less drag : requires lower power setting
- shallower descent
- reduced visibility

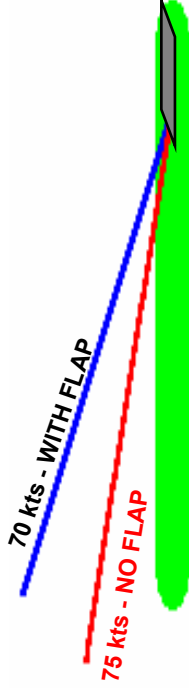

AIR EXERCISE:

- 1. Simulated flap failure at base turn - go-around**
- 2. Downwind** - systems check
 - nominate approach/threshold speed
 - consider runway length (divert)
 - normal radio call, landing checks and assess spacing
 - approaching 45 deg extend downwind slightly
 - ↓ power as required (less than normal circuit)
 - turn onto base, at ___ kts - select attitude & trim
- 3. Base**
 - maintain ___ kts - trim
 - anticipate centre-line
 - lookout
 - descending turn onto finals
- 4. Finals** **Attitude + Power = Performance**
 ___ kts ROD Approach Path
- 5. Landing**
 - anticipate less round out
 - fly on in slightly nose-high attitude (nosewheel)
 - lower nosewheel
 - brakes as required (keep weight off nosewheel)

AIRCRAFT MANAGEMENT:

Systems Knowledge

- Flap
- Electrical

Drag

- Small power changes
- Reduced visibility

HUMAN FACTORS:

Situational Awareness

- Systems knowledge

SADIE

Information Processing

- Checklists
 - Priorities (go-around - plan)
 - Visual landing cues changed
- Stress** - Regular practice

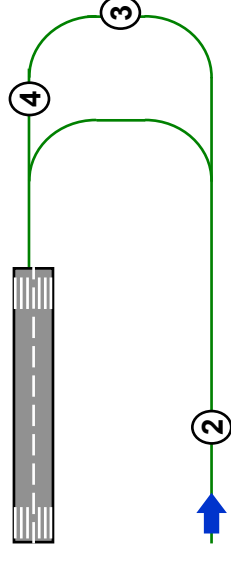

Crosswind Circuit

This briefing primarily deals with the differences between a normal circuit, where the wind is straight down the runway in use, and a circuit where the wind is at an angle to the runway in use.

Since taxiing in any wind will invariably result in some crosswind being experienced, the correct positioning of the aircraft controls during taxiing are revised in this briefing.

Introduction

During taxiing and throughout the takeoff and landing, when the wind is at an angle to the runway, the aircraft will have a tendency to ***weathercock*** or swing nose into wind.

When climbing out or approaching to land, with the wind at an angle to the runway, an allowance for drift will need to be made so that the aircraft tracks straight over the ground along the extended centre-line.

The student should already be familiar with compensating for drift on the crosswind and base legs of the circuit. But the aircraft cannot land without being aligned with the runway without the risk of damage to the undercarriage or the aircraft running off the runway.

Objectives

1. To correctly position the aircraft controls while taxiing.
2. To compensate for drift throughout the circuit.
3. To takeoff and land in crosswind conditions.

Considerations

Revise the correct positioning of aircraft controls during taxiing (refer aircraft Flight Manual) – OHP recommended.

Maximum Demonstrated Crosswind

The maximum demonstrated crosswind component (in knots) in the Flight Manual, is the figure at which factory testing has shown that directional control can still be maintained. It is affected by the size of the rudder, its distance from the C of G, and the availability of asymmetric braking. It is not a legal limitation but a guide to what limit should be applied to crosswind landings. It is modified by several factors, for example, technique, individual currency and competency. The maximum demonstrated crosswind component for this aircraft should be stated, as well as any club or organisation limit.

Calculation of Crosswind Component

The various methods of calculating the crosswind component are described.

To calculate the crosswind component the pilot must first know or estimate the wind velocity (W/V) – speed and direction.

This information may be provided by Meteorological Aerodrome Reports (METAR), Terminal Aerodrome Forecasts (TAF), the Automatic Terminal Information Service (ATIS), the ATC control tower, or windsocks.

METAR and TAF winds are given in degrees true and must first be converted to magnetic in order to calculate the angular difference between runway heading (magnetic) and wind direction.

In some instances the crosswind component may be stated - requiring no further calculations.

Once the angular difference between wind direction and the runway heading is known, the various methods of calculating the crosswind component can be discussed.

Vector Diagram

The vector method requires pencil, paper, protractor and ruler. As an example, assume a W/V of 240 degrees magnetic at 20 kts and a runway heading of 210 degrees (21). Calculate the angular difference between the runway and the wind direction; this is the wind angle, in this case plus 30 degrees. Draw a vertical line to represent the runway. From near the bottom of this line, draw a line at the wind angle from the vertical, 20 units (wind speed) long. Break this vector down into its vertical and horizontal components and measure these to give headwind (18 kts) and crosswind (10 kts).

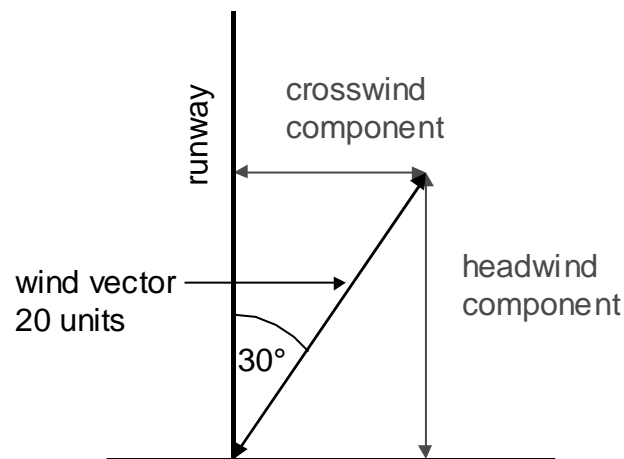

Aircraft Flight Manual

Commonly, a vector diagram is supplied in the aircraft Flight Manual in graph form and is a more practical method of calculating X/W.

It's a good idea to include a photocopy of this graph in the handout to this lesson and to have an enlarged plasticised version for reference during the briefing.

Navigation Computer

Although the presentation is a little different, the same calculation can be made using the navigation computer.

ATIS or ATC

Although ATIS and ATC give the wind direction in magnetic they do not always give the X/W component. Therefore, a mental calculation may be required (see Formula below).

Windssocks

Most aviation windssocks are 25kt windssocks. This means that when the wind strength is 25 kts the windssock stands straight out. The angular difference between runway and wind direction is estimated visually and may require a mental calculation to derive the X/W component (see Formula below).

Formula

For the mathematically minded only! The X/W component is equal to the speed (V) of the wind multiplied by the sine of the angular difference ($X/W_c = V \times \text{Sine}\theta$). Therefore, in the example given above (Rwy 21 - W/V 240/20) the angular difference is 30 degrees, and the sine of 30 degrees is 0.5. This means that half the wind strength is X/W ($20 \times 0.5 = 10$).

This method requires a calculator or memorisation of the various sines of angles between 0 and 90 degrees. It may be more practical to memorise the sine of only two angles, 30 degrees = 0.5 wind strength and 50 degrees = 0.75, 3/4 or 75% wind strength. At angles greater or less than this the X/W component can be estimated as plus or minus (refer CFI).

Tower

Where ATC is provided on the aerodrome the simplest method of determining the crosswind component is to request it from the tower.

Aircraft Management

The aircraft can land in crosswinds of greater than the demonstrated crosswind component provided the correct technique is used.

The ability to maintain directional control about the normal axis is the limiting factor for crosswind landings. Although it may be easy enough to keep the aircraft aligned with the runway during the round-out and landing, as the airspeed decreases, rudder effectiveness will reduce and it may be difficult to prevent weathercocking. Therefore, as the crosswind component increases, the amount of flap used for the landing is normally reduced. This reduces the surface area on which the crosswind can act after landing and therefore improves directional control.

Although the landing distance may be adequate when calculated using the group rating system or P- charts, any landing with reduced flap will increase the landing roll. In addition, if the crosswind is not steady an increase in approach speed may be required to compensate for windshear and gusts.

Therefore, the pilot-in-command must consider the runway's overall suitability in relation to X/W component, approach/threshold speed and available length.

Although the approach speed is increased for a flapless approach, because of the small range of stall speeds (with and without flap), it is common practice in most light training aircraft to maintain the normal circuit approach speed at intermediate flap settings (refer CFI).

Where this exercise is simulated using a non-active runway, aircraft taking off and landing into wind have right of way.

When taxiing in strong winds it is advisable to request wingtip assistance.

Human Factors

The effects (ADVISE mnemonic) of **D**isorientation and **S**tress are the prime considerations in this briefing.

Situational awareness is emphasised in the calculation of the crosswind component, gustiness, aircraft limitations and aircraft configuration.

Stress is reduced through exposure and knowledge of personnel limits and good decision-making.

In accordance with ADM principles, the student should be asked on subsequent flights to assess other runways for landing suitability.

Air Exercise

On lining up, the high reference point used to keep straight during the climb will need to be selected to prevent drift and provide a straight track over the ground along the extended centre-line. The ailerons are fully deflected into wind and the elevator maintained neutral or very slightly down.

During the takeoff roll the amount of aileron is reduced as the increasing speed makes the ailerons more effective and **some** weight retained on the nosewheel to improve directional control.

At a safe flying speed the aircraft is rotated with ailerons neutral. The aim is to prevent the aircraft from skidding sideways across the runway by lifting off cleanly. In addition, the higher rotate speed will allow the aircraft to accelerate quickly to the nominated climb speed. Soon after lift off a **gentle** balanced turn is made into wind using the nominated high reference point as a guide in offsetting the drift.

During the climb out, ensure the wings are level and the aircraft in balance. Check for straight tracking and adjust the reference point as necessary to maintain runway centre-line.

On the crosswind leg, an allowance for drift is made in the normal way but a component of head or tail wind may become apparent in the distance travelled over the ground to reach circuit altitude.

The turn onto downwind should be made at the same distance out as a normal circuit. However, a strong crosswind toward the runway will decrease the time spent on the base leg and therefore, a wider downwind leg may be advisable. In addition, the effects of head or tail wind on the crosswind leg may require less or more anticipation of when to start the turn onto downwind. A suitable reference point, so as to track parallel to the runway, is chosen. The considerations of the approach are assessed and a decision made on runway suitability, approach/threshold speed and maximum flap setting to be used. The correctness of the downwind spacing is assessed and the reference point altered to maintain a parallel track if necessary.

The turn onto base is normal and continued onto a suitable reference point with an allowance for drift.

Once established on base additional flap, up to the maximum to be used for the landing, is normally extended.

The head or tailwind component experienced on base will affect the turn onto final and must be anticipated. The turn is continued onto a suitable reference point into wind that allows for drift, and tracks the aircraft straight along the extended centre line; this is called **crabbing**.

Throughout the descent the aiming point is monitored in the normal way and the power adjusted as required to maintain a steady rate of descent to touch down – power controls the rate of descent¹⁴³.

There are two methods of carrying out the landing, the **kick straight** method and the **wing down** method.

The Kick-Straight Method

The advantage of this method is that the aircraft is flown in balance throughout the approach, round-out and hold-off.

¹⁴³ Campbell, 1994, p.13-19

Throughout these phases the aircraft is crabbed into wind and just before touch down, brisk or positive rudder is used to yaw the aircraft nose into line with the runway using into-wind aileron as required to keep the wings level.

Although this method sounds simple at first, it takes considerable skill in timing the application of rudder. Too early, and the aircraft will drift downwind, touching down with sideways loads, perhaps off the runway. Too late, and the aircraft will touch down at an angle to the runway, applying large sideways loads and the aircraft may rapidly depart the runway.

The Wing-Down Method

The advantage of this method is its ease of execution.

On short final the aircraft nose is aligned with the runway by applying a squeeze of rudder and sufficient aileron applied, into wind, to prevent drift. This results in the aircraft **sideslipping** into wind at a rate that negates the drift.

The round-out and hold-off are flown in this wing down attitude and the landing made on the windward wheel first.

Although this method sounds more difficult, it is actually easier to execute and requires less judgement.

Many modern light aircraft have a restriction on sideslipping, especially with flap extended, and therefore the recommended procedure is a combination of these two methods.

Throughout the approach, the aircraft is crabbed into wind, in balanced flight, preventing drift.

During the round-out, the wing down method is applied. The aircraft nose is aligned with the runway through smooth rudder application and sufficient aileron into wind used to prevent drifting off the centre-line.

This should not require full or even large control deflections. If large amounts of aileron are required to maintain the centre-line, then it is unlikely that rudder effectiveness will be sufficient to keep straight throughout the landing roll. In this situation a go-around should be carried out and the runway's suitability reconsidered.

The landing is made on the windward wheel, which will create a couple that lowers the other main wheel. The rudder is centralised and the nosewheel lowered rather than held off and **some** weight maintained on the nosewheel for directional control. At the same time, aileron into wind is increased as the speed reduces.

Throughout the landing a small amount of power (1200 rpm) **may** be used to improve control and the throttle closed after touch down.

Keep straight on the runway centre-line by reference to a point at the far end of the runway and apply differential brakes **as required**.

No more than neutral elevator should be used to put some weight on the nosewheel so as to avoid *wheel barrowing*.

Airborne Sequence

The airborne sequence is standard with a demonstration, follow through, talk through and student practice.

Where practical, the student should be gradually introduced to crosswinds of increasing intensity, commensurate with skill.

CROSSWIND CIRCUIT

OBJECTIVES:

1. To correctly position the aircraft controls during taxiing.
2. To compensate for drift throughout the circuit.
3. To take-off and land in crosswind conditions.

CONSIDERATIONS:

Control positioning while taxiing (refer A/C Flight Manual) - OHP recommended.

Maximum Demonstrated X-Wind Component - as per Flight Manual

Methods for Calculation of X-Wind Component (runway & W/V known)

- 1) Vector Diagram
- 2) Flight Manual Graph
- 3) Navigation Computer
- 4) ATIS - ATC
- 5) Windsock
- 6) Formula $XWc = V \times \sin \theta$
- 7) Tower

Wind 240/20

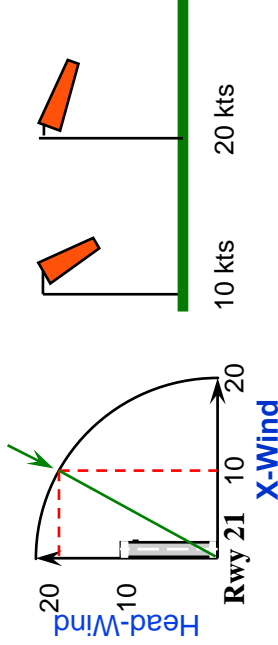

θ	10	20	30	40	50	60	70	80	90
Sin	.20	.35	.50	.65	.75	.85	.95	.99	1.0

AIRCRAFT MANAGEMENT:

Rudder effectiveness

'Weathercocking' - flap

Runway - suitability

Wing-tip assistance

HUMAN FACTORS:

Situational Awareness

Wind - X/W calculation

- Characteristics (gusts etc)

- Circuit Adjustments

- A/C Configuration

Stress - Personal Limits, in doubt Go-around

- Currency

Decision Making

AIR EXERCISE:

Line up

- Select a suitable high reference point
- Hold elevator neutral or **slightly** forward
- Ailerons into wind

Take Off

- Reduce aileron deflection as A/S increases
- Maintain **some** weight on nosewheel
- At ___ kts positive rotation
- Gentle turn into wind (Ref. Pt.)

Climb out

- Crab into wind
- Wings level
- In balance
- Check track made good

Circuit Base

- Drift correction
- Anticipate turn onto final

Approach

- Crab into wind
- Use a reduced flap setting

Landing

- During the round out**
- Straighten up with rudder (squeeze)
- Aileron into wind to prevent drift (wing down)
- Windward wheel will touch down first
- Increase aileron into wind as speed decreases
- Lower nose wheel (elevator neutral - wheelbarrowing)
- Maintain directional control (A/C wants to weathercock into wind)

Crab approach on final

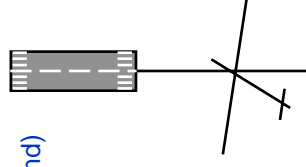

The Standard Overhead Join

The standard overhead join procedure is the **standard** method for joining the traffic circuit at an aerodrome.

It is used when the pilot-in-command needs to find out the runway in use, familiarise themselves with the aerodrome traffic and conditions, or when it is required by ATC.

Introduction

Rule 91.223 *Operating on and in the vicinity of an aerodrome* requires the pilot to “... observe other aerodrome traffic for the purpose of avoiding collision, and, unless otherwise authorised or instructed by ATC, conform with or avoid the aerodrome traffic circuit formed by other aircraft.” The standard overhead join procedure is a recommended means of complying with this rule.

This lesson looks at how to join the aerodrome traffic circuit at an uncontrolled aerodrome. There will be no ATC instructions, and there may be no ATIS to forewarn the student of runway in use and wind conditions.

There are several reasons why the runway in use may not be known. The most common is joining at an uncontrolled aerodrome. If the aerodrome is listed in the VFG, circuit direction will be shown on the aerodrome chart. This information and an estimate of the surface wind can provide a cue to the circuit direction.

If the runway in use is known, the pilot may elect to carry out the standard procedure when they are unfamiliar with the aerodrome layout and any other traffic.

The term **overhead** is used because we fly over the aerodrome at a safe altitude above the circuit to look down and determine which runway is in use, or most suitable, and to sight any traffic.

For this exercise we will simulate no knowledge of the active runway or traffic in the area.

Objective

To join an uncontrolled circuit in accordance with the standard overhead join procedure.

Considerations

The standard overhead join procedure is carried out to determine which runway is in use and to check for traffic. It enables the pilot-in-command to observe other aerodrome traffic in order to avoid collision and to either conform with or avoid the traffic already in the circuit.

The information available from the aerodrome chart that is pertinent to the standard overhead join procedure is discussed. This includes aerodrome elevation, runways available and their suitability, circuit directions, the location of windsocks and how to hold the chart to aid orientation. Where the aerodrome is unfamiliar to the student, a study of the aerodrome chart should be carried out before flight.

Discuss the need to terminate the flight plan with ATC after landing at uncontrolled aerodromes.

Aircraft Management

Before entering the circuit, the aircraft speed will need to be reduced to below 120 kts, as circuit speeds are normally restricted to this. Landing light should be on.

The aircraft communication system should be described if it has not been discussed before this point.

Preparing the aircraft for arrival is an aircraft management consideration and involves the use of the VFG, Visual Terminal Chart (VTC) and joining checklists.

The pertinent right-of-way rules are revised and the requirement to make turns in the circuit direction emphasised.

Human Factors

The effects (ADVISE mnemonic) of **D**isorientation, **V**ision, **I**nformation processing and **S**tress are the prime considerations in this briefing.

The need to maintain situational awareness to avoid disorientation is discussed, especially in relation to the orientation of the landing chart and any visible indications of the general wind direction.

The limitations of vision are revised in relation to cabin obstructions and scan rate.

Information processing limitations and their effects on attention and perception are discussed¹⁴⁴.

Stress is reduced through aircraft systems knowledge, compliance with a rule-based procedure, and practice.

Air Exercise

When joining at an unattended aerodrome, which includes controlled aerodromes when ATC is off watch, a radio call addressed to the circuit traffic is made between 5 and 10 nautical miles from the aerodrome, stating aircraft position and intentions. The standard overhead join procedure is carried out in three main phases.

Approach

Approach the aerodrome to cross overhead at not less than 1500 ft above aerodrome level (refer landing chart) **unless** otherwise stated on the landing chart; for example, at Palmerston North 1500 ft amsl is used because of airspace.

Overhead does not mean directly over the centre of the aerodrome, as this would make it very difficult to see any of the aerodrome features or traffic. The aircraft should be positioned so that the aerodrome is close by, on the port side of the aircraft, so that the student (not you) can look down and across the whole aerodrome, observing traffic, windsocks and ground signals or markings.

Not less than 1500 ft above aerodrome level means round up; for example, if aerodrome elevation is 150 ft, rejoin altitude would be 1650 or 1700 ft not 1600. Generally we do not join at levels higher than 1500 ft agl because, assuming there is no overlying airspace restriction, it becomes harder to distinguish the windsocks with increasing altitude and more altitude will have to be lost on the descent. In addition, if all aircraft rejoin at the same altitude it should be easier to see each other.

The reason for rounding up is to maintain a 500-ft buffer over aircraft in the circuit, who may have rounded up the circuit altitude.

¹⁴⁴ refer O'Hare & Roscoe, 1992

Determine Runway in Use

Determine the runway in use by reference to the windsocks, or other traffic already established in the circuit. All subsequent turns are made in the circuit direction.

If the runway in use **cannot** be determined quickly turn to the left and orbit overhead. If it is determined that a righthand circuit is in use, make all further turns to the right.

Aircraft already in the circuit have right of way. This means that if aircraft in the circuit are using a runway considered unsuitable for your operation, the responsibility of avoiding conflict is on the joining aircraft, even if the runway in use is out of wind.

Once the runway in use has been established and the circuit direction is confirmed (refer VFG), a turn is made in the circuit direction (left or right as applicable) to position the aircraft on the non-traffic side of the aerodrome. As aerodromes are potentially areas of high traffic density, use no more than a medium bank angle.

Regardless of which way the aircraft is turning, the turn is continued until the centre-line of the runway in use is crossed, and the aircraft enters the non-traffic side.

Avoid giving too much attention to ground features during these phases, maintaining a lookout for other aircraft is more important. Be aware that NORDO aircraft, which may be carrying out this procedure, will not be heard and must be seen.

Descend to Circuit Height

Before descending, both the traffic side and non-traffic side must be identified to avoid descending onto aircraft in the circuit. There is no time constraint, other than fuel, in establishing the non-traffic side. One method of identifying the traffic side is to have the student imagine they are lined up on the chosen runway ready for takeoff. If they were to takeoff which way would they turn at 500 ft – this establishes the traffic side.

Descend to circuit altitude when established on the non-traffic side. Due to the potentially high traffic density around an aerodrome, a low rate of descent is preferred. Common practice is to use a cruise or powered descent.

The aircraft must cross onto the traffic side of the active runway **only when at circuit altitude**. They must also track over the upwind threshold. Crossing the upwind threshold provides the longest possible downwind leg, while at the same time still providing maximum vertical separation from high-performance aircraft taking off.

On this crosswind leg, correct for drift, in order to track at right angles to the runway. A good lookout will need to be maintained for aircraft flying on the downwind leg. **Do not** turn in front of any such aircraft; always position behind.

As the downwind leg will be shorter than normal, the pre-landing checks are completed during the descent on the non-traffic side or on the crosswind leg (refer CFI).

The downwind radio call is made as soon as the aircraft is established on the downwind leg, and the circuit is completed in the normal manner.

Airborne Sequence

Vacating the circuit is demonstrated or patterned.

The exercise begins at between 10 and 5 miles from the aerodrome, normally over a local feature or VFR reporting point.

The standard overhead join procedure is then carried out. Commonly, only a talk-through and student practice is required. The decision to demonstrate or follow through depends on your assessment of student ability.

From the downwind leg, an approach and landing or go-around can be carried out before vacating the circuit for student practice. Since the objective of this exercise, however, was to join or rejoin the circuit, the landing portion can be skipped and the circuit may be vacated from the downwind leg.

THE STANDARD OVERHEAD JOIN

OBJECTIVE:

To join an uncontrolled circuit in accordance with the standard overhead join procedure.

CONSIDERATIONS:

- Reasons for a standard circuit rejoin**
 - Unattended aerodrome
 - To check aerodrome layout, circuit in use and other traffic
- Flight guide** (Aerodrome chart)
 - Elevation
 - Runways available - length
 - Circuit directions
 - Windsock positions
 - Magnetic North

Terminate flight plan after landing at unattended aerodrome with ATC.

AIRCRAFT MANAGEMENT:

120 Kts. Maximum circuit speed

Landing light on

Plan Ahead - rejoin checks
- pre-landing checks

All turns in circuit direction

Aircraft in circuit have right of way

HUMAN FACTORS:

Situational Awareness - chart, W/V

Vision - **Lookout** & Listen-out

Info Process - attention, perception

Stress - systems knowledge
- rule based procedure
- regular practice

AIR EXERCISE:

- Radio call** - between 10 & 5 nm
- Approach** - (A/C's lefthand side) at not less than **1500' AAL**
- Determine runway in use** - all subsequent turns made in that direction

Note: Example diagram is for a left hand circuit

If runway in use cannot be determined, orbit overhead in a left hand turn until it can be.

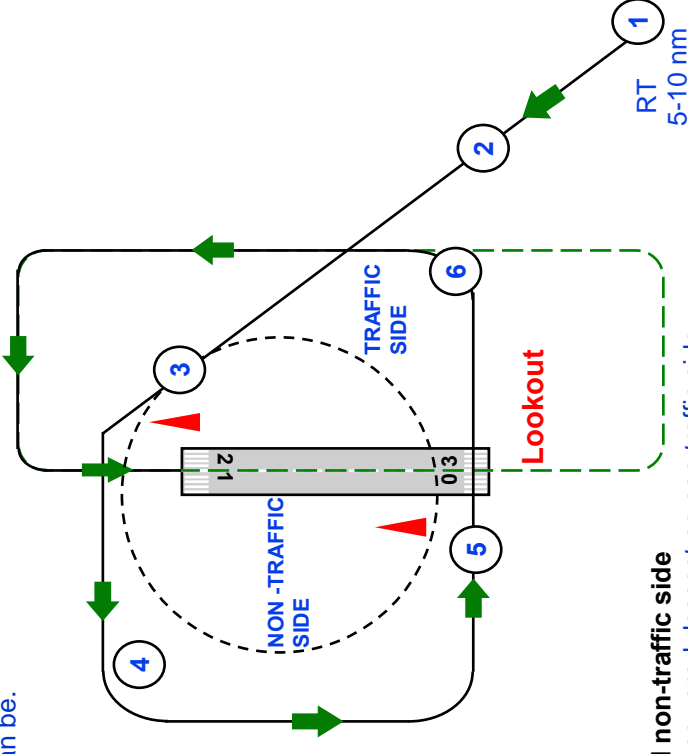

- Descend non-traffic side**
Commence powered descent on non-traffic side
- Cross upwind threshold at circuit height LOOKOUT!**
 - Drift & traffic separation
 - Pre-landing (downwind) checks
- Downwind call** - Complete normal circuit

Vacating and Joining the Circuit

This lesson primarily deals with vacating controlled and uncontrolled aerodromes and joining the circuit at a controlled aerodrome.

Introduction

This lesson discusses the various procedures available for leaving and joining an aerodrome traffic circuit when the active runway is known.

Objective

To vacate and join the circuit at either a controlled or uncontrolled aerodrome in accordance with the various applicable procedures.

Considerations

Uncontrolled Aerodromes

Vacating the uncontrolled aerodrome is discussed first as, with a clearance, any of these methods are also available at controlled aerodromes.

Leaving the circuit at an uncontrolled aerodrome is usually done from one of the circuit legs, for example, crosswind, downwind, or climbing to overhead; turns are always in the circuit direction. Alternatively, the uncontrolled circuit may be vacated by climbing straight ahead on the runway heading to 1500 ft above aerodrome level.

Although it is legal to join an uncontrolled aerodrome by joining at circuit altitude on virtually any of the aerodrome traffic circuit legs, it is not necessarily good aviation practice. The only method recommended here for joining the circuit at an uncontrolled aerodrome is the standard overhead circuit join procedure (refer CFI).

Controlled Aerodromes

When vacating a controlled aerodrome, all of the above options are available. In addition, a clearance to turn in the opposite direction to the published circuit may be given by ATC, or may be requested by the pilot. If a non-standard clearance is required, maintain situational awareness, and request it **before** takeoff.

When joining at a controlled aerodrome, the pilot-in-command always has the option of requesting a standard overhead join. This is desirable when the pilot is unfamiliar with the aerodrome layout, the active runway, or the position of the various circuit legs. Also, ATC has the option of instructing the pilot to carry out a standard overhead join.

In each of these cases, the pilot knows the runway in use and, since the ATC clearance for joining will specify the circuit direction, the aircraft is positioned over the aerodrome with knowledge of the circuit direction in use. This is the only difference between the standard overhead circuit join procedure and joining overhead at a controlled aerodrome. If the circuit in use is lefthand then the pilot keeps the aerodrome on the left; if the circuit is righthand then the pilot keeps the aerodrome on the right. Overhead, all turns are made in the circuit direction, and the descent is carried out on the non-traffic side as normal.

The other method of joining at a controlled aerodrome circuit is to be cleared by ATC to join on the downwind, base, or final approach legs. Such a clearance may be for an

aerodrome traffic circuit opposite to the published circuit for that runway; for example, “join right base” for a runway with a lefthand circuit.

It is good aviation practice to establish the aircraft on an **extension** of the circuit leg to be joined, well before reaching the circuit area.

Where ATC is in attendance but ATIS is not available, common practice is to request joining instructions. ATC will inform the pilot of the conditions and clear the pilot to join the circuit in the most appropriate way.

When ATIS information has been received before reaching the reporting point for circuit joining, the pilot should state or request from ATC the preferred method of joining.

A clearance to join downwind, base, or final does not absolve the pilot from giving way to other aircraft already established in the circuit.

Aircraft Management

Before joining the circuit, the airspeed should be reduced to below 120 kts and landing lights turned on.

If a downwind leg will not be flown, the aircraft is prepared for landing before circuit entry by using joining and pre-landing checks.

Human Factors

The effects (ADVISE mnemonic) of **V**ision, **I**nformation processing and **S**tress are the prime considerations in this briefing.

The limitations of vision are revised in relation to closure rates and objects that do not produce relative movement.

Information processing limitations and the use of mental models to retain situational awareness are discussed, thereby helping the student to draw a mental picture of the position of reported traffic.

Stress is reduced through compliance with a rule-based procedure and through practice.

Air Exercise

The air exercise describes vacating the circuit in a manner appropriate to your aerodrome. As the recommended procedure for joining an uncontrolled aerodrome traffic circuit is the same as the standard overhead join procedure, only joining at a controlled aerodrome need be discussed here.

The appropriate radio calls and checklists are discussed in relation to the shortened circuit.

Airborne Sequence

This exercise need not **necessarily** be flown as an individual exercise but may be combined with any training area exercise (refer CFI).

VACATING & JOINING THE CIRCUIT

OBJECTIVE:

To vacate and join the circuit at either an uncontrolled or controlled aerodrome in accordance with the various applicable procedures.

CONSIDERATIONS:

Uncontrolled aerodromes

Vacating the circuit

- From any of the circuit legs or overhead
- Or maintain runway heading to 1500' AGL

Joining the circuit

- Preferred method is via the Standard Overhead Join
- Can join from any leg

Controlled aerodromes

Vacating the circuit

- Can be done from any leg
- Always need ATC approval

Joining the circuit

- Can request overhead rejoin
- Join on downwind, base or final in accordance with ATC clearance

AIRCRAFT MANAGEMENT:

Below 120 Kts prior to joining

Plan Ahead

- re-join checks
- pre-landing checks

Aircraft in circuit have R.O.W

HUMAN FACTORS:

Vision

- Blind spots
- Closure rates

Info Processing

- Mental models

Situational awareness

Stress

- Rule based procedure
- Regular practice

AIR EXERCISE:

1) Vacating uncontrolled aerodrome

(Left Traffic Circuit)

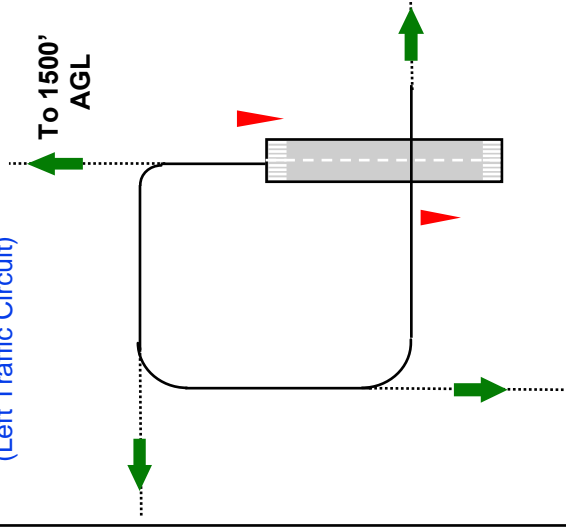

2) Vacating controlled aerodrome

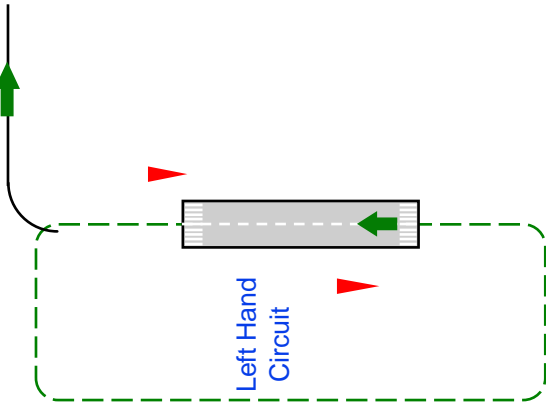

3) Joining at a controlled aerodrome

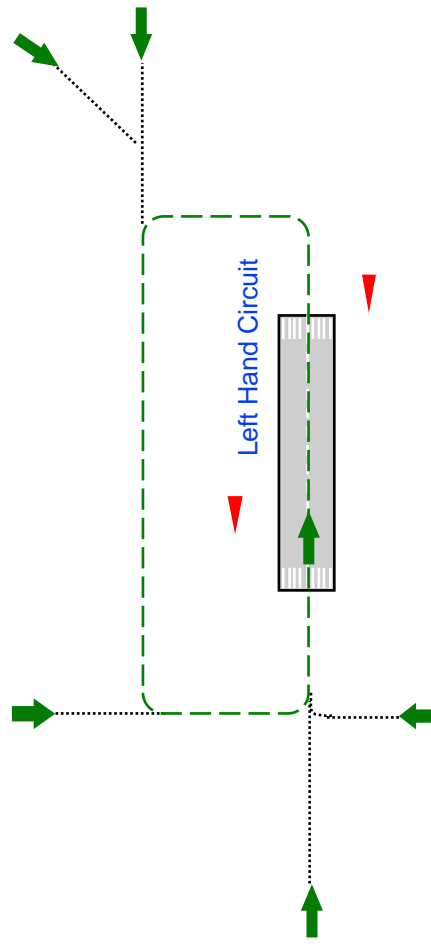

Radio Failure

Introduction

Although modern aircraft radios are reliable, the student needs to know what procedure to follow in the event of a communications failure. For this last reason, it is recommended that, once the standard overhead join procedure has been mastered by a student, simulated radio failure procedures should be taught before the student undertaking any training-area solo exercises.

When the student's home aerodrome is controlled, the CFI should provide guidance on what the student should do in the event of a radio failure outside the circuit.

Objective

To join at a controlled or uncontrolled aerodrome in the event of a radio failure.

Considerations

The student cannot enter a control zone without a clearance, so should the student break this rule or divert? Generally, ATC can be expected to accept an aircraft returning to the controlled aerodrome under these conditions, especially if the transponder code 7600 is used. However, if a diversion is required, training in this procedure will need to be given before solo exercises outside the circuit.

If a radio failure has occurred, it is unlikely to be detected until an attempt to make contact is initiated, for example, when tuning into the ATIS, or when requesting joining instructions. In the case of an uncontrolled aerodrome, where position and intentions only are transmitted, it may not be detected at all.

The **general** causes of communications failure are wrong frequency, on/off and volume switch, faulty headset connections, and popped circuit breaker. Others that may be applicable are the aircraft altitude and/or range (line of sight), alternator failure (although battery power should still be available and the alternator failure detected by other means), comm box switches not selected to headphones, radio loose in its cradle, or avionics master off.

Many modern radios can be tested for signal reception by selecting the test function and signal transmission confirmed by the small 'T' illuminating when the press-to-talk switch is depressed.

Aircraft Management

Before joining the circuit, the airspeed should be reduced to below 120 kts and landing lights turned on.

Preparing the aircraft for arrival is an aircraft management consideration and involves the use of the VFG, Visual Terminal Chart (VTC), and joining checklists.

The pertinent right-of-way rules are revised, and the requirement to make turns in the circuit direction emphasised.

Terminate your flight plan with ATC after landing.

Human Factors

The effects (ADVISE mnemonic) of **V**ision, **I**nformation processing and **S**tress are the prime considerations in this briefing.

The limitations of vision are revised in relation to closure rates and objects that do not produce relative movement. A very careful lookout will be required.

Information processing limitations and the use of mental models to retain situational awareness are discussed, thereby helping the student to draw a mental picture of the position of reported traffic.

Stress is reduced through compliance with a rule-based procedure and through practice.

Air Exercise

With a communications failure established, refer to the Visual Flight Guide (VFG) Emergency Section for the procedure to follow. Obviously it will be of some benefit to the student to have read this section before an in-flight communications failure. The main points of this procedure are:

- transmit blind (as all normal calls will be made, this action can be simulated)
- squawk 7600 (touch)
- turn on all lights
- use a cellular phone to communicate if available

Once a radio failure has been identified, the student should be instructed to **aviate** and **navigate**, remaining clear of controlled airspace, while a possible cause of the problem is investigated.

The various reasons for communications failure and the trouble checks will vary with the equipment installed. A separate briefing on the communications equipment installed and its correct use is recommended during circuit revision.

From the CFI's determination of procedure to follow in the event of a radio failure, choose from the two options below.

Uncontrolled Aerodromes

The join procedure is exactly the same as the standard overhead join, except that transmissions should be made 'blind'. A keen lookout for other traffic should be emphasised. If in any doubt, return to the orbit overhead at 1500 ft.

Radio failure is simulated and the trouble-shooting sequence or checklist carried out. Completing this sequence gives the student practice in prioritising – **aviate** – **navigate** – **communicate** and often demonstrates the limitations of information processing and the effects of stress. It is recommended that the student be given adequate practice in systems knowledge and fault detection **on the ground**.

With the radio failure established, the VFG, VTC, and checklist can be referred to and the communications failure procedure adopted.

Controlled Aerodromes

The student will need to know the meaning of the various light signals that will be used by ATC and how to respond to them.

Radio failure while in the circuit will also require knowledge of the light signals. Therefore, the meaning of light signals and how to respond is best covered in one of the pre-solo circuit revision briefings recommended earlier. The meanings and response need only be revised here by reference to the VFG.

With the radio failure established, the VFG, VTC, and checklist can be referred to and the communications failure procedure adopted.

Enter the control zone and carry out the standard overhead join procedure, watching out for the light signals and responding appropriately.

Report the communications fault to the control tower after landing.

RADIO FAILURE

OBJECTIVE:

To join at a controlled or uncontrolled aerodrome in the event of a radio failure.

CONSIDERATIONS:

Causes of radio failure

- wrong frequency selected
- ON/OFF switch
- faulty headset connection
- circuit breaker
- range
- alternator failure
- comm box switches
- radio loose
- avionics master off

Can you return to airfield?

- ATC will generally allow the return
- if need to divert - where do you go?

AIR EXERCISE:

1) Radio failure confirmed

refer to VFG Emergency section for procedures to follow

- transmit blind
- squawk 7600
- turn on all lights
- use a cell phone if available

2) Aviate - Navigate

Remain clear of controlled airspace while possible cause investigated

3) Proceeding to an uncontrolled aerodrome

Carry out Standard Overhead Join
Transmit blind

Lookout

4) Proceeding to a controlled aerodrome

Need to know light signals
Enter control zone
Carry out Standard Overhead Join
Watch for light signals and respond
Report comm failure to ATC once on the ground

AIRCRAFT MANAGEMENT:

120 Kts. Maximum circuit speed

Landing light on

Plan Ahead - rejoin checks

- pre-landing checks

All turns in circuit direction

Aircraft in circuit have right of way

Terminate flight plan after landing

HUMAN FACTORS:

Situational Awareness - chart W/V

Vision - **Lookout** & Listen-out

Info Process - attention, perception

Stress - systems knowledge
- rule based procedure
- regular practice

Forced Landing Without Power – The Pattern

This briefing primarily discusses the determination of wind direction, the selection of the most suitable landing site, and the pattern flown to achieve a successful forced landing.

Introduction

We have already discussed the main reasons for engine failure (these may be revised: fuel, air, spark – OHP recommended) and how sensible precautions can minimise risk (these also may be revised: preflight inspection and planning, run-up, DVAs, safety brief, SADIE – OHP recommended).

In addition, the student is familiar with overlearning a procedure to produce an automatic response in emergency situations.

This lesson discusses the ideal procedure to follow in the unlikely event of a total or partial engine failure in the cruise at altitude (above 1000 ft agl **as a guide**) where more time is available to plan and consider options than the EFATO. Later exercises will provide practice in adopting this procedure from a less-than-ideal situation.

A partial engine failure or rough running is more common than a total failure, but this is still rare. The recommended procedure for dealing with the partial power failure begins with the same steps as a total failure, and therefore the **pattern** is relevant to both. The specific considerations of having partial power available will be discussed in a later lesson.

A total power failure will be simulated by closing the throttle, thereby leaving power available at any time it is needed.

Objective

To carry out the recommended procedure in the event of a total or partial engine failure above 1000 ft agl.

Considerations

Configuration

The configuration required to achieve the best L/D ratio for the aircraft is stated (___ kts, no flap and propeller windmilling) and its effect on range. The effect on range of using other airspeeds will be discussed in the forced-landing-without-power briefing.

Although drag is reduced by stopping the propeller, this procedure is **not recommended** (refer CFI). To do so requires the aircraft to be brought close to the stall, and it is dubious whether the reduction in drag will compensate for the altitude lost in the subsequent recovery to best glide speed. In addition, this procedure cannot be practised safely, and it would increase stress, limiting the pilot's information processing capabilities at a critical time.

Wind Indicators

The various methods of determining the wind speed and direction are discussed, with emphasis on direction because the **plan** is based on wind direction – not speed.

The most reliable indicators are those at ground level: smoke, dust, crop movement, or wind lanes and wind shadow on water.

Smoke

Smoke is the best indication of wind direction and strength.

Dust

Dust from dirt roads or ploughing, as well as ground spread fertiliser, may indicate wind direction and strength.

Crop Movement

Ripples move downwind across the top of crops, especially wheat fields.

Wind Lanes

Wind produces effects on the surface of the water. Light winds, 5 to 15 kts, can ruffle the surface and, when viewed up or down wind, these disturbances form streaks of parallel lines, indicating the wind direction – but it can be difficult to resolve the 180-degree ambiguity.

Above 15 kts, the wind may drive spray or foam in parallel lines. These too can be misinterpreted by 180 degrees, although the streaking may be more marked when looking downwind compared with the upwind.

Waves and Ripples

Waves and ripples form at right angles to the wind and move downwind. The first whitecaps appear between 7 and 10 kts. From altitude, however, it may be difficult to determine the direction of wave movement.

Wind Shadow

Wind shadow is the result of water at the upwind shoreline being protected by the shoreline, creating an area of calm water. This effect is most noticeable in winds of 5 kts or more, when the sunlight reflects off the water's surface. A small version of this can be seen as you walk out to the aircraft after rain. Puddles of water lying on the tarmac will display this same effect when the wind is blowing. Wind shadow is best seen on small ponds or lakes rather than large expanses of water.

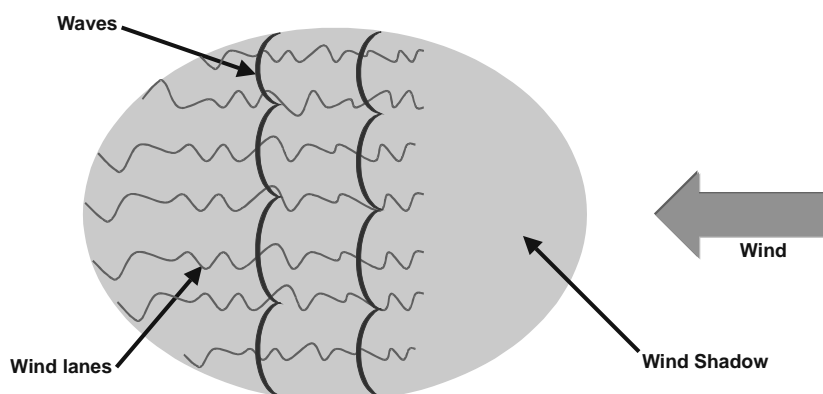

Both smoke and wind shadow on water should be observed in flight at all times and this information used to promote situational awareness.

The next best indicators of wind direction are upper air indicators: cloud shadow, the 2000-ft wind (ATIS), area-forecast wind, and drift.

Cloud Shadow

The movement of cloud shadow over the ground gives the wind direction and some indication of speed, at the cloud level. This is used only as a guide, however, as the wind at ground level may be different. Likewise, the 2000-ft wind and area forecasts are only a guide to the wind's general direction and strength when planning a forced landing.

Drift

Drift is the least useful as it can be difficult to see at altitude unless very strong winds are present. It can also be apparently induced, by flying out-of-balance.

Local Knowledge

The other means of determining wind direction and strength are related to local knowledge and the aerodrome of departure, for example, the windsock and the known takeoff direction. The usefulness of these indicators is relative to the distance of the aircraft from the aerodrome – and the intervening terrain.

Choice of Landing Site

The choice of the most appropriate landing site is usually a compromise and is discussed using the mnemonic ***the six S's and the BIG E***.

The six S's are: Size, Shape, Slope, Surface, Surrounds and Sun. The big E is for Elevation.

Size

The ideal is for the longest possible landing area **into wind**, within easy reach (to be discussed further in considerations).

Shape

Shape is mentioned because the student may limit their search for a landing site to **only** those sites that resemble a runway. In fact, the perfect shape is a circle, as multiple approach paths into wind are available. Even a square is preferable in contrast to a narrow paddock with only one approach path.

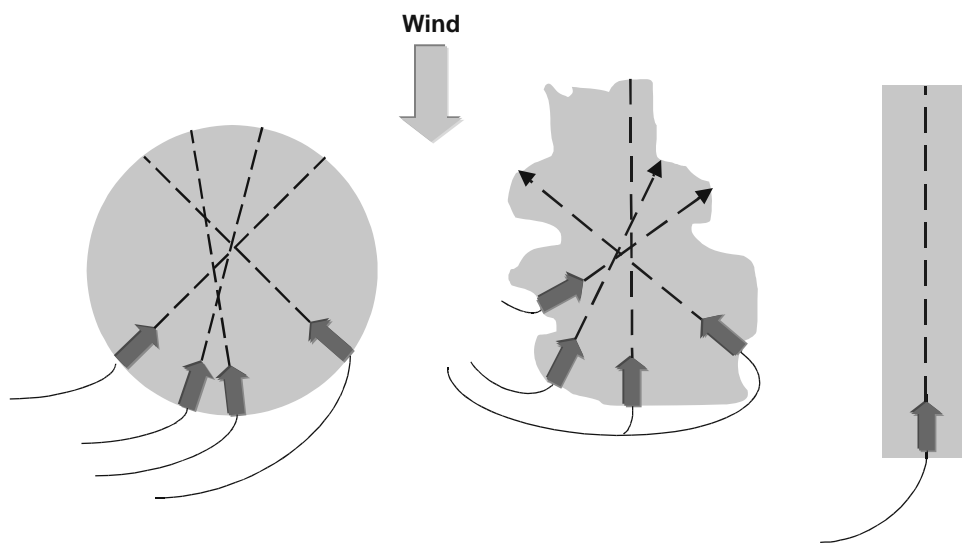

Slope

An uphill slope for landing is preferred over level ground. A down-slope is avoided, unless the wind strength negates the disadvantages of a downhill landing. Slope can be difficult to detect at altitude, and when slope is apparent from altitude, generally the terrain is very steep. However, water runs downhill, so creeks that narrow give some indication of slope (ie, they are narrow at the higher end) and the dam wall on farm water storage ponds also indicate downhill slope.

Surface

A firm surface is recommended, not so much for stopping distance as to avoid the nosewheel digging into a soft surface and somersaulting the aircraft. Determining the type of surface

from altitude can be done by comparing the texture of the local aerodrome's grassed areas with those of various paddocks.

Surface also includes anything on the surface, such as stock, crops, fences and stumps.

Surrounds

Where possible a landing site that has a clear field on the approach end **and** the upwind end is chosen to provide for undershoot and overrun during the forced landing. For the training exercise, a clear go-around and climb-out path is also considered.

Sun

Sun is normally only a problem at sunrise and sunset. Under these conditions an approach in the direction of the sun may blind the pilot on final.

Elevation

Based on local knowledge, charts or comparing the altimeter reading with terrain perspective, the height above sea level of the landing site needs to be estimated. This is because the procedure is **planned** on heights above ground level but **flown** on heights above sea level with reference to the altimeter.

Situational Awareness

The ability to quickly implement the forced-landing procedure is markedly enhanced by good situational awareness. Throughout the flight the pilot should observe wind indicators and the approximate elevation and suitability of the surrounding terrain. This does not require the pilot to choose a specific forced-landing site and update it continuously in cruise. Through situational awareness the pilot should know where the wind is coming from and where in relation to the aircraft, the more suitable terrain is for a forced landing. Should an emergency develop, an immediate turn toward this area is made and **then** a specific field chosen.

Aircraft Management

The engine failure will be simulated from _____ ft by closing the throttle. The first demonstration/patter and student practice should be conducted at a suitable altitude so as to reduce the student's stress and to aid information processing.

As a prolonged climb will be required before commencing the exercise, a period of level flight is recommended to allow the engine temperature to stabilise before closing the throttle.

To close the throttle before selecting carb heat hot (for a prolonged glide) is poor aviation practice, but if you select hot air before closing the throttle, the student will often not manipulate the carb heat control during the subsequent checks. Some instructors feel the risk is acceptable and close the throttle, leaving the student to select hot air during the checks. The compromise method recommended here is that you select hot air and then close the throttle, with the student briefed to cycle the carb heat (cold then hot again) during the checks (refer CFI). Although selecting carb heat will warn the student of what is to come, it should be borne in mind that the objective of the exercise is not to test reaction time, but to ensure that the student has learnt the procedure to adopt. Therefore, the good aviation practice considerations of selecting hot air, verbally stating "simulating" and smoothly closing the throttle, have no direct bearing on the successful completion of the exercise.

To maintain adequate engine operating temperatures and pressures during the prolonged glide, the engine is **warmed** or **cleared** every 1000 ft (minimum) by smoothly opening the throttle to full power and closing it again. This ensures that normal power will be available for the go-around, clears the spark plugs of lead/carbon deposits and puts warm air through the carburettor, preventing ice build-up. If the engine runs rough during the engine warm, consider warming or clearing more often (every 500 ft), delay closing the throttle again until smooth running is achieved, or begin the go-around immediately or at a considerably higher altitude than the minimum. This will depend on the engine's running characteristics and the terrain.

There is no need to select carb heat cold during the engine warm as no attempt is being made to continue using full power. In addition, the effectiveness of the carb heat is dependent on engine temperature, and the application of full power will ensure carb ice is cleared.

Revise touch checks (any check that would be carried out in the event of an actual engine failure, that it is not recommended to carry out during the simulation) and write in red under air exercise.

The simulation is ended with the instruction “Go-around”, at which point the student is to immediately carry out a go-around. In later lessons more emphasis will be placed on the student’s decision-making to initiate the go-around without prompting.

The student should be advised that, although this exercise may be carried out solo, it is illegal to carry passengers during forced-landing practice.

Unless operating in a Low Flying Zone, the go-around will start at not less than 500 ft agl.

Human Factors

The effects (ADVISE mnemonic) of **D**isorientation, **I**nformation processing and **S**tress are the prime considerations in this briefing.

Disorientation is minimised through the selection of prominent landmarks during the planning stage of the descent. Avoid turning your back on the chosen landing site.

Information processing is enhanced through situational awareness and inhibited by stress.

Stress is minimised through adopting a procedural response to the unexpected, and by regular practice.

Air Exercise

The exercise starts from an appropriate cruising altitude (refer supervisor), not a height above ground level, as the aircraft is normally flown by reference to the altimeter.

The initial actions, planning and flying the procedure are discussed.

Aviate

Immediate Actions

Convert excess speed to height. Since there **may** be an appreciable difference between the cruise speed and the recommended glide speed, the correct procedure is to initiate a zoom manoeuvre to gain extra height. For the average modern light aircraft this is a **gentle** manoeuvre and may result only in **maintaining** height for a short period.

As the best glide speed is approached, allowing for inertia, the attitude is selected for the glide and the aircraft accurately trimmed to maintain this attitude.

Trimming accurately reduces the pilot’s workload and therefore improves information processing.

Trouble Checks

F – Fuel pump on, change tanks (touch). Since fuel is the most common cause of engine failure it is the first to receive attention.

Refer to the aircraft Flight Manual for the appropriate sequence. The changing of fuel tanks is a touch check because, before the simulated failure, fuel is known to be feeding from the selected tank. If a different fuel tank is selected and for some reason fuel is not feeding from the newly selected tank, this will not be discovered until the first engine warm 1000 ft lower than the starting height.

An unlocked primer is commonly associated with a partial power failure rather than a total power failure, so primer appears in the trouble checks rather than the initial actions.

M – Mixture rich, carb heat HOT (cycle). The fuel air mix is the next most common cause of engine failure.

I – Ignition on both (touch).

Trying left (touch) and right (touch) magneto positions for smoother running is associated with the partial power failure and is therefore part of the trouble checks rather than the initial actions.

P – Partial power, set the throttle to about one third open to ascertain how much power, if any, is available. If no power is available, the throttle must be closed again so as to prevent the engine unexpectedly bursting into life at an awkward moment. In the simulated exercise the partial power check serves to warm the engine.

Navigate

If situational awareness has been maintained, the approximate elevation of surrounding terrain and the wind direction are known. The aircraft is turned toward the most suitable area for a forced landing. It should be stressed that – if situational awareness has not been maintained – valuable time will be wasted while these factors are assessed.

The Plan

A **specific** landing site or the best compromise is now chosen, with reference to factors determining field selection, and the approach planned.

Planning the approach begins with selecting a minimum of three references: an aiming point $\frac{1}{3}$ into the field in the landing direction; a 1000-ft agl area; and a 1500-ft agl area. The aim is to fly the approach as similar to a lefthand circuit as possible.

The selection of references begins at the ground and works up to save time, because, if the aircraft was flying at 1500 ft agl at the time of engine failure, there is little point in choosing a 1500-ft area.

It **must** be stressed that the 1000-ft and 1500-ft references are above ground level, and that these provide valuable orientation information if the landing site is lost from view.

Some organisations recommend an additional 2000-ft agl area (refer CFI)

When the considerations of a righthand circuit are introduced (refer CFI), the plan is simply flipped over, like the page in a book, to produce a mirror image on the righthand side of the landing site.

The first step is to **divide the available landing distance into three** and choose a definite reference or aiming point at about $\frac{1}{3}$ into the field. The logic behind this is that it is better to taxi, even at high speed, through the far fence than to fly into the first or threshold fence.

Although a positive reference point on the field is best, it does not have to be in the field itself, but can be abeam the $\frac{1}{3}$ aiming point, one or two paddocks over.

The 1000-ft area (shown as low key on the whiteboard layout) is at 90 degrees or right angles to the threshold between a normal circuit distance out and a little closer, usually $\frac{3}{4}$ of the normal circuit distance out (refer CFI). This area is about 4000 sq m, ie, the size of a block of four to six suburban residential sections.

The distance of this point from the field is critical in that there is a natural tendency to hug the field, resulting in a very tight turn to final and little or no opportunity to adjust the approach. The downwind leg should **never be closer than three-quarters of a normal circuit spacing**.

The 1500-ft area (shown on the whiteboard layout) is a larger area further back from the 1000-ft area.

From anywhere within this area, at 1500 ft agl, it will be possible to glide to the 1000-ft area and arrive at about 1000 ft agl.

The next step in the planning process is to transform the 1000-ft and 1500-ft areas into altitudes that will be seen on the altimeter, by adding on the estimated elevation of the chosen landing site.

It will be shown how the downwind spacing compensates for any error in the estimate of elevation. A point worth making here is that it is **always** better to overestimate than underestimate and that if there is any doubt, add two or three hundred ft onto the estimate of the landing site elevation.

The most important part of the plan is assessing progress into the 1500-ft area from wherever the aircraft happens to be.

The **ideal** procedure starts from the non-traffic side, flying parallel to the chosen landing site.

The positioning process is assisted by asking **at regular intervals**, “am I confident of reaching the 1500-ft area at _____ ft?” If any doubt exists, a turn toward the area should be started immediately. If no doubt exists, the turn can be delayed.

During the intervals, checks, to be discussed in the next briefing, would be carried out.

Once the 1500-ft area has been passed, the aircraft is positioned on the downwind leg.

Critical Action

On the downwind leg it is vital that the spacing is assessed in relation to the nominated point on the aircraft airframe to establish the correct circuit spacing. It is this process which compensates for any misjudgement in the height that the 1500-ft area was entered at, and any error in estimating the landing-site elevation.

The diagram below is only an **example** of how spacing is assessed using the parallel markings on the wing of this aircraft.

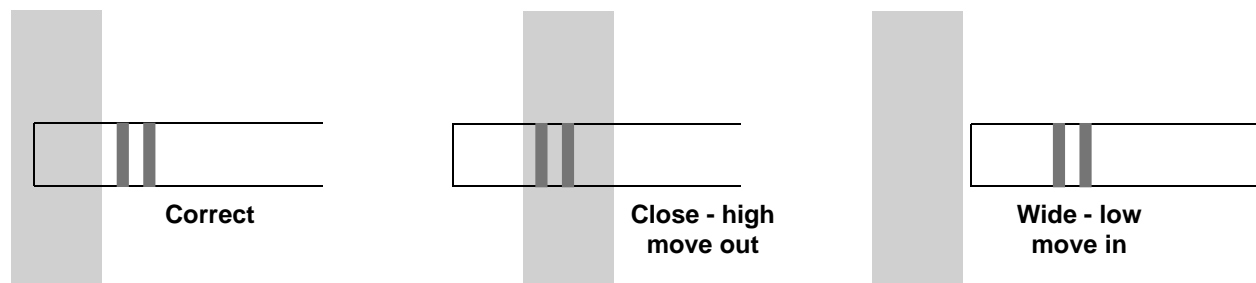

The student should use a model aircraft and place it on the drawn landing site at the chosen downwind spacing.

By lifting the model aircraft off the diagram and looking across the model, while aligning the airframe feature with the landing site, you can show that the aircraft is now too close or high. The student must move out from the landing site to once again position the airframe feature onto the diagram.

Lowering the model will have the reverse effect (too wide – low) when sighting across the model, and force the student to move in toward the diagram to re-establish the correct spacing.

At the 1000-ft area, abeam the threshold, the approach phase starts.

NEVER EXTEND 1000-FT AREA DOWNWIND

It now depends on the wind strength how soon the base turn is started. Strong wind, turn sooner. Light winds, turn later.

The aircraft should be turned to track on base leg at 90 degrees to the landing direction.

From the base leg, further adjustments can be made if necessary. If the approach appears too low, the turn onto final can be made early. Conversely, if too high, either widening the turn or extending the base leg, can be carried out.

Throughout the approach, from the 1000-ft area down to approximately 500 ft agl, continual reference is made to the $\frac{1}{3}$ aim point and to maintaining glide speed. No checks are carried out during this segment.

It is very important to offset drift during the base leg, so as to ensure that the aircraft **tracks** correctly in relation to the field.

Judgement of the approach is facilitated by **repeatedly** asking, “can I reach the $\frac{1}{3}$ aim point – yes/no?”

In extremely strong winds, or if a headwind is encountered on base, this may require the aircraft to be turned to point directly to the $\frac{1}{3}$ aim point.

The aim of this process is to position the aircraft at **about** 500 ft, so as to touch down at the $\frac{1}{3}$ aim point, **preferably** without flap.

This is not a restriction but the preferred configuration. If there is a need to use flap earlier, because you are grossly high, then flap is used. However, it will be shown during the glide approach that flap is one of the options available to bring the actual landing point back toward the threshold from the $\frac{1}{3}$ aim point, so as to make maximum use of the ‘runway’ length available. If flap is being used during the base turn to reach the $\frac{1}{3}$ point, this option is negated.

Note that some organisations may teach variations on the approach phase of this exercise (refer CFI).

Airborne Sequence

During the climb and transit to the training area, point out the various wind indicators and surface types (ploughed, swampy). Also, give the student some opportunity to practice estimating the elevation of various landing sites.

Never estimate the height of the landing site as zero, even if it’s a beach. This is especially important if practice is often carried out in low-lying areas. Emphasise that the plan is based on agl by estimating the height of the beach as 50 or 100 ft. This over estimation is easily compensated for.

Before starting the exercise, **all** available indicators of wind should be observed or discussed, the initial forced-landing site pointed out, and the student asked to estimate its elevation.

The various reasons for choosing the landing site are discussed in relation to the 6 S’s.

The **introduction** to forced landing without power is never carried out onto an aerodrome or agricultural airstrip. This is because a major part of this exercise deals with assessing the wind without a windsock or known active runway and the suitability of the landing site, which is not a designated landing area. In addition, all airfields attract aircraft and have an aerodrome traffic pattern around them, requiring radio calls to be made for the information of other traffic. Even if you carry these out, they form a distraction to the lesson.

The planning process is next discussed. Choosing the $\frac{1}{3}$ aim point, 1000-ft area, the 1500-ft area, and modifying these to altitudes.

Throughout this process, the chosen landing site is kept on the left of the aircraft (student’s side) and the aircraft is held in a gentle level turn so that the landing site can be continually observed.

The novice instructor often makes two common errors.

1. Getting too close to the landing site, requiring large angles of bank or flight out of balance to observe the field. At the heights commonly used to start this exercise, the aircraft needs to be at least 2 NM away from the field (at least twice circuit spacing).

2. Not allowing for drift during the gentle turn to observe the landing site - a constant radius turn is required to maintain a constant distance.

Before the throttle is closed to simulate the engine failure, all the considerations of wind, elevation, landing site and reference points are discussed. The aim is to demonstrate the **ideal** forced-landing pattern, and later exercises will require the student to adapt this pattern for the conditions under which the power failure is simulated.

The value of the demonstration/patter will be negated if the student is not aware of which landing site is being used and what features define the $\frac{1}{3}$, 1000-ft and 1500-ft references.

This exercise **may** be started with a demonstration involving **all** the checks that would be carried out. It is recommended, however, that the exercise begin with the initial actions and a demonstration/patter. This should consist of how the aircraft is being positioned for the 1500-ft area, the use of spacing downwind to make the 1000-ft area, and how to fly the base leg to make the $\frac{1}{3}$ aim point.

The two most important functions in any emergency are **aviate – navigate**. Therefore, regardless of whether a demonstration including checks is given or not, a demonstration/patter without checks emphasising **how** the aircraft is positioned into the 1500-ft area and onwards **must** be given.

The aircraft is positioned on the non-traffic side of the chosen landing site, facing into wind, preferably at least 2500 ft above ground level to give information-processing time. Closing the throttle is at your discretion so, once all relevant points about the approach have been observed by the student, position the aircraft appropriately.

Carb heat is selected hot, the throttle closed and the initial actions carried out (including cycling the carb heat). Except for the regular engine warm, no other checklists are completed.

Throughout the approach you should draw the student's attention to the relevant features. The 1500-ft area is relatively easy to achieve because it is such a large area, and the 1000-ft area cannot be missed if the spacing is correct. Problems invariably arise in the judgement of the approach to the $\frac{1}{3}$ aim point. This is because the student has spent several hours in the normal circuit, and all their experience in judging an approach has been in relation to a threshold or runway end. It is vital, throughout the base, that you repeatedly draw the student's attention to the $\frac{1}{3}$ aim point and ask if the student is confident of placing the aircraft wheels on the ground at that point.

Judgement of whether the $\frac{1}{3}$ aim point can be reached or not is facilitated by maintaining a constant airspeed and noting whether the aim point moves up the windscreen, down the windscreen, or remains constant.

At this point the objective of this exercise has been achieved. The measure of success is whether or not the $\frac{1}{3}$ aim point could be easily reached from this position. Regardless of the answer to that question, you tell the student to go-around. You or the student must assess whether an earlier go-around is advisable due to turbulence, terrain, stock or nearby habitation.

The aircraft should be repositioned into the ideal forced-landing start position using the same landing site for student practice.

The student should be encouraged to verbalise their level of confidence on reaching the 1500-ft area and the $\frac{1}{3}$ aim point. If not, you may need to prompt the student with questions of confidence level and appropriate action, especially if you doubt the aircraft's ability to reach the nominated references.

Do not use terms such as:

1. “This approach looks high/low/correct.”

Emphasise **what** the student should be looking at, to judge the approach: “This approach looks high in relation to the water trough [$\frac{1}{3}$ aim point].”

2. “Delay flap until you’re sure of getting in.” You could be “sure of getting in” from 3000 ft agl over the landing site!

Emphasise, “Delay flap to **about** 500 ft agl and ensure the water trough [$\frac{1}{3}$ aim point] can be reached.” Provide for exceptions, by stating that “If flap is needed then use it.”

3. “Can you make/reach the field?” This draws the student’s attention away from the $\frac{1}{3}$ aim point to look at the overall landing site. Students who go high/overshoot are usually doing this. Students who go low/undershoot are **always** looking at the threshold.

Emphasise the $\frac{1}{3}$ aim point, eg, “Can you reach the water trough?”

Where possible, this exercise concludes either with a demonstration forced landing onto the home aerodrome, or the student is encouraged to fly the pattern down to about 500 ft agl, where you take control and demonstrates how the aiming point is brought back toward the threshold through the use of flap. During the latter exercise, you make all radio calls so that the student can concentrate on the pattern. Maintain situational awareness and **beware of other traffic**, as a simulated forced landing does not give you automatic right of way.

The handout on this lesson should include a complete set of checks to be learnt before the next lesson.

FORCED LANDING WITHOUT POWER -THE PATTERN

OBJECTIVE:

To carry out the recommended procedure in the event of a total or partial engine failure (above 1000' AGL).

CONSIDERATIONS:

CAUSES	(OHP)	AVOID BY
Fuel - contamination, starvation, exhaustion Carburettor icing, blockage Mechanical failure		Pre-flight checks, Run up, In flight management, SADIE, Situational awareness, Systems knowledge

Airspeed Best glide speed ___ kts (flaps up, prop windmilling)
Best lift / drag ratio - Max range in still air conditions

Wind Direction

- **at ground level**
- smoke, dust, crops, wind lanes/shadow
- **at upper levels**
- cloud shadows, forecasts, drift
- **through local knowledge**
- windsock, known take-off direction

Field Selection - **6 'S'** + the big **E**

Size, Shape, Slope, Surface, Surrounds, Sun, Elevation

MAINTAIN SITUATIONAL AWARENESS

AIRCRAFT MANAGEMENT:

- Simulated** - by closing throttle Allow T's and P's to stabilise
- Carb Heat - Hot - Cycle
- Clear engine every 1000' min.
- Touch Checks
- "Go-around" - ends simulation
- No Pax when practicing**
- Not below 500' AGL solo**

HUMAN FACTORS:

- Disorientation**
- Prominent landmarks
- Info Processing**
- Improved by **Situational awareness**
- w/v, elev, terrain
- Inhibited by **Stress**
- Procedural response
- Regular practice
- Overlearning

AIR EXERCISE:

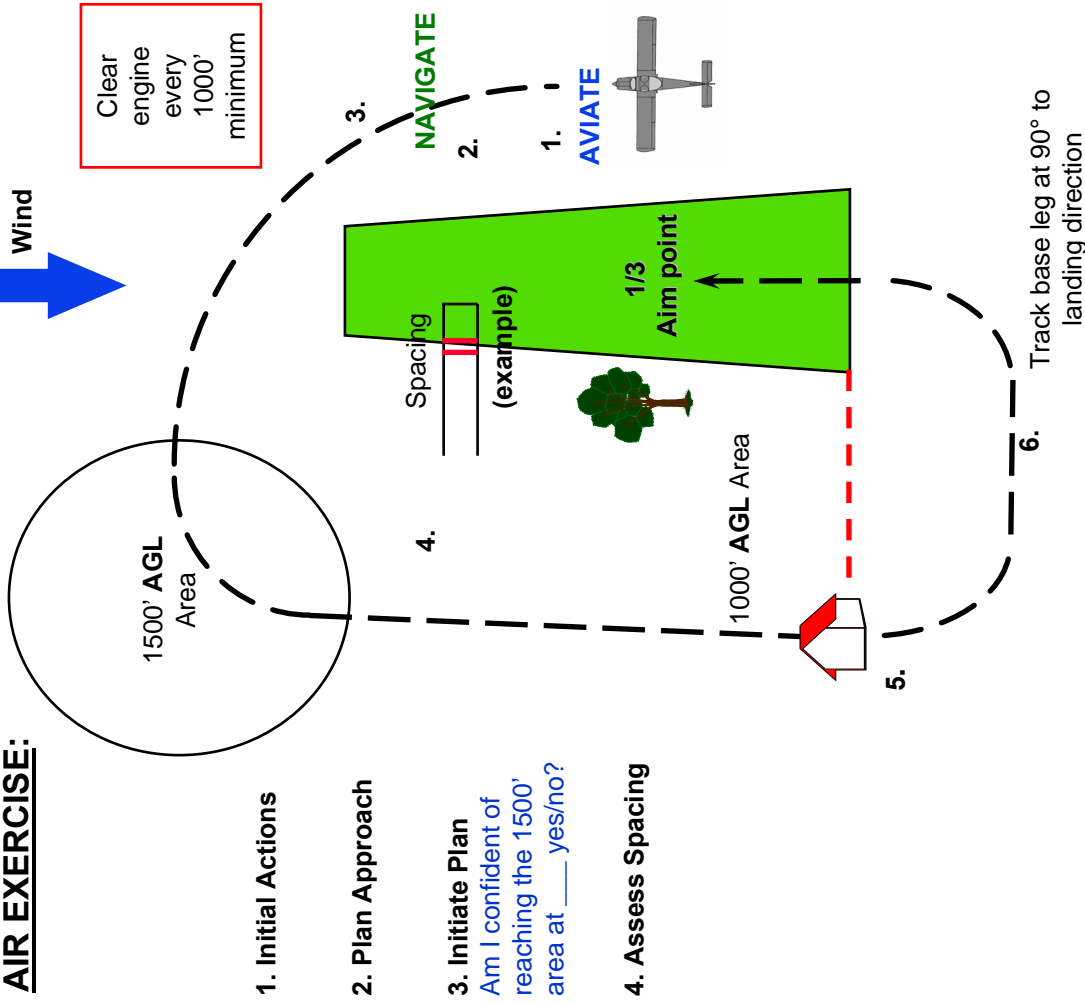

1. Initial Actions

2. Plan Approach

3. Initiate Plan
Am I confident of reaching the 1500' area at ___ yes/no?

4. Assess Spacing

- 5. Commence turn onto base - NEVER EXTEND 1000 FT AREA DOWNWIND**
- 6. Assess the approach**
Can I reach the 1/3 aim point - yes/no? (Min. 500' AGL overshoot)

Forced Landing Without Power – Considerations

This lesson revises the recommended procedure for carrying out a forced landing without power. The appropriate checklists are inserted, and the considerations that may have some bearing on decision-making are discussed.

Introduction

As the student becomes more familiar with the forced landing pattern, and overlearning the initial actions and planning process in order to minimise stress, spare information processing capacity becomes available.

This spare capacity can be used to complete recommended checklists and consider various factors that may affect the recommended pattern. However, aviate - navigate remain the prime considerations of any emergency. Where stress levels are high, always revert to aviate first, navigate second, and use only spare capacity for anything else.

This lesson looks at how any spare capacity during a total engine failure can best be utilised and the considerations of a partial power failure.

Objectives

1. To carry out the recommended procedure in the event of a total or partial engine failure, incorporating the appropriate checklists.
2. To implement aeronautical decision-making (ADM) as a result of a partial power failure.

Considerations

The probable causes of engine failure are revised, and the methods of avoiding this occurrence are emphasised (refer Campbell¹⁴⁵). An OHP is recommended.

The various factors affecting gliding range are discussed. The effects of L/D ratio, altitude and wind are relevant to the first requirement of landing site selection – that the site is within easy reach.

Best L/D

In a glide the weight is supported by the resultant of lift and drag. The angle between this resultant and lift is the same as the glide angle. Therefore, if this angle can be reduced, the glide angle will be reduced, and the glide will be shallower, and thus the aircraft will glide further (in nil wind).

There are two ways to decrease this angle. If the lift could be increased and the drag kept constant, a smaller angle would be formed. Or, if the lift remained constant and the drag was reduced, a smaller angle would be formed. Since it is not possible to have lift without drag, the smallest angle will be formed when the lift is greatest and the drag is least. This occurs at the best lift/drag ratio.

When the aircraft glides in the configuration for the best L/D ratio (___ kts, no flap, propeller windmilling), the angle of attack is about 4 degrees, the smallest glide angle is achieved, and the range is greatest.

¹⁴⁵ 1994, p.17-19

If the nose attitude is lowered, to glide at a higher airspeed, the range will be reduced. If the nose attitude is raised, to glide at a lower airspeed, the range will be reduced.

The visual illusion created by raising the nose – trying to stretch the glide – will require careful explanation.

Although raising the nose can make it look like the aircraft will reach a more distant field, the aircraft sinks more steeply than when at the best L/D ratio.

With the aircraft trimmed to maintain an attitude for the best L/D ratio, if the reference area or point does not move down the windscreen, or at least remain constant – it **cannot** be reached.

The gliding abilities of aircraft vary but, for the average light training aircraft, within easy reach is commonly described as: look down at an angle of about 45 degrees and scribe a circle around the aircraft; anything within the circle is within easy reach.

Height

The size of the circle will obviously be affected by height.

Therefore, the third of the three most useless things to a pilot is introduced: **sky above!**

Never fly lower than you must!

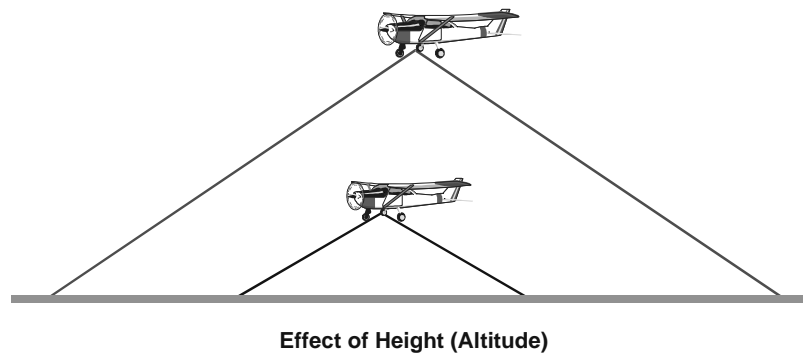

Altitude (height) will also affect the amount of time available for planning and completing the recommended checklists.

Wind

The glide range is increased by a tailwind and reduced by a head wind. Therefore, the effect of wind on range will be to elongate the circle downwind, producing more of an egg shape than a circle.

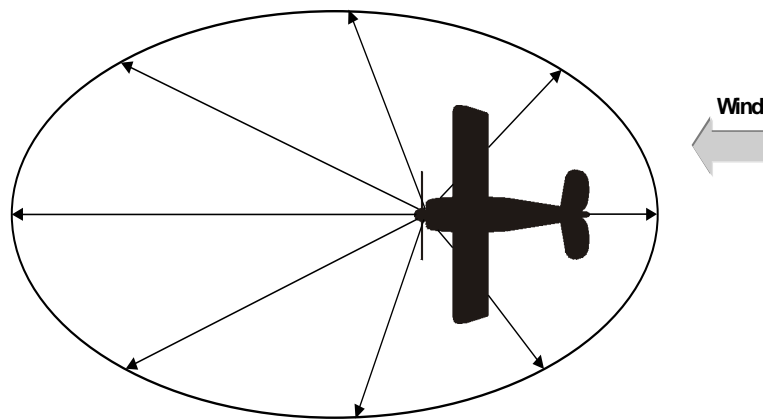

If an engine failure occurs while flying over terrain where no suitable landing sites are available, it **may** be advantageous to turn downwind. This increases the glide range and therefore, the choice of landing sites.

Partial Power

At the completion of the trouble checks, a check for partial power is made by opening the throttle to full power. If there is no response the throttle is closed and the forced landing without power continued.

However, if some power is available, for example, 1800 rpm at full throttle, a range of choices becomes available. These will require the application of aeronautical decision-making and pilot judgement.

The first decision to be made is whether to continue with the forced landing by closing the throttle, leaving the engine at idle and not relying on the available power. The alternative is to use the available power to transit to a more suitable landing site. This decision must be made with the knowledge that a partial power failure may become a total power failure at any time.

Other factors that will affect the decision are:

- The suitability of the nearest landing site.
- The amount of power available. For example, is there sufficient to fly level at not less than the endurance speed or is a gradual descent required to maintain airspeed?
- The type and height of terrain to be crossed in transiting to a more suitable landing site. For example, will flight over a built-up area be required, or can leapfrogging from landing site to better landing site be accomplished?
- The cause of the power reduction (if known). For example, no oil pressure and reduced power can reasonably be expected to quickly become a total power failure.
- The aircraft altitude: **Never fly lower than you must.**

Aircraft Management

The engine failure will be simulated from ____ ft by closing the throttle. Ensure there is sufficient height to complete the checklists without undue haste during early student practice.

Stabilise the engine temperature before commencing the exercise.

Revise touch-checks, written in red.

Revise the engine warm (every 1000 ft minimum).

A pre-flight passenger brief is used to describe the type and location of emergency equipment on board, and the method of getting out of the aircraft in the event of a forced landing. Time spent here (on the ground) reduces the time required to explain these points in the event of an emergency, and it improves the passenger's situational awareness¹⁴⁶.

The student should initiate the go-around without prompting at **appropriate height** (refer CFI). However, if at any time the instruction to go-around is given, the simulation is ended.

The student should be reminded that, although this exercise may be carried out solo, it is illegal to carry passengers during forced-landing practice.

In later lessons, this procedure may be carried out onto aerodromes so that the glide approach can be incorporated and the complete forced-landing procedure practised. However, the student should be aware that simulated forced-landing practice does not provide the right-of-way.

Human Factors

The effects (ADVISE mnemonic) of **D**isorientation, **I**nformation processing and **S**tress are the prime considerations in this briefing.

Disorientation is minimised through the selection of available prominent landmarks during the planning stage and regular monitoring throughout the approach. Do not concentrate on the checklists at the expense of the pattern.

Information processing is enhanced through situational awareness and checklists.

Stress is minimised through adopting a procedural response to the unexpected, regular practice (overlearning) and pre-flight planning (passenger brief).

Air Exercise

The initial actions are completed:

AVIATE

- **Convert excess speed to height**, throttle set to one third open (touch), check behind the aircraft for smoke.
- **Fuel pump ON, change tanks** (touch). Refer to the aircraft Flight Manual for the appropriate sequence.
- **Mixture RICH, carb heat HOT** (cycle).
- **Ignition, on BOTH** (touch).

As the best glide speed is approached (allow for inertia), the attitude is selected for the glide and the aircraft trimmed.

NAVIGATE

Stress situational awareness; the elevation of surrounding terrain and wind direction should be known (approximately) at all times.

¹⁴⁶ NZ Flight Safety, 1986, pp.17-19

Choose a **specific** landing site with reference to factors determining field selection, and plan the approach.

Initiate the plan. The most important part of the plan is assessing progress into the 1500-ft area from wherever the aircraft happens to be! “Am I confident of reaching the 1500-ft area at _____ ft?” If any doubt exists, a turn toward the area should be immediately started. If no doubt exists, the turn can be delayed.

Carry out the **trouble checks (FMI)**. This is a more thorough check than the initial actions.

F – Fuel pressure, contents and tank selected. Fuel pump on, fuel pressure and the contents gauges are checked and compared with the fuel tank selected. Primer locked.

M – Mixture RICH, carb heat HOT. These are rechecked and the mixture, in the case of partial power, altered (touch) to see if there is any improvement in power or smoothness.

I – Ignition on BOTH (touch). Try left (touch) and right (touch) magneto positions for smoother running (partial power) and **Instruments**, check temperatures and pressures for indications of cause.

The starter is engaged only if the propeller is not windmilling.

Check for power. Assuming no response, close the throttle. For the exercise, this check for power serves as the first engine warm.

At the end of this exercise, a partial power response will be simulated and ADM considerations discussed.

Assess the Approach. “Am I confident of reaching the 1500-ft area at _____ ft?” If any doubt exists, a turn toward the area should be immediately started. If no doubt exists, the turn can be delayed.

COMMUNICATE

Transmit MAYDAY (touch). The mayday transmission is next because height is being lost, reducing the effective radio range (line of sight). Normally this transmission is made on the frequency in use. However, if there is no response, or the frequency in use is considered inappropriate (for example, 119.1 aerodrome traffic), a change to 121.5 (touch) should be made and 7700 (touch) selected on the transponder.

Where an Emergency Locator Transmitter (ELT) can be activated remotely from the pilot’s seating position, the ELT is selected ON (touch).

Assess the approach. “Am I confident of reaching the 1500-ft area at _____ ft?” If any doubt exists, a turn toward the area should be immediately started. If no doubt exists, the turn can be delayed.

Brief the passengers. Valuable time can be saved here if a thorough briefing of the emergency equipment and exits has been given before flight¹⁴⁷.

If time permits, the chosen landing site and the direction of the nearest habitation that may be able to provide assistance after landing should be pointed out to the passengers.

Exits are unlocked (touch if applicable), but normally left latched. Depending on aircraft type, exits may be jammed partially open with the dipstick or VFG. This prevents the doors

¹⁴⁷ NZ Flight Safety, 1983/84

from jamming closed should the aircraft impact an object on landing or somersault. However, it may also weaken the airframe – or it may not be permitted in flight (refer aircraft Flight Manual and CFI).

Checks for loose objects and secure harnesses are made, and all sharp objects, pens, glasses and dentures (touch!), removed.

The passengers are also reminded to adopt the brace position on short final and are given a meeting point. The meeting point is nominated in relation to the aircraft or some prominent ground feature. It is usually ahead of the aircraft (upwind), assuming a landing into wind. This is to minimise the risk of burns should fire break out.

Assess the Approach. The downwind leg starts from the 1500 ft area. It is vital that on the downwind leg the spacing is assessed in relation to the nominated point on the airframe to establish the correct circuit spacing. **Secure the aircraft (FMI).** These checks take the place of the normal pre-landing (downwind) checks.

F – Fuel. OFF (touch).

M – Mixture. IDLE CUT OFF (touch).

I – Ignition. OFF (touch).

These checks are carried out to minimise the risk of fire. In addition, the master switch should be turned off (touch) to isolate electrical current. However, for aircraft with electrically operated flap, this action is delayed until the final flap selection has been made.

Assess the approach. At the 1000-ft area, abeam the threshold, start the turn onto base leg, **never extend downwind.**

Throughout the approach, from the 1000-ft area down to approximately 500 ft agl, continuous reference is made to the $\frac{1}{3}$ aim point. No checks are carried out during this segment.

Judgement of the approach is facilitated by **repeatedly** asking, “Can I reach the $\frac{1}{3}$ aim point?”

The aim of this process is to position the aircraft at **about** 500 ft agl, so as to touch down at the $\frac{1}{3}$ aim point, **preferably** without flap.

Considerations. From a position of **about** 500 ft agl, when able to touch down at the $\frac{1}{3}$ aim point **preferably** without flap, the actual touch down point will be brought back toward the threshold, primarily through the application of flap.

This process will be practised in the glide approach lesson.

Once the final flap selection has been made, the master switch is turned OFF (touch).

During the landing, maximum braking should be used and the cabin kept intact. Consider a turn or ground-loop.

After landing the final checklist is completed.

Attend to passengers. The pilot-in-command has a responsibility for the safety of the passengers. Where possible, the aircraft is evacuated and first aid administered if required. If the aircraft is inverted, ensure passengers support themselves before releasing seatbelts.

As a flight instructor, you have a responsibility to provide a role model, therefore, a course in first aid is recommended.

Activate the ELT and stay with the aircraft. It is much easier for searchers to find the aircraft, than two or three people wandering around dazed and disoriented. In addition, the aircraft may provide shelter if required. If a decision to abandon the aircraft is made, however, take the ELT with you.

Where possible contact ATC by phone. Use of the aircraft radio is not generally recommended because turning the master on may cause a spark and subsequent fire.

Secure the aircraft. As pilot-in-command you have a responsibility for the aircraft. Tie the aircraft down, secure documents and removable equipment, such as radios, from souvenir hunters.

Do not admit liability. This is a standard insurance requirement. For example, if you've just landed in a farmer's crop, don't suggest that the aero club will replace it!

Never attempt to take off again. Not only is it illegal to move the aircraft after an accident (unless it is to prevent injury or further damage), it is poor aviation practice.

Airborne Sequence

Allow the student time to observe the indications of wind direction and strength and to choose a suitable landing site. Revise planning the forced landing pattern before closing the throttle.

Begin the exercise at a suitable height (preferably 500 ft higher than the initial introduction to forced landings) to allow discussion of the checklists during the descent. Although a demonstration and pattern **may** be given the first time the checklists are introduced, it **may** be more value to allow the student to fly the pattern and have you do, call or discuss the checks as the plan unfolds (refer CFI).

Once the student has completed a practice forced landing with checks and a return to the aerodrome initiated, a partial power failure may be simulated and the considerations discussed.

Regular revision of these two exercises (total and partial power failure) will need to be simulated throughout the student's training, as "occasional practice will have little real value"¹⁴⁸.

Once the basic approach pattern has been mastered, the commencement altitude and choice of suitable landing site should be continually varied so as to expose the student to a wide range of unique conditions.

¹⁴⁸ Campbell, 1994, p.17-2

FORCED LANDING WITHOUT POWER - THE CONSIDERATIONS

OBJECTIVES:

1. To carry out the recommended procedure in the event of a total or partial engine failure, incorporating the appropriate checklists.
2. To implement aeronautical decision making (ADM) as a result of a partial power failure.

CONSIDERATIONS:

Engine failure causes and avoidance (OHP)

Range:
Airspeed.

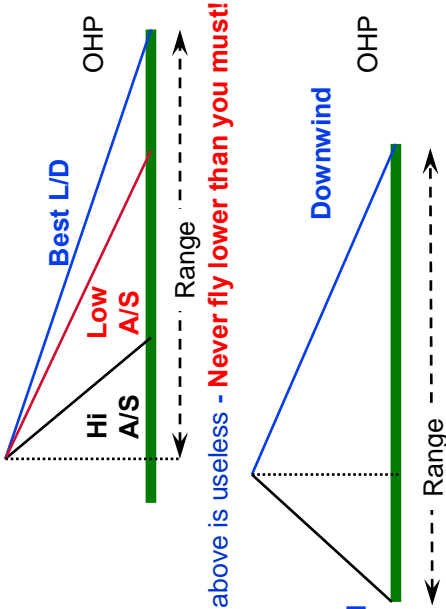

Height: Sky above is useless - **Never fly lower than you must!**

Wind:

Partial Power Considerations:

Suitability of landing sites - and the amount of power available
The terrain to be crossed - and the cause of the failure (if known)
ALTITUDE - Never fly lower than you must!

AIRCRAFT MANAGEMENT:

- Simulated** - by closing throttle
- Allow T's and P's to stabilise
- Clear engine every 1000' min.
- Touch Checks**
- Pre-flight passenger brief
- "Go-around" - ends simulation
- Not below 500' AGL**
- No Pax when practicing**
- No Right of Way**

HUMAN FACTORS:

- Disorientation**
- Prominent landmarks
- Don't fixate on checks
- Info Processing**
- Improved by **Situational awareness** & checklists
- Inhibited by **Stress**
- Procedural response
- Regular practice
- Pre-flight planning

1. Initial Actions

OHP

2. Plan App.

3. Initiate Plan

4. Trouble Checks

OHP

Assess the approach

5. Communicate

- **MAYDAY** (OHP)
- **7700**

Assess the approach

6. Passenger Brief

OHP

Assess the approach

7. Secure the A/C

OHP

Assess the approach

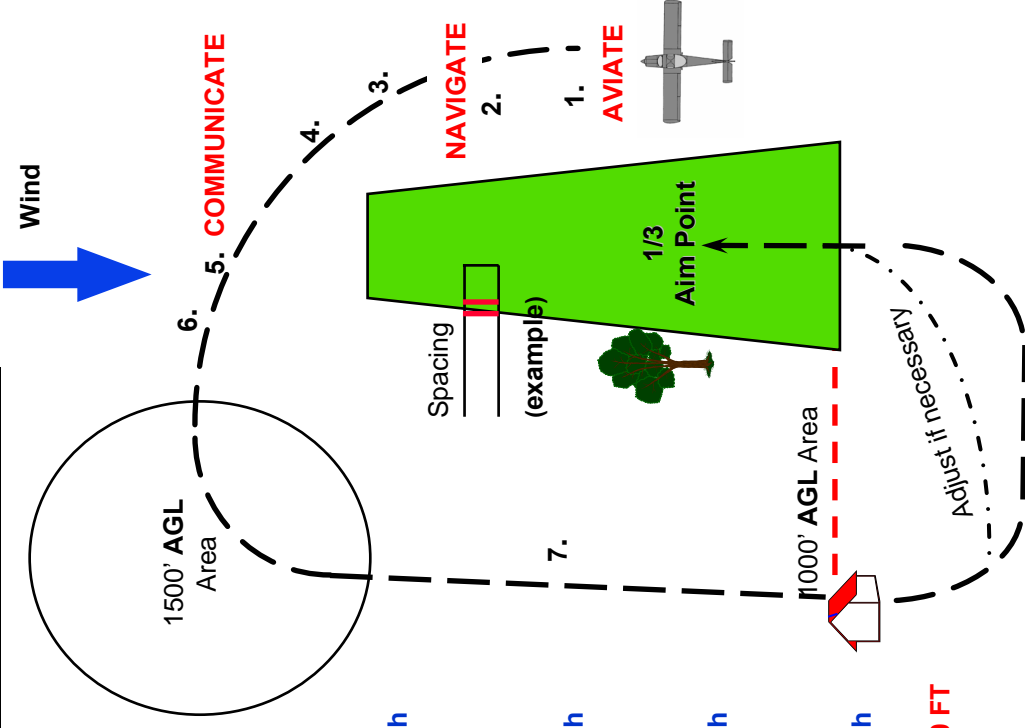

NEVER EXTEND 1000 FT AREA DOWNWIND

CONSIDERATIONS:

The touchdown point will be adjusted with flap - then master OFF
Use maximum braking - consider a ground loop - keep the cabin intact

After Landing Checks: Attend to Pax. Notify ATC, Secure A/C, Don't admit liability.

NEVER ATTEMPT TO TAKE-OFF AGAIN.

OHP

Glide Approach

Although the glide approach was taught as part of the normal circuit procedure in early aircraft without flap, in a modern aircraft it is used to simulate the last part of a forced landing without power.

The objective of the glide approach is to bring the actual touchdown point back toward the threshold, so as to utilise the maximum available length for landing. Therefore, although the glide approach is taught in the circuit, it is not part of the circuit procedure but part of the forced landing procedure.

Some organisations prefer to teach this exercise before the introduction of forced landings (refer CFI). If this is the CFI's preference the introduction and objectives should be appropriately modified.

As with EFATO and Forced Landings Without Power, this exercise is not simulated at night, as the risk outweighs any benefit.

Introduction

This exercise simulates the last part of a forced landing without power, including the landing.

From a position of **about** 500 ft agl and able to reach the $\frac{1}{3}$ aim point, **preferably** without flap, various methods are used to reduce the Lift/Drag ratio and increase the rate of descent so as to touch down as near to the threshold as practical.

Objectives

1. To revise the forced landing approach from the 1000-ft area, descending to about 500 ft agl, aiming $\frac{1}{3}$ into the runway.
2. To adjust the touchdown point to have the maximum possible runway length available for landing.

Considerations

Strong Headwind on Final

If it becomes apparent that a strong headwind on final is causing the aircraft to undershoot (aim point moves up the windscreen) it may be necessary to lower the aircraft nose, increasing the airspeed. This will increase the groundspeed, allowing the aircraft to **penetrate** into the wind. This is one of the reasons for aiming $\frac{1}{3}$ into the field and delaying flap.

Wind Shear on Final

The only method of countering windshear when no power is available is to increase airspeed. Aiming $\frac{1}{3}$ of the way into the field provides a buffer against this eventuality and is also another reason for delaying the use of flap.

Assuming that the $\frac{1}{3}$ aim point can be easily reached from **about** 500 ft agl the L/D ratio is reduced by:

Flap

Flaps are the first option for increasing the rate and angle of descent, because they increase the drag very effectively.

Airspeed

As discussed previously, gliding at any speed other than the airspeed for best L/D will decrease the range. Decreasing the airspeed to achieve this increases the risk of a stall, especially if the third option of S turns is to be used as well. Therefore, increasing the airspeed is recommended. This method, however, is not particularly effective when used on its own.

Increase the airspeed by relaxing backpressure, not by shoving the control column forward.

When combined with flap, in a modern aircraft, this method is very effective in increasing the rate of descent dramatically with only a small increase in airspeed. However, the increase in airspeed means that the aircraft will zoom or float in the round-out, so if it is used, it should be used early rather than late. After round-out the airspeed will rapidly dissipate due to the high drag produced by the flap.

S-Turns

Caution: Parallel runway operations.

An S-turn is a balanced turn. This not only increases the total distance to touch down but also decreases the L/D ratio as a result of the increased drag generated in the turn. In the modern low-drag training aeroplane this method is not particularly effective.

Sideslip

(If applicable.)

A sideslip is an unbalanced manoeuvre, where the controls are 'crossed'. For example, right aileron is applied and left rudder used to prevent the turn or to keep straight.

Due to the comparative ineffectiveness of the rudder in most modern training types, full rudder will be required to keep straight, even in a relatively shallow banked sideslip. However, **full** control deflections should be avoided. Therefore, the sink rate is best controlled with the amount of slip (rudder being used), as rudder effectiveness is the limiting factor, while maintaining the centre-line with aileron.

Once again, in the modern low-drag light aircraft, this manoeuvre is not particularly effective unless it is combined with the use of flap.

Some aircraft have a restriction against sideslipping with flap down (refer aircraft Flight Manual). This is generally because the flap blankets the tailplane in a sideslip, destroying the airflow over the tailplane. In most cases, where the tailplane normally provides a down load this results in an abrupt nose-down pitch and total elevator ineffectiveness. Although the pitch down ceases when the rudder is centralised (sideslip is stopped) this is an undesirable characteristic, especially near the ground.

If this manoeuvre is not restricted, it is vital that airspeed is increased or at least maintained. If the aircraft is permitted to stall with the controls crossed a spin is almost inevitable.

If sideslipping with flap is permitted, the resulting rate of descent is usually **very** impressive. When the student first sees the ground rushing up, there is a tendency to increase backpressure to arrest the high sink rate rather than decrease the amount of rudder being used. Therefore, if this manoeuvre is to be used it should be taught at altitude before this lesson (refer CFI).

The factors affecting rate of descent should also be applied in the above order, flap first, then increase airspeed, so that a safe margin over the stall speed is maintained during the following manoeuvres, then S turn or sideslip (if applicable).

Aircraft Management

This is only a simulation and the safety of the aircraft and crew are paramount. Therefore, power should be used at any time the safety of the aircraft is in doubt, or on the instruction “Go-around”

Plan glide approach practice with consideration for other traffic, as the exercise does not entitle you to the right of way. At controlled aerodromes request “glide approach” so that ATC can sequence following traffic.

Consistent with good aviation practice, no passengers should be carried during glide approach practice.

In using the airspeed increase method, be aware of the limiting flap speed – although this would not be a consideration in an actual forced landing.

Human Factors

Vision (ADVISE mnemonic), in relation to optic flow rates and depth perception, as a result of the high descent rates, is the prime consideration of this briefing.

Anticipate the round-out earlier as a result of the high rate of descent and to dissipate any excess airspeed as a result of using the airspeed increase method.

In addition, the effects of up-slope and down-slope on approach judgement are discussed¹⁴⁹.

Air Exercise

As the objective is to simulate the last part of a forced landing, confirm spacing and configure the aircraft late downwind. Reduce **some** power, maintain height, apply carb heat early, and trim in preparation for the glide attitude.

At the 1000-ft area abeam the threshold, the throttle is fully closed and the base turn **started**, as if the aircraft had arrived at this point on a forced landing.

The approach is judged in the normal way by reference to the $\frac{1}{3}$ aim point, down to **about** 500 ft agl. At this point the question is asked, “Can the $\frac{1}{3}$ aim point be easily reached?”

If the answer is yes. The manoeuvres to reduce the L/D ratio are applied where necessary in sequence and combined to modify the touchdown point.

If the answer is no. Delay the application of flap until the answer is a positive yes!

Airborne Sequence

It is recommended, for this introduction to the glide approach and to demonstrate how easily height can be lost (but not regained), that the full length of the runway available be used as the selected forced landing site.

For most aerodromes, choosing an aim point $\frac{1}{3}$ into the field will result in the aircraft being excessively high **in relation to the threshold**.

This is the whole point of the $\frac{1}{3}$ aim point. There is no possibility of the aircraft being flown through the first fence. When the chosen landing site is shorter, the $\frac{1}{3}$ aim point is

¹⁴⁹ refer Hawkins, 1993

still $\frac{1}{3}$ of whatever length is available, and the possibility of flying through the first fence remains constant. Only the possibility of overrunning the far end of the landing site increases.

From this excessively high position, most or all of the various methods of increasing the rate of descent can be demonstrated.

In later lessons, more realistic field lengths can be simulated by restricting the amount of runway available, for example, from the threshold to the 300 metre (1000 ft) markers. In this case the $\frac{1}{3}$ aim point will be about 100 metres in, and only those manoeuvres that are required (in sequence) will be used to modify the actual touchdown point.

This exercise should not be confused with the popular club competition of 'forced landings or spot landings. Both of these fun competitions test skill in approach judgement and therefore restrict or penalise the use of increased airspeed, S-turns and sideslip. In addition, the aim is to land on a spot, usually well into the runway, whereas the objective of this exercise is to touch down earlier than the $\frac{1}{3}$ aim point.

Forced landing practice “must be treated as an exercise in survival ... if it is to be of real value to a pilot”¹⁵⁰.

The countering of strong headwinds and windshear, by maintaining the $\frac{1}{3}$ aim point to about 500 ft agl and then increasing airspeed, are demonstrated when conditions permit.

If an undershoot develops, or more commonly the aircraft is high or fast at the threshold, and the ability to make a safe landing is in any doubt whatsoever – carry out a go-around. During the subsequent go-around, you should remind the student that maximum braking was still an option, as was executing a turn (or ground-looping a tailwheel aircraft). Do not put the aircraft in a position where these have to be used during a simulation.

Although during an actual forced landing the aircraft may be forced onto the ground so as to apply maximum braking, during the simulation a normal landing is carried out with brakes as required. Once again, remind the student that maximum braking and turning (ground-looping if applicable) are options still in reserve – and at all costs, **keep the cabin intact.**

¹⁵⁰ Campbell, 1994, p.17-1

THE GLIDE APPROACH

OBJECTIVE:

1. To revise the forced landing approach from the 1000' AGL area, descending to about 500' AGL, aiming 1/3 into the runway.
2. To adjust the touchdown point to have the maximum possible runway length available for landing.

CONSIDERATIONS:

Strong Headwind on Final:

Lower nose to increase A/S & G/S



Wind Shear on Final:

Lower nose to increase A/S

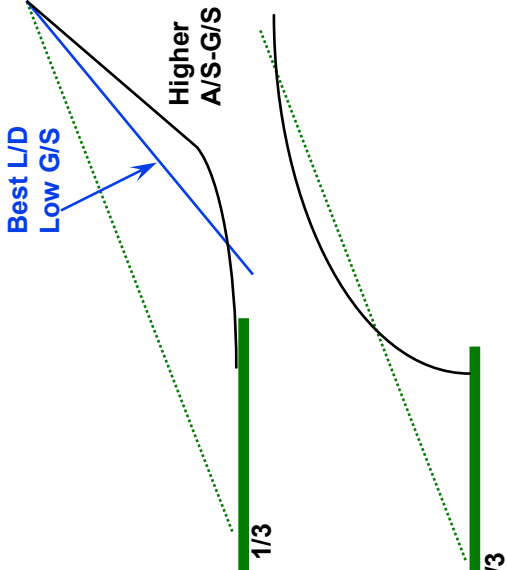

L/D Ratio is Reduced by:

1. Flap
2. Airspeed - increase ('push down')
3. S-Turn
4. Sideslip (if permitted)

AIRCRAFT MANAGEMENT:

Simulated - by closing throttle, power is available if required due under or overshoot.

No Right Of Way (R.O.W)

No Pax when practicing

Max flap speed - white arc

HUMAN FACTORS:

Vision - depth perception
- Anticipate round out

Effects of slope (OHP)

AIR EXERCISE:

1. Downwind

- Check spacing
- Nominate 1/3 aim point
- Normal downwind checks

2. Late Downwind

- Carb heat hot
- Reduce some power (2000 rpm?)
- Maintain height
- Trim

3. At 1000' (AGL) Area

- Throttle closed
- Commence turn to base
- Assess approach, aiming 1/3 in

NEVER EXTEND 1000' AREA DOWNWIND

4. At about 500' (AGL)

able to reach 1/3 area easily without flap

- Modify the touchdown point

1. Flap

2. 'Push down'

3. S-turn

4. Sideslip (if permitted)

5. After Landing or During Go-around

- Consider options - Maximum braking

- KEEP THE CABIN INTACT

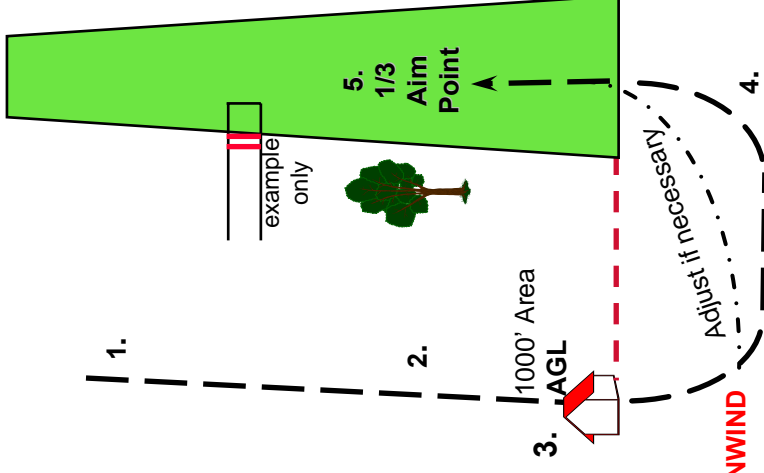

Steep Turns

For the purposes of the pre-flight briefing a steep turn is defined as a turn of more than 30 degrees angle of bank, and common practice is to teach the exercise using a 45-degree angle of bank.

The steep gliding turn has been incorporated within this briefing as one method of presenting the material. Some organisations prefer to present a separate briefing on steep gliding turns (refer CFI) and this practice is not discouraged.

Introduction

Define the steep turn. Explain why a steep turn may be desirable, for example, a higher rate of turn (revise rate) for obstacle avoidance. If you wanted to avoid something, however, you would not normally turn through 360 degrees. So, in order to improve situational awareness, to practise smooth control inputs, and to anticipate aircraft inertia, straight-and-level will be regained on the original reference point.

Objectives

1. To change direction through 360 degrees at a constant rate, using 45 degrees angle of bank, maintaining a constant altitude and balance.
2. To become familiar with the sensations of high bank angles and high rates of turn.
3. To turn at steep angles of bank while gliding.

Principles of Flight

Revise the forces in the level medium turn. There is no need to start with an explanation of the forces in straight-and-level.

Wherever possible, make sure diagrams show the aircraft flying into the board, so that the student is orientated.

When the aircraft is banked steeper, the lift vector is inclined further, and the vertical component of lift no longer supports the aircraft weight. Therefore, for the aircraft to maintain a constant altitude the vertical component of lift must be increased to equal the weight, and this is achieved by increasing the lift further. At the same time, the horizontal component of lift, commonly called centripetal force (CPF), is also increased, tightening the turn.

An example of increasing the bank even further **may** also be given. An angle of bank of 60 degrees is recommended (refer CFI) because at this point lift must be **doubled** to maintain altitude.

To this point the discussion has mostly been revision; now the acceleration forces acting on the aircraft are described.

The acceleration force opposing CPF is centrifugal force (CFF). This is the acceleration that tries to pull the aircraft out of the turn. These two 'forces', CPF and CFF, explain why water in a bucket does not fall out when the bucket is swung overhead.

The acceleration pushing the pilot into the seat is known as **load factor** (commonly referred to as G). This is equal and opposite to lift, and the wings must support it. Therefore, in level flight, where weight is 1 and lift is 1 the load factor is +1 or +1 G. At 45 degrees the

load factor is 1.41 and at 60 degrees angle of bank the load factor is doubled, +2 G, and the student will feel twice as heavy.

Some organisations mention the effects of banking at 75 degrees (this may be deferred to Max Rate Turns, refer CFI) where the load factor is increased to +3.86 (nearly +4 G). This is usually done, only for the purpose of showing that the relationship between angle of bank and G, as well as stall speed, is not linear.

The load factor (LF) is found by dividing the lift by the weight. In level flight, lift 1 divided by weight 1, equals +1. At 60 degrees angle of bank, lift 2 divided by weight 1 (unchanged), equals +2.

Although the above may interest the average student, the formula for calculating the amount of lift needed at various angles of bank is unlikely to be required (refer CFI). However, as a flight instructor you should know that the amount of lift required to maintain level flight varies with the angle of bank as $1/\cos \theta$, where weight = 1 and θ is the angle of bank.

Although your drawing will show all the 'forces' equal and opposite to each other, the aircraft is not in equilibrium!

Equilibrium is a state of nil acceleration or constant velocity, and velocity is a combination of speed and direction.

Therefore, although the student may have trouble understanding that the aircraft is accelerating toward the centre of the turn, the aircraft is clearly not maintaining a constant direction and therefore, by definition, cannot be in equilibrium.

The load factor is often referred to as **apparent weight** – because it is an acceleration (force) that the wings must support, similar to weight.

The effect of this increase in apparent weight or load factor on the stall speed is described.

The stall speed in a manoeuvre (V_{SM}) increases as the square root of the load factor. Assuming a stall speed of 50 kts in level flight, the stall speed will increase at 60 degrees by the square root of the load factor +2, which is approx 1.4. This means that, at 60 degrees angle of bank, the stall speed is increased by 40% to 70 kts.

Presentation of the formulas in a pre-flight briefing is probably not required (refer CFI). However, the numerical effects are normally presented in a table type format as in the whiteboard layout.

At the same time, because lift is increased by increasing the angle of attack, adversely affecting the L/D ratio, the drag also increases – by 100% at 45 degrees and by 300% at 60 degrees angle of bank¹⁵¹. This increase in drag, or reduction in L/D ratio, results in decreased airspeed.

This is an undesirable situation, ie, stall speed increasing and airspeed decreasing. Therefore, since power opposes drag, the power is increased to combat the increased drag with the increasing angle of bank to maintain a margin over the stall speed. This can be referred to as a **power sandwich** – see the whiteboard layout.

In the medium level turn, the lift and drag increase and the adverse affect on the L/D ratio was so slight that the decrease in airspeed was ignored. However, as the increase in drag, load factor and stall speed is not linear, the effect of increasing drag can no longer be ignored. Therefore, any turn at angles of bank greater than 30 degrees requires an increase in power. At 45 degrees angle of bank this increase will be about 100 rpm.

This explanation coincides with the patter of "through 30 degrees increase power" and is the reason why the steep turn is defined as angles of bank greater than 30 degrees.

¹⁵¹ Campbell, 1994

All of these principles also apply to the steep gliding turn. However, power is obviously not available to oppose the increasing drag and therefore, at angles of bank greater than 30 degrees, the airspeed must be increased with angle of bank increases. At 45 degrees angle of bank, the airspeed is increased by 20% of the stall speed (**about** 5 to 10 kts) to maintain a similar margin over the increased stall speed.

Adverse yaw as a result of aileron drag, and its elimination, are revised. The amount of rudder required to overcome the adverse yaw is dependent on the rate and degree of aileron deflection. The amount of rudder required is kept to a minimum by encouraging smooth control inputs. At low airspeeds the ailerons will need to be deflected further to achieve the same roll rate of higher airspeeds. This will significantly increase the induced drag and require more rudder to negate the adverse yaw. This will become apparent during gliding turns.

Aircraft Management

Any organisation-imposed minimum altitude for the conduct of level steep turns, and the minimum descent altitude for steep gliding turn practice, should be stated (refer CFI).

Above 30 degrees, power is increased with angle of bank. A 100-rpm increase at 45 degrees angle of bank is only a guide. Beware the rpm limit.

Revise SADIE checks and situational awareness in relation to countering the effect of wind to remain within the lateral boundaries of the training area.

Revise any VFR requirements considered relevant.

Human Factors

Disorientation, **V**ision and **S**tress (ADVISE mnemonic) are prime considerations of this briefing.

Disorientation is discussed in relation to situational awareness and is minimised by turning through 360 degrees, rolling out on the same reference point as that chosen before starting the turn. Because of the high rate of turn a prominent reference point should be chosen.

Revise the restrictions imposed by the airframe and the technique of looking in the opposite direction to the turn, starting at the tail and moving forward through the nose of the aircraft and into the direction of the turn, so as to minimise possible conflict with aircraft directly behind.

In addition – without causing anxiety – the effects of G on vision are discussed.

For some students the sensation of the turn may be uncomfortable at first. This will raise stress levels and decrease performance. The student should be informed that any discomfort will generally be overcome with exposure and practice, but to speak up early if uncomfortable. Ensure sick bags are on board.

Air Exercise

The air exercise discusses entering, maintaining and exiting the steep level turn at a bank angle of 45 degrees.

Entry

A reference altitude and prominent reference point are chosen and the lookout completed.

The aircraft is rolled smoothly into the turn with aileron, and balance is maintained by applying rudder in the same direction as aileron to overcome adverse yaw. At the same time, backpressure is increased on the control column to maintain altitude.

Through 30 degrees angle of bank, power is increased with the increasing angle of bank, so that at 45 degrees angle of bank power has increased by about 100 rpm.

At 45 degrees, which is recognised through attitude and confirmed through instruments, a slight check will be required to overcome inertia in roll and rudder pressure will need to be reduced to maintain balance.

The indication of 45 degrees bank angle on the artificial horizon should be explained.

Maintaining

Maintaining the turn incorporates the LAI scan. Lookout into the turn is emphasised, and the attitude for 45 degrees angle of bank and level flight is maintained.

The effect of side-by-side seating on attitude recognition should be discussed, preferably with the aid of an attitude window or OHP.

During the turn, maintain the altitude with backpressure – **provided that** the angle of bank **is** correct. Maintain lookout, negating airframe obstructions through head movement.

If altitude is being gained or lost, **first** check angle of bank. If the angle of bank is correct, adjust backpressure to maintain constant altitude.

Emphasis placed here on establishing the correct angle of bank should prevent the onset of a spiral dive.

Exit

Look into the turn for traffic and the reference point. Allow for inertia by anticipating about 20 degrees before the reference point.

Anticipating by about half the bank angle encourages a smooth roll out that is easier to coordinate.

Smoothly roll wings level with aileron, balance with rudder in the same direction to overcome adverse yaw and relax the backpressure to re-select the level attitude. Through ____ kts (normally the same airspeed used in entering straight-and-level from the climb), reduce power to cruise RPM.

If the roll out is conducted smoothly, it should be possible to co-ordinate the reduction of power with angle of bank. However, most low-powered training aircraft require the reduction of power to be delayed slightly (refer CFI).

Considerations

Out of Balance

If the aircraft is out of balance in the turn and rudder is applied to centre the ball, the further effects of rudder must be countered.

As rudder is applied, the correct angle of bank must be maintained with aileron. The resulting yaw will pitch the nose above or below the horizon, and therefore an adjustment to attitude will also be required to maintain constant altitude.

The Spiral Dive

A spiral dive is generally caused by over-banking.

If the angle of bank is permitted to increase, insufficient vertical component of lift will be produced, and the aircraft will descend. The natural tendency is to attempt to pitch the nose up by increasing backpressure. Because of the high angle of bank, this tightens the turn and increases the rate of descent.

The symptoms of a spiral dive are a high angle of bank, rapidly increasing airspeed and increasing G.

The recovery method is to close the throttle, roll wings level, ease out of the dive and regain reference altitude.

The aircraft structural limits are reduced by $\frac{1}{3}$ if manoeuvring in more than one plane. Therefore, firmly roll wings level **before** easing out of the dive.

If altitude is being lost, first check angle of bank. If the angle of bank is correct, adjust backpressure.

The decision to demonstrate an out-of-balance situation and the spiral dive should be referred to the CFI

The steep gliding turn **may** also be dealt with under the heading of considerations (refer CFI).

In the steep gliding turn, the attitude must be adjusted to maintain the nominated airspeed.

Airborne Sequence

The student should be capable of climbing to a suitable altitude with regard to the training area boundaries and VFR requirements.

Emphasise lookout before and during the turn.

Entry to, maintaining and exiting the steep level turn follows the standard airborne sequence. However, during one of the demonstrations, either left or right, ask the student to lift a foot off the floor so as to experience the effect of G.

Discourage any tendency by the student to lean out of the turn.

Once the student has completed a satisfactory steep level turn both left and right, the effects of an out-of-balance situation and/or the spiral dive may be demonstrated or practised (refer CFI).

Steep Gliding Turn

The steep gliding turn may be given either as a separate briefing before steep level turn revision (refer CFI) or demonstrated or practised here.

From straight-and-level the student enters a glide descent the same as for the forced landing. Once established in the glide a 30-degree (medium) descending turn is entered and the glide speed maintained.

With the medium gliding turn established, the angle of bank and airspeed are increased **at the same time**, to 45 degrees angle of bank and ___ kts. This is because this is the most probable sequence of events during a forced landing. If it is known beforehand that a large bank angle will be used, the airspeed could be increased in advance. However, it is more likely that the requirement for a steep turn will not be recognised until part way through the turn, for example, turning to final with a tailwind on base.

The reason for learning steep gliding turns is to guard against the tendency to pull the nose up as a result of the high descent rate, especially near the ground on the turn to final during a forced landing.

In older high-drag aircraft the steep gliding turn was recommended if the aircraft became trapped above cloud as an emergency procedure for descent through a **small break** in the cloud.

This manoeuvre is quite inappropriate for modern light aircraft.

All flight training should emphasise situational awareness to avoid this type of situation. However, if you wish to discuss such an eventuality in the modern light aircraft, apply a modern solution - as follows.

Spiralling down in the modern, low-drag light aircraft can result in a very rapid increase in airspeed and exceeding the aircraft structural G limits. Most older training aircraft were not only built to be fully aerobatic but suffered from considerable drag, which generally meant the climb speed, cruise speed and top speed were all about the same.

If the modern light aircraft is caught above cloud, the first step should be to declare an emergency.

With the current transponder coverage available in New Zealand, it is likely that ATC will quickly identify the aircraft and provide a heading to steer to a cloud-free area, or another aircraft may be sent to assist.

If descent through a **large hole** is required (emphasise avoidance), full flap, power at idle and a 45 degree maximum angle of bank should be used.

STEEP TURNS

OBJECTIVES:

1. To change direction quickly (through 360°) at a constant rate, maintaining a constant altitude and balance using 45 degrees angle of bank.
2. To become familiar with the sensations of high bank angles & rates of turn.
3. To turn at steep angles of bank whilst gliding.

PRINCIPLES OF FLIGHT: Forces acting on the A/C in a turn

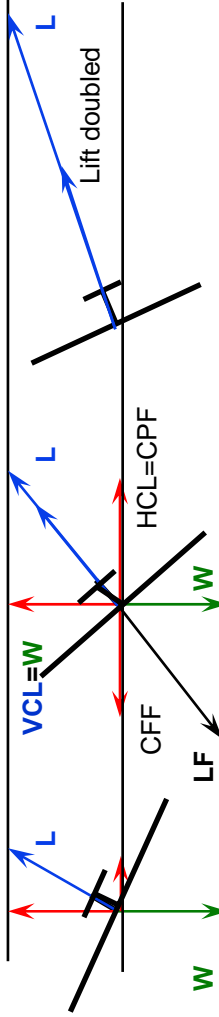

30 deg 45 deg 60 deg

Angle of Bank	Load Factor	% increase in stall speed	New stall speed
0	1		50
45	1.4	20	60
60	2	40	70
75	4	100	100

Assume Vs 50 kts.
Insert figures for your aircraft.
OHP



- Considerations when turning**
1. **Steep gliding turn** - Increase airspeed
 2. **Adverse yaw** - Balance with rudder

AIRCRAFT MANAGEMENT:

- Min Aits** (if applicable)
- Power** ↑ with bank angle (Max. RPM)
- SADIE**
- Drift** - TA boundaries
- VFR** (as applicable)

HUMAN FACTORS:

- Disorientation** - High rate of turn
- Prominent ref point
- Vision** - **LOOKout** prior and during
- Effects of G loading
- Stress** - Motion sickness
- Speak up
- Carry sickbags

AIR EXERCISE:

Steep level turns (left & right)

- Entry**
- Ref point, ref alt & **lookout**
 - Roll in - **aileron**
 - Balance - **rudder**
 - Set attitude - **elevator** (back pressure)
 - Through 30° - **↑** pwr to ___rpm
 - Check AOB at 45° - balance

coordinate

Maintain

- Lookout**
- Attitude** - maintain height with BP provided AOB correct
- Instruments** - A/H, Ball, Altimeter

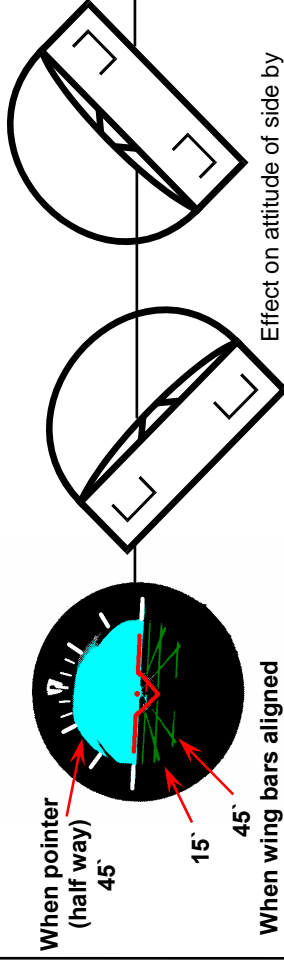

Exit

When wing bars aligned

Effect on attitude of side by side seating

Anticipate ref point (1/2 bank angle - 20 degrees approx.)

- Roll out - **aileron**
- Balance - **rudder**
- Set attitude S & L - **elevator** (ease off back pressure)
- Through ___kts **↓** pwr ___ rpm (cruise)

coordinate

Considerations:

- Out of Balance** - As rudder applied maintain correct angle of bank with aileron
- Maintain attitude with back pressure for constant height
- Spiral Dive**
- Caused by Overbanking
- **Symptoms** - High AOB, increasing A/S, high ROD & 'G'
- **Recovery** - Close throttle, level wings, ease out of dive
- Steep Gliding Turn** - **↑** airspeed through 30 degrees with **↑** AOB

Maximum Rate Turns

The maximum rate turn is not a requirement of the Private Pilot Licence syllabus under Part 61. It is included here, however, and it is examinable, because a Category C Flight Instructor may give flight instruction for the issue of a Commercial Pilot Licence. Also, like spinning and sideslipping, the CFI may elect to include max rate turns within their own training organisation's syllabus for PPL (refer CFI).

For practical purposes, the maximum rate turn and the minimum radius turn are the same thing.

To achieve the maximum rate of turn, the greatest possible force toward the centre of the turn is required. This is achieved by inclining the maximum lift vector as far as possible. Therefore, max C_L , achieved at the maximum angle of attack, is combined with the maximum angle of bank.

This briefing discusses the factors that limit the rate of turn, not only for the aircraft being flown, but also for fixed-wing aircraft in general, so that the principles may be applied to subsequent types.

Collision avoidance is often the prime reason given for learning maximum rate turns. More commonly, the exercise is practised to improve coordination and, in the case of CPL candidates, to fly the aircraft at its limits. Both of these reasons are also relevant to the lesson.

Introduction

The maximum rate turn occurs when the aircraft is changing direction at the highest possible rate, ie, maximum degrees turned through in minimum time.

The max rate turn is often taught for use in collision avoidance, however, by maintaining situational awareness this manoeuvre can usually be avoided. The important reasons for teaching max rate turns are to practice coordination and improve confidence.

For the purposes of collision avoidance, in response to an emergency situation, the turn entry requires a rapid roll in. However, the roll out is smoothly executed because the emergency is over. As an exercise, the rapid-roll in and smooth roll out provide excellent coordination practice, because two different rates of rudder and elevator application are required to match the rate of roll. Logically these turns would not be continued past 180 degrees in the case of collision avoidance. To improve coordination and orientation, however, the max rate turn is commonly practised through 360 degrees.

Objective

To change direction through 360 degrees at the maximum rate while maintaining constant altitude and balance.

Principles of Flight

The limitations of turning while using the highest possible angle of attack and at the highest possible angle of bank are discussed.

It is not necessary to draw the forces acting on the aircraft in the turn or reproduce the tables showing the effects of loading on stall speed with increasing angle of bank. The use of the OHP to quickly revise these where appropriate during the briefing is adequate (refer CFI).

Maximum Lift

Lift varies with angle of attack and airspeed. The highest useful angle of attack is just before the critical angle, about 15 degrees. At this high angle of attack, max C_L , considerable drag is produced, and if the aircraft stalls or the buffet is reached the drag will increase dramatically. Ideally, sufficient backpressure should be applied to activate the stall warning (if it is operating) on its **first** note. Alternatively, the very **edge** of the buffet will need to be used as a guide to max C_L .

There are two considerations here for discussion with your supervisor. Firstly, flying the aircraft with the stall warning activated and not carrying out the stall recovery could be considered negative transfer. On the other hand, considerable situational awareness is required to purposely operate the aircraft in this regime.

Secondly, you should be aware that experiencing any buffet will reduce the rate of turn because of its effects on drag and L/D ratio. Therefore, if the stall warning is not operating, and the lightest of buffets is used to determine max C_L , performance is degraded, and the aircraft will not be turning at its **maximum** rate.

Airspeed

The highest possible airspeed that could safely be maintained is the **maximum manoeuvring speed** – V_A . This is the airspeed, above which, if full and abrupt control deflections were made, the aircraft structural limits would be exceeded. V_A is determined by multiplying the basic stall speed by the square root of the maximum load factor. If the aircraft has a basic stall speed of 50 kts and a maximum flight load factor of 4, the V_A speed would be 100 kts ($50 \times \sqrt{4} = 100$).

If you calculate this speed for your aircraft, you may find that the answer is higher than the V_A speed stated in the aircraft Flight Manual. This is in accordance with structural safety margins incorporated by the manufacturer, and the Flight Manual speed must be considered the maximum speed.

Below the V_A speed, full and abrupt control deflections will cause the aircraft to stall before the structural limits are exceeded. Above V_A the structural limits can be exceeded, causing structural failure before the aircraft will stall.

The V_A speed is affected by the aircraft weight and reduces as weight reduces. This is because of the moments of inertia. A heavier aircraft will take longer to respond to a full control deflection than a lighter aircraft. The quick response of the lighter aircraft results in higher loading. Therefore, as the weight of the aircraft is reduced, the speed at which full and abrupt control movements can be made is also reduced (refer aircraft Flight Manual).

An exception to this sometimes occurs with aerobatic aircraft. Since V_A is related to weight and the aircraft structural limits, the V_A commonly quoted is for the normal category (all-up-weight, +3.8 G). However, if an aerobatic capable aircraft has its weight reduced, so as to position the C of G within the fully aerobatic category, the V_A speed will sometimes increase. This is because the manufacturer's G limits are markedly increased in the fully aerobatic category (+6 G and higher), negating the decrease in weight. If for example the V_S reduced to 45 kts due to the decrease in weight, but the G-limit increased to +6, the V_A speed would be 110 kts ($45 \times \sqrt{6} = 110$).

In a similar relationship, high airspeed would permit a high angle of bank to be used, but a high airspeed adversely affects the radius of the turn and therefore decreases the rate. If you have no forward speed and you jump into the air and spin yourself around, your rate of turn will be quite high. However, if you're running around a telegraph pole, although your speed may be high the rate of turn is decreased.

This relationship is given by the formulas for rate and radius of turn, where $V = \text{TAS}$ and θ is the angle of bank.

$$\text{Rate} = \frac{1091 \times \tan \theta}{V} \qquad \text{Radius (ft)} = \frac{V^2}{11.26 \tan \theta}$$

The effect on radius as a result of the velocity being **squared** outweighs the benefits of any increased lift as a result of high airspeed.

Therefore, the highest angle of bank that can be sustained at the lowest possible airspeed (just above V_s) will result in the highest possible rate of turn.

Angle of Bank

As one objective is to maintain level flight, the aircraft cannot be turned at 90 degrees angle of bank because there would be no vertical component to balance the weight, no matter how much lift was produced. Therefore, somewhere between wings level and 90 degrees there is a practical limit to the angle of bank that can be used.

Structural Limit

Refer to a graph showing the relationship of load factor to increasing angle of bank¹⁵². The structural load limit for the aircraft being considered will determine the maximum angle of bank that could be used without structural failure. Most light training aircraft have positive structural load limits of +3.8 G in the normal category and +4.4 G in the utility category. It will be seen from the graph that this limit is reached between 70 and 75 degrees angle of bank. Therefore, the average light training aircraft cannot turn at angles of bank greater than about 75 degrees without causing structural damage. These angles of bank will be greater for aerobatic aircraft because of their higher structural load limit, and lower for aircraft with lower structural limits (refer aircraft Flight Manual).

Limiting Angle of Bank

From the graph, state the limiting angle of bank for the aircraft in use.

The difference between the normal and utility category is determined by the position of the C of G (refer aircraft Flight Manual). For most light training aircraft there is no difference in the C of G range, only a restriction that the baggage compartment must be empty for the aircraft to be in the utility or semi-aerobatic category.

Those semi-aerobatic manoeuvres approved to be carried out in the Flight Manual may be carried out only in the utility category.

The steep turn generally approved as a semi-aerobatic manoeuvre in most light training aircraft Flight Manuals involves an angle of bank of about 60 degrees.

As was seen in level steep turns, an increase in angle of bank requires an increase in the angle of attack to increase the lift, which in turn increases the drag, adversely affecting the L/D ratio, resulting in a decrease in airspeed.

Power is used to oppose the increase in drag. However, since limited power is available, the airspeed **will** reduce as the angle of bank increases.

The stalling speed increases as the square root of the load factor. With a basic stall speed of 50 kts, 75 degrees angle of bank increases the stall speed to approximately 100 kts. Even if there were no drag increase this would be about the normal cruise speed.

Therefore, the maximum angle of bank will also be limited by the amount of power available to overcome the increasing drag. For most light training aircraft, this is the limiting factor at about 60 degrees angle of bank. With the amount of power available, the highest possible

¹⁵² Campbell, 1994, p.15-12

speed that can be maintained is a stall speed well below V_A (about a 40% increase over the basic stall speed). However, it is not necessarily **the** limiting factor, as the average light twin-engine aircraft or high performance single may well have sufficient power to combat the increased drag and maintain or exceed V_A . Commonly, in this case the aircraft structural limitations limit the maximum angle of bank.

The light training aircraft could maintain V_A by descending in the turn, thereby achieving **the** maximum rate of turn. This manoeuvre is not practised or even demonstrated (refer CFI) as the risk of operating the aircraft at its structural limit cannot be justified in general aviation flight training.

Limitations of the Pilot

The only other limitation on achieving the maximum rate of turn is that of the pilot.

With an increasing positive load factor or G, the heart has difficulty pumping blood to the brain. Because the eyes are most sensitive to blood flow, the effects on vision of increasing G are noted.

Spots before the eyes form at about +3 G, with grey-out occurring at about +4 to +5 G, and blackout about +6 G.

These effects vary between individuals and are affected by physical fitness, regular exposure and anti-G manoeuvres or devices, for example, straining, or the use of a G-suit.

During the max rate turn, in most light training aircraft, the increased G would not be expected to exceed +2 G.

Aircraft Management

The aircraft V_A speeds at all-up-weight and empty (if given in the Flight Manual) are most relevant to this exercise. A stall, or the use of abrupt control movements to initiate the entry, must be avoided above this speed.

For light training aircraft, the increase in drag will require that maximum power is used – caution rpm limit.

The aircraft C of G limitations for the normal and utility categories may be revised.

Any organisation-imposed minimum altitude for the conduct of max rate turns should be stated (refer CFI).

Human Factors

Disorientation and **V**ision (ADVISE mnemonic) are the prime considerations of this exercise. However, should this manoeuvre be required as a result of some obstruction, stress will also be relevant.

Disorientation is minimised by choosing a very prominent reference point. In addition, regular practice at conducting the turn through 360 and 180 degrees (in later lessons, refer CFI) will also improve orientation.

The effects of G on vision have been discussed above (or deferred to this section, refer CFI). It should be emphasised that these effects are **additional** to the normal restrictions on lookout and combined with a high rate of turn.

Stress is minimised through regular practice. But stress reduction through situational awareness should be emphasised. Similar to stalling, the aircraft should never be in a position where this manoeuvre is required.

Air Exercise

The air exercise discusses entering, maintaining and exiting the level max rate turn.

Entry

A reference altitude and very prominent reference point are chosen and the lookout completed.

A check is made to establish where the aircraft speed is, in relation to V_A for the aircraft weight at the time. For most light training aircraft, entering the max rate turn from level flight, the airspeed will be about 10 to 20 kts below V_A .

Assuming the airspeed is below V_A , the aircraft is rolled rapidly, **but smoothly**, into the turn with aileron, and balance maintained by applying rudder in the same direction as aileron. As large deflections of aileron are used, more rudder than usual will be required to overcome adverse yaw.

At the same time, backpressure is increased on the control column, pulling smoothly to the stall warning (or light buffet) to maximise lift. Power is increased with the increasing angle of bank, so that full power is applied at about 60 degrees angle of bank.

When the stall warning is activated, maintain backpressure. At about 60 degrees, which is recognised through attitude and confirmed through instruments, a slight check will be required to overcome inertia in roll and rudder pressure will need to be reduced to maintain balance.

In the entry from straight-and-level, excess airspeed may permit a higher angle of bank to be selected initially, especially if the roll is very rapid. However, as the airspeed reduces, the angle of bank will need to be reduced to about 60 degrees to maintain altitude. Therefore, for the purposes of coordination, it may be beneficial to roll rapidly but smoothly, so that the airspeed reduction coincides with the bank angle of about 60 degrees and with the application of full power (refer CFI).

If the very rapid roll-in is preferred (for a true avoidance turn rather than a coordination exercise), the initial angle of bank must not exceed the angle of bank at which the structural limits are reached.

Maintaining the Turn

Maintaining the turn incorporates the LAI scan. Emphasise lookout, and maintain the attitude for 60 degrees angle of bank and level flight.

The effect of side-by-side seating on attitude recognition should be discussed, preferably with the aid of an attitude window or OHP.

During the turn, maintain the maximum amount of lift for the airspeed by maintaining the first note of the stall warning with backpressure.

As the lift cannot be increased any further, the altitude is maintained with angle of bank. Therefore, with the stall warning activated, if altitude is being gained or lost, alter the angle of bank.

Increase bank angle only to the maximum coinciding with the aircraft structural limit. An alteration of ± 5 degrees angle of bank should be sufficient to maintain altitude.

Exit

Look into the turn for traffic and the reference point, and allow for inertia by anticipating about 30 degrees before, and roll out smoothly.

Theoretically the emergency is over; anticipating by half the bank angle will require a reduced rate of rudder application compared to the entry. This provides practice in coordination.

Smoothly roll wings level with aileron, balance with rudder in the same direction to overcome adverse yaw, and relax the backpressure to re-select the level attitude. Most low-powered training aircraft require the reduction of power to be delayed on exiting the max rate turn. Therefore, through ___ kts (normally the same airspeed used in entering straight-and-level from the climb) reduce power to cruise rpm.

Considerations

Entry Speed Above V_A

If the airspeed is above V_A for the weight, the entry must employ a smooth roll in. Generally, the application of power is delayed until the aircraft decelerates to V_A . Then, power is applied as required to counter the increasing drag in an effort to maintain V_A (for the weight).

Entry Speed Well Below V_A or Normal Cruise

This would be any airspeed around the stall speed for 60 degrees angle of bank (V_s plus about 40%, eg, 50 kts plus 40% = 70 kts).

In this case, power should lead the roll-in or be applied rapidly but smoothly as soon as the roll-in is started.

Airborne Sequence

The airborne sequence is standard. During one demonstration, the student's attention should be drawn to the rate of turn by looking at the rate at which the nose progresses around the horizon. If the aircraft is brought to the buffet or stall, the rate of turn will noticeably decrease. Inclusion of this demonstration is at the CFI's discretion.

MAXIMUM RATE TURNS

OBJECTIVE:

To change direction through 360° at the maximum rate while maintaining constant altitude and in balance.

CONSIDERATIONS:

Definition: $\frac{\text{Maximum degrees turned through}}{\text{Time}}$

Reasons for a max rate turn

- Obstacle avoidance - Aircraft
- Terrain
- Weather

Co-ordination exercise

- 360 degrees
- 180 degrees

Requirements

- Maximum Lift - Max C_L - Critical angle - Stall warning
- Max A/S - V_a (for weight)

But Rate = $\frac{1091 \times \tan \theta}{V}$ req highest AoB at lowest sustainable airspeed

Limitations Maximum AoB > 0 but < 90 degrees

1) Structural limits: +3.8g to +4.4g at 70 to 75 deg AoB (approx)
At 60 deg AoB approx +2g (OHP)

2) Aerodynamic Limits: As AoB ↑ Drag ↑ A/S ↑

For this A/C at 60 deg AoB $V_s = \text{---}$ knots ($V_s + 40\%$)

3) Power Limits: Power available to oppose Drag: As AoB ↑ A/S ↓

Power Sandwich Limited to 60 Deg AoB (approx)

V_s ↑

4) Pilot Limits: Ability to Sustain "G" 3 - 4 g Grey-out 5 - 6 g Black-out

AIRCRAFT MANAGEMENT:

V_a at AUW -

Empty -

Full Power - RPM limit

Normal & Utility Category

Min Alt

HUMAN FACTORS:

Disorientation - prominent ref point

- practice 360° (180°)

Vision - effects of 'G'

- high rate of turn

- practice

- situational awareness

AIR EXERCISE:

Maximum Rate Level Turns Left and Right

Entry

- Very prominent ref point, ref altitude
- Lookout
- Above kts ($V_s + 40\%$) and below V_a
- Positive entry (aileron & rudder)
- Smoothly increase power to full power
- Increase back pressure to stall warning
- Check AoB approx 60 degrees

Maintain

- Lookout
- Attitude - maintain height with AoB ($\pm 5^\circ$)
- maintain stall warning with BP
- Instruments A/H, Ball, Altimeter

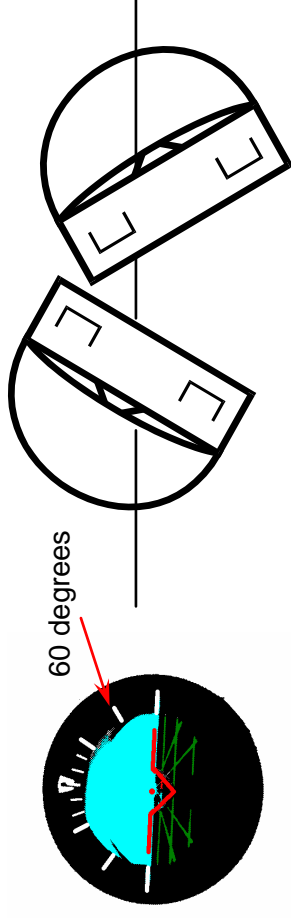

Exit

- Anticipate reference point by 30 degrees
- Smooth exit (aileron & rudder)
- Relax BP
- Above knots ↓ power to rpm (cruise)
- Confirm wings level and in balance

Considerations

Airspeed above V_a - Roll in smoothly delay power till V_a

Airspeed at or about $V_s + 40\%$ - Lead with power

Wing-Drop Stalling

This briefing discusses the reasons why one wing may stall before the other, resulting in the stall commonly known as a **wing-drop stall**, as well as the consequences and correct recovery technique.

Stalling in the turn may produce the same consequences and requires the same recovery technique. Only the entry and the last item in the recovery are different if the turn is to be maintained rather than level flight regained. Therefore, stalling in the turn **may** be incorporated within this briefing. However, at the PPL level, the CFI may prefer a separate briefing for stalling in the turn (refer CFI).

Introduction

By wing-drop stall we mean one wing stalls before the other. The wing that reaches the critical angle first (at about 15 degrees) will stall first, losing lift and causing a roll at the stall. This often happens because the aircraft is out of balance at the stall, or aileron is being used.

Once the wing stalls, aileron is ineffective in stopping the roll, and it may worsen the situation. If the wing-drop is not promptly recovered, a spin may develop. The purpose of this exercise is to overlearn another method of stopping the roll so as to negate the natural tendency to pick the wing up with aileron.

In addition, the causes of the stall will be revised and recovery at onset emphasised to improve situational awareness.

Objectives

1. To revise stalling with power and flap, recovery at onset.
2. To carry out the wing-drop stall from straight-and-level flight and the turn, recovering with minimum altitude loss.
3. To improve situational awareness by recovering at the stall onset.

Principles of Flight

Revise the cause of the stall – exceeding the critical angle of attack, regardless of the observed airspeed.

The reasons why one wing may stall before the other are explained.

The most common cause of one wing exceeding the critical angle before the other is a result of using aileron at or near the stall. The down-going aileron increases the angle of attack on that wing, while the up-going aileron decreases the angle of attack on the other.

There are many reasons why aileron may be being used at the stall:

- **Turning.** During the turn, angle of bank is maintained with aileron.
- **Out of Balance.** If the aircraft is permitted to yaw at or near the stall there will be a tendency for the aircraft to roll (further effect of rudder), which will increase the angle of attack on the down-going wing. In addition, if an attempt is made to maintain wings level with aileron, the down-going aileron will increase the angle of attack on the down-going

wing even further. This usually results in the down-going wing reaching the critical angle first.

- **Ice or Damage.** If ice forms on the wings, or one wing is damaged, by bird strike or hangar rash, the smooth airflow over the wing will be disturbed, reducing lift. If this is compensated for with aileron, one wing will reach the critical angle first.
- **Weight Imbalance.** If all the passengers or fuel are on one side of the aircraft, some aileron will be required to maintain wings level.
- **Turbulence.** When operating near the critical angle, a gust or turbulence may result in aileron being used to maintain wings level, or the modified airflow as a result of the gust may cause one wing to exceed the critical angle.
- **Rigging.** If the wings were fitted to the aircraft at slightly different angles of incidence, approaching the stall, one wing would reach the critical angle before the other.
- **Power.** Slipstream modifies the angle of attack on each wing because of its rotational nature. In clockwise rotating engines (as viewed by the pilot), the angle of attack is decreased on the starboard wing and increased on the port.
- **Flaps.** It is possible for flap to extend at slightly different angles. In addition, when flap is extended the aircraft is less laterally stable, as the centres of pressure on each wing move in toward the wing root. This increases the tendency for the aircraft to be easily disturbed in roll, which may cause one wing to exceed the critical angle. However, there is also a greater need to use aileron to maintain wings level in this configuration.

The consequences of one wing exceeding the critical angle before the other are discussed.

The wing that stalls first has a reduction in lift, causing roll. The roll increases the angle of attack on the down-going wing and may delay the stall of the up-going wing. Increasing the angle of attack past the critical angle will result in a decrease in lift but a substantial increase in drag (use OHP, C_L and C_D against angle of attack graph).

The increase in drag yaws the aircraft toward the down-going wing, which may further delay the stall of the up-going wing as a result of increased airspeed. This process, where yaw causes roll, which causes yaw, is known as **autorotation**.

By using aileron to stop the roll (a natural tendency), the angle of attack increases on the down-going wing. The lift continues to decrease with an increase in angle of attack (past the critical angle), while the drag continues to increase rapidly with any small increase in angle of attack. Use overlay on OHP to show effect of aileron on C_L and C_D .

The use of aileron adversely affects the roll and favours autorotation. This is the reason for maintaining ailerons neutral in the initial stall recovery.

The correct method of stopping autorotation is to break the yaw-roll-yaw cycle. Since aileron cannot be used effectively to stop the roll, rudder is used to prevent further yaw, and that immediately stops the roll.

Aircraft Management

Revise the requirement to carry out all stalling practice in a safe environment through HASELL/HELL checks.

As the objective is to carry out a wing-drop stall, preferably without grossly mishandling the aircraft, a configuration most likely to induce a wing-drop is used. Some power, commonly

1700 rpm, and some flap, commonly full flap, is used. Some aircraft types, eg, PA38, will perform good wing-drop stalls in the basic configuration (power idle, flap up). Refer CFI.

The combination of these two factors will often lead to a wing-drop occurring at the stall.

The use of carb heat may require revision.

Emphasise symptom recognition for avoidance.

Human Factors

The effects (ADVISE mnemonic) of **D**isorientation and **S**tress are the prime considerations in this briefing.

Situational awareness is the prime consideration of all stalling exercises. The student should strive to improve situational awareness by integrating the attitude and airspeed with the aircraft configuration, phase of flight and symptoms of the approaching stall.

The reduction of stress through practice (desensitising) is an important goal of this exercise, as well as overlearning. In this case overlearning is used to improve information processing to recognise the situation and consciously ignore the roll while responding with the correct recovery technique.

Air Exercise

In order to revise stalling generally, and to desensitise, the student should first carry out some stalls in various configurations, recovering at the onset.

When satisfied that the student is ready to progress, you should begin the exercise with the demonstration and patter of a wing-drop stall (see “Airborne Sequence”)

Entry

HASELL checks are completed, and a prominent outside reference point (backed by the DI) on which to keep straight is nominated.

From level flight, carb heat is selected hot and the power smoothly reduced to _____ rpm. As the nose will want to yaw and pitch down, keep straight with rudder and hold the altitude with increasing backpressure.

Below _____ kts (white arc) select flap gradually if applicable to aircraft type. During the application of flap, check forward to prevent any gain in altitude due to the increase in lift, before reapplying backpressure to maintain altitude.

Through _____ kts, or when the aural stall warning is heard, select carb heat cold, as full power will shortly be reapplied.

At the stall, altitude is lost, the nose pitches down, and one wing drops.

Since all stall training emphasises avoidance and recovery at the onset through situational awareness, **do not** hold the aircraft in a prolonged stall in an effort to induce a wing-drop. If the aircraft does not drop a wing at the stall, carry out the full recovery.

If the aircraft is reluctant to drop a wing at the stall, alter the power and flap combination (refer CFI). As a last resort, relax rudder pressure in the final stages of the entry, to simulate the pilot’s failure to maintain directional control. Do not induce the wing-drop by applying rudder. Alternatively, a gentle turn may be required (5 degrees angle of bank). There is nothing underhand about these techniques, as permitting the aircraft to yaw or stall in the turn are possible wing-drop causes.

In addition, avoid an accelerated stall (by not zooming in the entry, but rather by maintaining altitude) which may produce a rapid roll. Since all emphasis will be on recovery at onset, there is little to be gained in demonstrating a violent wing-drop that may inhibit learning. If a pronounced wing-drop occurs, the application of full power may need to be delayed.

Recovery

The recovery may be discussed in three parts, but the ultimate objective is to coordinate all three actions.

To unstall, decrease the backpressure or check forward, ailerons neutral. The student should be reminded that check forward is a positive or brisk control movement but not a push. The reason for ailerons neutral is revised with reference to the principles or considerations.

At the same time, use sufficient opposite rudder to prevent **further** yaw.

Excessive rudder should not be applied (to level the wings through the secondary effect of rudder) as this may cause a stall and flick manoeuvre in the opposite direction to the initial roll (wing-drop).

To minimise the altitude loss, full power is smoothly but positively applied. At the same time, level the wings with aileron (as the aircraft is now unstalled), centralise the rudder, and raise the nose smoothly to the horizon to arrest the sink and minimise the altitude loss.

Hold the nose at the level attitude, and reduce the flap setting (as appropriate to aircraft type) immediately

Safe height, safe airspeed and a positive rate of climb – raise remaining flap (counter the pitch change). The aircraft will continue to accelerate, and at the nominated climb speed select the climb attitude.

Straight-and-level flight should be regained at the starting altitude and the reference point or heading regained.

Airborne Sequence

The student should be capable of positioning the aircraft within the training area at a suitable altitude, completing the necessary checks, and possibly carrying out the advanced stall and recovery at onset. Instructor assistance is given only as required.

The airborne sequence is standard, however:

For the purposes of demonstration and patter, the recovery **may** be broken down into three separate phases (refer CFI). Alternatively the three phases may be condensed into two or even one phase, depending on your assessment of the student's ability.

If you elect to pause after checking centrally forward, the aircraft will be unstalled nose down, one wing down, and yawing.

If you elect to pause after the application of rudder to prevent further yaw, the aircraft will be unstalled, nose down and wing down.

It is recommended that all stalling exercises finish with a recovery at onset to improve situational awareness and reduce stress.

WING-DROP STALLING

OBJECTIVES:

1. To revise stalling with power & flap, recovery at onset.
2. To carry out the wing-drop stall from straight-and-level flight or in the turn, recovering with minimum height loss.
3. To improve situational awareness by recovering at the stall onset.

PRINCIPLES OF FLIGHT:

The A/C stalls at the critical angle, regardless of airspeed.

Factors Which May Cause a Wing Drop

- Turning out of balance
- Weight imbalance
- Rigging
- Flap
- Ice/damage
- Turbulence
- Slipstream

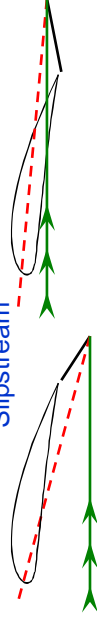

If we use aileron to raise the down going wing we increase A/A and aggravate the wing drop. **KEEP AILERONS NEUTRAL**

The effect on both up and down going wings at the stall

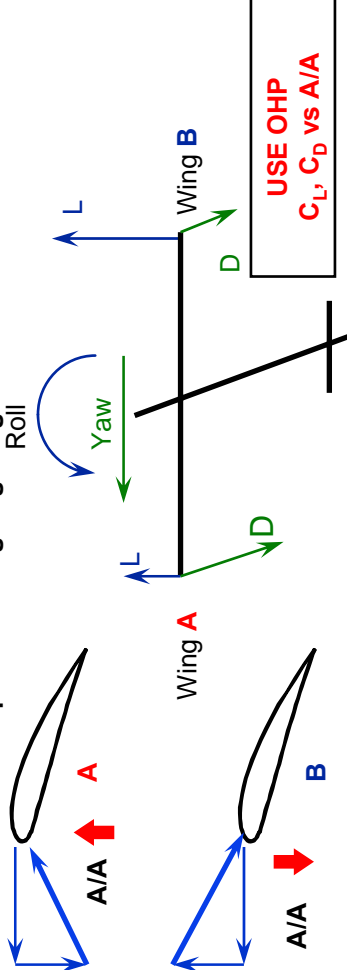

AIRCRAFT MANAGEMENT:

HASELL - HELL Checks

Power: _____ rpm
Flap: _____ full

Carb Heat: Hot below _____ rpm
Cold prior to the stall

Symptom Recognition

HUMAN FACTORS:

Situational Awareness

- Aircraft attitude & airspeed
- A/C configuration & flight phase
- Symptoms

Stress

- Regular practice
- Desensitise
- Overlearn for info processing

AIR EXERCISE:

1. Revise power and flap stall, recovery at onset

2. Wing drop stall - _____ rpm - _____ Flap

Entry

- Haseil/ Hell Checks - Ref pt
- Carb ht Hot
- Power **↓** to _____ rpm Keep straight
- Below _____ knots, Lower _____ flap
- Maintain height and direction
- At _____ knots or stall warning Carb Ht Cold
- (Pilot fails to maintain direction - if necessary)

Symptoms

- Low and decreasing airspeed
- Controls light and less effective
- Stall Warning
- Buffet

At the stall the A/C sinks, the nose pitches down and one wing drops.

Recovery

To unstall

- Check centrally forward
- Preventing further yaw with rudder

To minimise height loss

- Full Power
- Level the wings & centralise rudder
- Smoothly raise the nose to horizon
- Reduce from full flap setting
- Safe height, speed & +ve ROC
- Raise remaining flap gradually
- At _____ kts
- Climb to ref alt, regain ref point

Coordinate

3. Recovery at onset

Note: No stall

No height loss

No wing drop

MAINTAIN SITUATIONAL AWARENESS

Compass Turns

The **emergency standby** (E2) magnetic compass is the **primary** navigation aid for most light aircraft. Although GPS has the potential to become the primary navigation aid, even for light training aircraft, the magnetic compass will probably always be retained as an emergency standby system.

In using the magnetic compass for navigation purposes, there are more considerations than just the turning errors and therefore, the title Compass Use for this briefing may be more appropriate (refer CFI).

In the context of a pre-flight briefing, the cause of compass errors is not as important as how to compensate for those errors in flight. A basic understanding of the causes of compass errors is all that is required. Any explanation should be relevant to the modern aircraft magnetic compass.

Campbell¹⁵³ explains these errors in relation to the inherent tendency of the compass to align with the earth's magnetic field, and this text follows that method of explanation. Be aware, however, that Campbell refers to acceleration and turning errors in the Northern Hemisphere, and that these are reversed in the Southern Hemisphere.

Introduction

The magnetic compass is the only instrument in most light aircraft that indicates the aircraft heading. The directional indicator (DI) or directional gyro (DG) is simply gyro-stabilised and can be set to any heading. To be of any value it must be manually aligned with the magnetic compass on a regular basis.

The magnetic compass displays several errors in its use, most of which the DI eliminates. If for any reason the DI becomes unusable, for example, through a suction pump failure, the pilot may need to be able to turn onto and maintain a compass heading.

Objective

To turn accurately onto and maintain compass headings, compensating for known errors in the aircraft magnetic compass.

Considerations

The various errors of the aircraft magnetic compass are discussed in their simplest form.

Variation

The earth has a geographical (True) North Pole and a geographical (True) South Pole.

Around the earth exists a magnetic field produced by the equivalent of a bar magnet within the earth (use OHP). This results in a Magnetic North Pole and a Magnetic South Pole.

¹⁵³ 1994

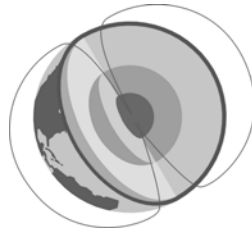

Introducing a simple bar magnet into this field will result in the magnet attempting to align itself with this field or lines of flux. The difference between the True and Magnetic Poles is called **variation**. Compensating for this difference will be explained in future navigation exercises.

Deviation

When the bar magnet or magnetic compass is acted upon by a magnetic field other than the earth's, the magnet deviates. Most metal objects or electrical fields, such as in an aircraft, produce a magnetic field that will cause the compass to read incorrectly. This effect is known as **deviation**. It is compensated for by the compass swing procedure, which both minimises the errors and records the residual errors.

Dip

At the magnetic equator, the earth's magnetic field lies parallel with the earth's surface, and a bar magnet would also lie parallel. As the poles are approached, the lines of flux **dip** down toward the earth's surface and so does a bar magnet (OHP use recommended).

Dip makes the use of a magnetic compass impossible in high latitudes, ie, near the poles. In New Zealand, the lines of flux enter the earth's surface at approximately 60 degrees. Suspending the magnet and compass card from a pivot point almost eliminates dip. Some tendency for the magnet to dip toward the nearest pole remains, however, and this is known as **residual dip**, and in New Zealand it is approximately three degrees.

The pivot arrangement is fairly unstable, however, so the compass card and magnets are immersed in a fluid that damps out oscillations – and also provides lubrication.

Acceleration Errors

When the magnet is not aligned with the earth's magnetic field or lines of flux, the part of the magnet behind the pivot point will be subject to a different acceleration or deceleration from the aircraft.

For example, when the aircraft **accelerates**, the magnet lags or swings backwards, because of the effect of inertia. When this happens on a heading of north or south, no effect other than dip is observed because the magnet and the lines of flux are aligned. However, when this happens on a heading of east or west, the magnet is at an angle to the lines of flux and the magnet rotates to realign itself with the earth's magnetic field. In the Southern Hemisphere the pilot will see an **apparent** turn toward the south.

In a similar manner the effects of decelerating can be shown to produce an apparent turn toward the north in the Southern Hemisphere.

In summary, an apparent turn toward the **South** when **A**ccelerating will be indicated and an apparent turn toward the **North** will be indicated when **D**ecelerating.

The mnemonic **SAND** is used to remember the effects of accelerating or decelerating. What is more important, however, is what the pilot should do about them. Before instrument flight

is taught the student needs to be aware that acceleration and deceleration errors occur on **all** headings other than north and south but are a maximum on east and west. Also the importance of flying on a distant visual reference point, rather than by continuous reference to the magnetic compass, is emphasised so that the apparent turn may be ignored.

Although power changes in aircraft with sufficient power may produce an acceleration or deceleration error, these errors are most noticeable in light aircraft during attitude changes.

Turning Errors

These are explained in a similar manner to acceleration errors. On a heading of east or west, if the aircraft is banked, the bar magnet remains aligned with the flux line. On any other heading, most noticeably on north or south, there will be an angular difference between the bar magnet and the flux line. This causes the compass to rotate to realign the magnet with the flux line.

A turn toward northerly headings will result in the south-seeking end of the bar magnet accelerating the turn as it aligns with the flux line. Hence, in the Southern Hemisphere, the compass is described as “lively on **N**orth”, ie, the pilot reads 000 against the lubber line before the aircraft heading actually reaches 000.

A similar description is given of turns onto southerly headings, when the compass is described as “**S**luggish on **S**outh”, ie, the aircraft heading is reached before the compass indicates it.

To compensate for these erroneous readings during the turn, the pilot must continue the turn past the indicated heading when turning onto northerly headings, and stop the turn short of the desired compass heading when turning onto southerly headings. The mnemonic **ONUS** is used to remember this; **O**verturn the required heading when turning onto **N**ortherly headings and **U**nderturn the required heading when turning onto **S**outherly headings.

The difference between the desired compass heading and what is indicated in the turn depends on latitude (there is no error at the equator) and angle of bank. In addition, during the turn there is an acceleration toward the centre of the turn (CPF). To minimise these effects a very gentle turn is required. Therefore, the compass turn is carried out at Rate 1; this is a turn of 360 degrees in two minutes.

In a Rate 1 turn the error between the desired heading and the indicated heading on 000 and 180 is approximately 30 degrees in New Zealand. For this correction to work the turn **must** be Rate 1, balanced, level and without pitch changes.

The angle of bank required to achieve a Rate 1 turn varies with the airspeed¹⁵⁴. As a guide, it can be calculated as 10% of the TAS, plus 5 kts up to 100 kts, or plus 7 kts above 100 kts. Therefore, with a TAS of 100 kts, the angle of bank required is approximately 15 degrees.

More conveniently, the aircraft turn coordinator should indicate a balanced Rate 1 turn at the aircraft normal cruise airspeed (it will not indicate the aircraft angle of bank).

Aircraft Management

The aircraft compass system should be checked for serviceability before flight.

If the fluid in the compass has bubbles or leaks out, the compass will become less stable. Check for cracks or fluid leaks as well as fluid discoloration.

¹⁵⁴ Kermodé, 1996

Ensure that the deviation card is valid by checking that the expiry date printed on the card has not passed. Although the corrections given for various headings are generally considered insignificant for practical flight use, the deviation card is the pilot's only indication that the compass swing has been done, and that any errors found were not excessive.

The introduction of any metal object or electrical field, such as headphones, GPS or calculators, into the cockpit will affect the accuracy of the aircraft magnetic compass. Keep these items as far away from the compass as possible.

During taxiing the compass is checked for correct sense – turning right, numbers increasing, turning left, numbers decreasing. On lining up, the compass heading is compared with the runway heading and can be expected to be within approximately 10 degrees.

The aircraft turn coordinator should also be checked for serviceability. Most turn coordinators are electrically driven and display a red warning flag when power is not being supplied. During turns while taxiing, the turn coordinator should display a rate of turn in the correct sense.

As vacuum pump failure is the most likely cause of DI failure, the suction gauge should be checked during engine runup (4.5 to 5.2 inches of Hg).

Human Factors

The prime consideration of this briefing is to maintain situational awareness in order to minimise **D**isorientation and assist with **I**nformation processing (ADVISE mnemonic). In addition, the lookout may suffer because the student is distracted by the need to make calculations and by the effects of stress.

To minimise disorientation, a three-dimensional picture, including the cardinal points of the compass, should be developed and retained in the pilot's memory. .

Information processing is affected by the limitations of short-term or working memory. Therefore, in-flight mental calculations should be kept to a minimum. In addition, the pilot should not have access to unreliable information that could be used¹⁵⁵. It is recommended that unreliable information, ie, instruments that have failed, are removed from the pilot's scan. Covering the instrument is usually the best way to achieve this.

The stress associated with completing a compass turn is reduced with practice and by following a procedure or number of steps.

Emphasise that lookout is the most important part of any turn and must be maintained, before, during and after the turn.

Air Exercise

The air exercise starts with a demonstration of the apparent turn caused by acceleration errors (SAND). To compensate for these errors, maintain the reference point or ignore compass indications during phases of acceleration and deceleration (pitch changes).

A demonstration of turning errors will be given and the methods of compensating for these discussed (ONUS).

¹⁵⁵ Wickens & Flach, 1988

The compass rose, in plan view, is divided into two halves and the cardinal headings labelled. Turning errors are zero on east and west, and a maximum of 30 degrees on north and south; label these.

Intermediate headings and their associated error may now be labelled (see whiteboard layout). In addition, the top half of the rose is labelled **ON** and the bottom half **US**.

This information will need to be memorised by the student and should be included in the lesson handout.

The procedure for turning onto a specific compass heading is broken down into several steps:

Making the Turn

Which Way to Turn?

The turn is always made in the shortest direction; for example, a turn from east to north requires a turn to the left.

Given the presentation of the compass rose, this is quite a simple deduction. However, the aircraft magnetic compass does not present the information in this format. Therefore, some method of deciding which is the shortest arc to turn through must be provided to the student.

It is assumed that the DI has failed or is unreliable. Therefore, in accordance with the recommendations given under human factors, the DI is removed from the pilot's scan. As the simple plan view of the compass rose is easy to interpret and is what the student has memorised, some other instrument, preferably orientated with north always at the top, is substituted for the DI.

There are several methods available.

Firstly – and best – the back of the cover used to hide the DI could have a drawing printed on it that shows the error or correction associated with each cardinal and intermediate heading.

Secondly, if the aircraft is fitted with an ADF or VOR, the remote indicators associated with these (ADF card or CDI) may be used as a reference.

The first step in visualising which way to turn, so as to turn through the shortest arc, is to read the compass. This heading is plotted on the DI cover drawing, ADF, or VOR.

Then the desired heading is plotted in the same manner and the shortest arc chosen; for example,

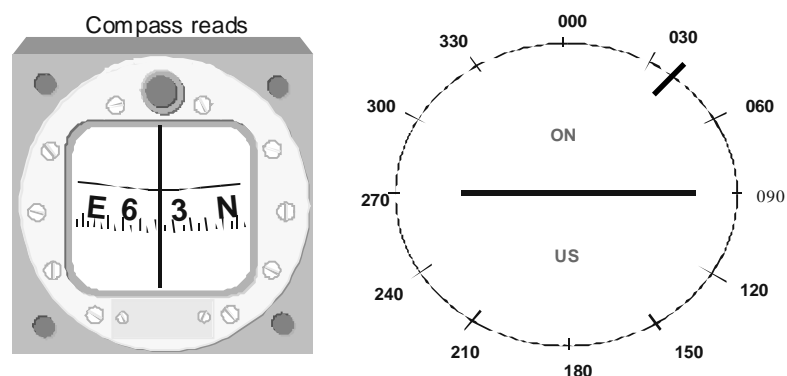

Turn Left

This method avoids mathematical calculations. However, when the heading required is near the reciprocal of the current heading, it may result in a turn the wrong way. In practical terms, if the desired heading is at or close to the reciprocal, a turn in the wrong direction will have little impact.

Will an Overturn or Underturn be Required (ONUS)?

Without access to the error/correction drawing, this would require the student to know, for example, that 120 is a southerly heading.

In practice this can be deduced from the various methods above.

What Correction Will Need to be Applied?

Unless a drawing on the back of the DI cover is supplied, the student needs to memorise the correction factors.

What Will the Compass Read When the Rollout is Started?

There are two methods to determine this.

Firstly, the heading on which to start the roll-out can be calculated mentally by adding or subtracting the correction factor. However, this not only requires an appreciation of whether to overturn or overturn but also depends on which way the turn is being made. For example, a turn onto north from 090 requires an overturn of 30 degrees to a roll-out heading of 330 (subtract 30), while a turn onto north from 270 will result in a required roll-out heading of 030 (add 30).

The other method relies on the emphasis placed on the meaning of overturn and underturn. Overturn means **go past** the desired heading, while underturn means **stop short** of it. In the case of overturn, therefore, the turn is continued until the desired heading is seen under the lubber line and the turn continued for the appropriate correction. In the case of underturn, when the desired heading is seen approaching the lubber line the roll-out is started before the desired heading is reached by the appropriate correction.

A third method of estimating when to roll out relies on timing. Since a Rate 1 turn results in a turn of 360 degrees in 2 minutes, the rate of turn is calculated as 3 degrees per second. Knowing the arc to be turned through, the amount of time required at Rate 1 can be calculated and the turn timed using the aircraft clock. This calculation method, however, is more appropriate to CPL training than basic training.

When the calculated heading to roll out on is seen under the lubber line, roll out **smoothly**. Immediately choose a reference point on the horizon and fly on the reference point, wings level, and balanced. Give the compass time to settle, do not chase the heading.

When reading the compass, ensure that the wings are level and that the aircraft is in steady balanced flight, as these are the **only** conditions under which the compass will read accurately.

Making the Correction

Often the required heading will not have been achieved exactly, so minor corrections will need to be made.

Which Way to Turn?

Because of the way heading information is presented by the magnetic compass it is vital to **read** the compass. The most common errors involve simply turning toward the desired heading or matching the position of the heading indicator on the DI with the lubber line's position.

One method is to reverse the sense. For example, if the required heading is left of the lubber line, turn right. This sounds simple but many students find this method confusing.

Another is for the student to visualise themselves in the centre of the compass rose and looking down the compass heading over the nose of the aircraft. If the compass reads, for example, 038 and the desired heading is 035, that heading is left of the present heading. Do not look at the compass.

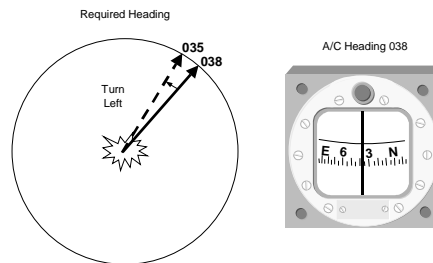

Yet another method is to employ the serviceability check carried out during taxiing, turning right, numbers increase, turning left, numbers decrease. Therefore, a turn from 038 to 035 requires a decrease or left turn. This method has the advantage that nothing new needs to be learnt. But, this method works only for small heading changes or corrections and cannot be applied to the initial turn direction calculation; for example, turning from 030 to 300, the shortest arc is left but numbers increase to the right.

Where more than one method is available to explain a procedure or calculation, it is recommended that you choose only one explanation to deliver to the student. If the student cannot understand that explanation, rather than just repeat it a little louder, you can then use another explanation. Once the student has grasped the principles, other methods of arriving at the same conclusion can be introduced to reinforce learning.

When to Roll Out?

There are two methods available to determine this.

The first, used primarily in instrument flight, relies on timing the turn at 3 degrees per second and is reasonably easy to do for small corrections, 5 to 10 degrees = approximately 2 to 3 seconds. Saying “one thousand” equates to about one second, therefore, once the rate one turn is started, counting rather than timing on the clock is used.

The second, used in a practical VFR sense, is to estimate the required heading change and select a new reference point on the horizon; complete a turn onto the new reference.

In either case, roll out smoothly, maintain balanced level flight on the reference point, and allow the compass time to settle.

Airborne Sequence

During the pre-flight inspection pay particular attention to the serviceability checks of the compass and the validity of the deviation card.

Look at the compass heading before turning the master switch on and the watch the effect of starting the engine.

During the taxiing instrument checks, note that the turn coordinator gives a rate of turn, not the angle of bank, and that the DI can be set to read any heading desired, regardless of the aircraft actual heading.

The airborne sequence starts with a demonstration of acceleration/deceleration errors. Maintaining a heading of 090 or 270 by reference to the DI or reference point, accelerate the

aircraft by smoothly pitching the nose down; note the apparent turn toward the south. This exercise is repeated to demonstrate deceleration effects by smoothly pitching the nose up; note the apparent turn toward the north.

Rapid movements of the throttle to produce this effect (negating all previous engine handling training) is neither required or relevant.

When this exercise is repeated on headings of 000 or 180 no apparent turn will occur, although the compass may be seen to dip. Ensure the aircraft is kept straight by reference to the DI or reference point.

The demonstration of acceleration errors is concluded with a reminder that when accelerating, decelerating or pitching, keep straight on the reference point. In addition, to compensate for turning errors accurately, it will be necessary to avoid pitch changes during the Rate 1 turn.

The fact that turning errors **do** exist when using the compass is next demonstrated by completing a 360 degree Rate 1 turn and noting the difference between the compass heading and the DI on cardinal and intermediate headings. Point out that these errors or corrections are only true in a level, balanced, Rate 1 turn. Start on a compass heading of 090 or 270 (with the DI aligned) and have the student read out the compass heading when you read out a DI heading. In a turn to the right you read out 030 (DI), the student should read out about 010 compass, a 20-degree difference.

Once the errors have been observed, a DI failure is simulated. Using the recommended steps, compass turns onto cardinal headings are practised.

Beware of lookout degradation during calculations.

Commonly, when the aircraft is rolled wings level, there is a tendency by the student to fixate on the compass rather than maintain level flight on a distant reference point. This tendency can be overcome by covering the compass with your hand just as the student starts the roll-out and insisting that they choose and fly a reference point. Allow the compass adequate time to settle, ensure the aircraft is in balanced flight, and then remove your hand to **read** the compass.

Depending on which method is used for minor corrections, cover the compass again and calculate which way to turn. Calculate the time required or choose a new reference, turn and regain balanced level flight. Allow the compass to settle and remove your hand to **read** the compass.

When the compass reads the correct heading, emphasise the reference point to maintain heading. Do not allow the student to fixate on the compass; **instruments are used to confirm performance, not set it.**

COMPASS TURNS

OBJECTIVE:

To turn accurately onto and maintain compass headings, compensating for known errors in the aircraft's magnetic compass.

CONSIDERATIONS:

Errors of the Magnetic Compass

- 1) **Variation:** Difference between True N and Magnetic N (use OHP)
- 2) **Deviation:** Difference between Magnetic Hdg and Compass Hdg
Due to magnetic fields within the cockpit.
- 3) **Dip:** A magnet horizontal over Equator, dips down at the poles.

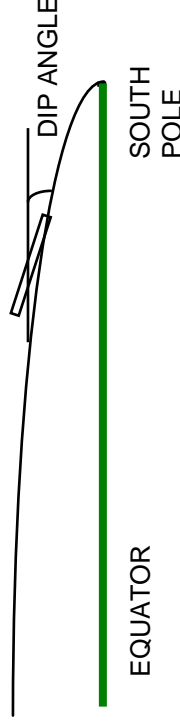

4) Acceleration Errors:

SAND
Maximum on 090 and 270 - Nil on 000 and 180 (dip only)

5) Turning Errors:

ONUS
Maximum on 000 and 180 - Nil on 090 and 270

To correct for turning error, turns must be

Rate One - Balanced - Level - Without pitch changes.

Angle of bank required for Rate One = $TAS / 10$

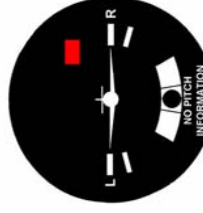

AIR EXERCISE:

- 1) Demo Acceleration Errors - maintain reference point
- 2) Demo Turning Errors
- 3) Corrections for turns onto compass Hdgs (L and R)

Prior to turns - 4 Questions

1. Turn which way Left or Right?
2. Overturn or Underturn?
3. By how much?
4. What is the roll out hdg?

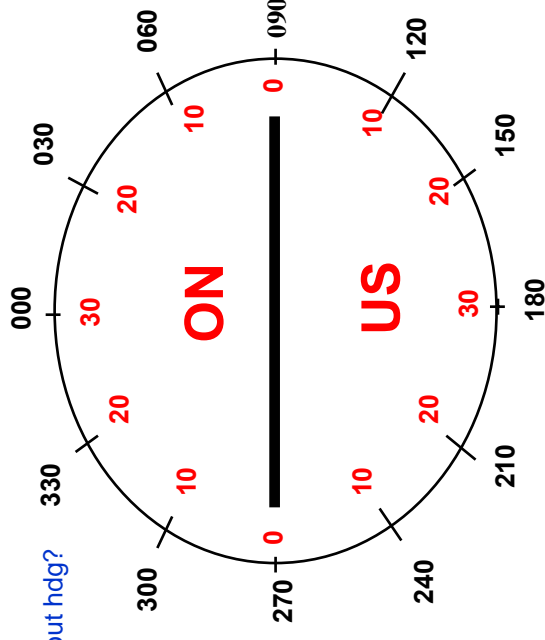

Exit - Roll out smoothly at pre-selected hdg.

- Ref point on horizon
- Let compass settle (liquid swirl)
- In level balanced flight - **read** the compass

To Adjust Heading

Turn which way?

When to roll out? (Rate 1 = 3 degrees/second or select new reference pt.)

Maintain balanced level flight on reference point.

AIRCRAFT MANAGEMENT:

Check Compass for:

deviation card, fluid leaks
bubbles, discolouration
metal or electrical objects
Taxi

Check & Rwy Hdg

Turn Coordinator - (flag)

Vacuum System (4.5 - 5.2"Hg)

HUMAN FACTORS:

Disorientation

Situational awareness

Information Processing

Remove unreliable information

Stress

Practice & procedure

Beware degradation of Lookout

Short-Field Takeoff

This briefing discusses the **application** of the performance data provided in the aircraft Flight Manual and involves operating the aircraft at its safe and legal limit.

The mechanical skills required to execute this exercise are easily taught by any qualified flight instructor. The challenge for you is in developing the student's decision-making processes.

A short (or minimal) field is one where the runway length is shorter than that normally available for the conditions but is still sufficient for takeoff. **It is not one that is too short.** Nor is it one where the runway length is unknown. Sufficient runway length for takeoff **must** be proven **before** takeoff, by reference to the aircraft Flight Manual. Takeoffs are **not** made from runways that are too short!

The complexity of this briefing will be affected by the content of briefings given throughout the circuit phase.

Introduction

When a runway group number is not available, or is available but less than the aircraft group number, reference must be made to the aircraft Flight Manual to ensure that there is adequate runway length available for takeoff under the existing conditions. As a rule, if doubt exists under any circumstances, refer to the Flight Manual.

Performance ('P') charts, where available, are a valuable source of takeoff performance information. Manufacturer's graphs in Flight Manuals should be used in the absence of P-charts. If using the latter, it is recommended that pilots apply the appropriate takeoff surface correction factors (refer AC91-3).

Objectives

1. To ensure by calculation that there is adequate runway length for takeoff in accordance with the aircraft performance data.
2. To apply ADM principles before adopting the recommended procedure for takeoff from a runway of minimal length.
3. To operate the aircraft in accordance with the manufacturer's recommended short-field techniques in order to obtain the best possible takeoff performance.

Considerations

Factors

The various factors affecting the takeoff are discussed (preferably revised) in detail.

Temperature

This affects the air's density. An increase in temperature will result in a decrease in density. Since the expected engine performance is based on a standard temperature of 15 degrees Celsius at sea level, a correction will need to be made for the actual or ambient temperature.

Temperature may also be expressed in relation to ISA (International Standard Atmosphere); for example, a temperature of 15 degrees Celsius at sea level is an ISA standard. Therefore, 17 degrees Celsius at sea level is ISA +2. This method, however, is not common within New Zealand general aviation.

Density

Density affects the indicated airspeed (IAS). As density decreases, IAS decreases. Therefore, as the density decreases, the aircraft's actual speed (TAS) will need to be increased to achieve the same IAS for any given rotate IAS. This **will** increase the length of the takeoff roll, but the effects of density on engine performance are far more critical.

If you are in the aircraft, on the field of takeoff, the aircraft outside air temperature (OAT) gauge gives ambient temperature. Otherwise, this information is provided in a METAR if available.

Pressure Altitude

The calculation of pressure altitude (PA) is vital for takeoff, as this corrects the airfield elevation under the existing conditions to an elevation within the **standard atmosphere**, and the standard atmosphere is what the expected engine performance is based on.

If you're on the aerodrome of takeoff and in the aircraft, you can simply set 1013 hPa on the altimeter sub-scale and read off the pressure altitude. However, if you're not on the aerodrome of takeoff, you need to know the airfield's QNH (METAR) and elevation (aerodrome chart) in order to calculate pressure altitude.

Aircraft Weight

The aircraft weight is derived from the weight and balance calculations and will directly affect the takeoff and climb performance.

Runway Surface

The takeoff roll is reduced on a firm or sealed surface compared to a soft or grass surface, because there is less surface friction. The runway surface may be either observed, or derived from the aerodrome landing chart. Since the takeoff performance figures provided in the aircraft Flight Manual must be calculated using known parameters, a grass surface is defined as short dry grass. Long or wet grass will markedly increase the takeoff distance because of the increased surface friction.

Slope

An up-slope increases the takeoff distance and a down-slope reduces it. The slope of a runway, as a percentage, is given in the operational data on the aerodrome chart.

Headwind Component

When the wind is at an angle to the runway in use, the headwind component will need to be calculated. Use the chart provided in the aircraft Flight Manual.

Calculating the Takeoff Distance

The calculation of the required takeoff or landing distance should not be a complicated process, used only once to meet flight test requirements. It should be a relatively simple process that encourages its regular use and the application of ADM principles.

Students should have been taught how to use performance graphs before undertaking this exercise.

With the necessary information collected, the aircraft Flight Manual is consulted in order to determine the required takeoff distance.

The takeoff performance graphs in most light training aircraft Flight Manuals provide only one weight, all-up weight (AUW). This is because the range of weights for takeoff or landing is insignificant and, since AUW cannot be exceeded, provides a safety margin at lower weights. Larger aircraft Flight Manuals provide two or more weights.

Where only an AUW is given, lesser weights cannot be extrapolated. AUW must be used regardless of the aircraft's actual weight.

Using either: P-charts where available, or the Flight Manual performance data plus AC91-3 surface correction factors, calculate the distance for takeoff under the existing conditions. Compare this with the distance available, as given in the aerodrome chart's operational data, or as determined by other means.

If the takeoff distance available is less than the takeoff distance required, **walk away!**

If the takeoff distance available is equal to or slightly more than the takeoff distance required, **think!**

Double-check your calculations. Have all factors been properly taken into account?

Remember that an accurately performed short-field takeoff will be required in order to ensure that the performance data contained in the Flight Manual is met.

Takeoff performance figures are based on shiny new engines and propellers; how does this aircraft compare? Is the surface short dry grass or a bit long? How important is it that a takeoff be conducted **now**, under these conditions, and how will the conditions be affected by a delay?

The calculated takeoff distance to a height of 50 ft assumes full power is applied before brake release and that the stated flap setting is used. The distance required for takeoff includes the ground roll and the distance travelled over the ground to reach a height of 50 ft at the takeoff safety speed (V_{TOSS}) which is based on the aircraft stall speed and therefore varies with the weight.

The takeoff safety speed (V_{TOSS}) is the speed to be achieved after liftoff and before a climb above 50 ft. Although, for most light training aircraft, it is commonly the same speed as the best angle of climb speed (V_X), if flap is being used the aircraft is often not configured for the **best** angle of climb. (Refer to Flight Manual for manufacturer's recommended procedures; refer CFI.)

Some aircraft Flight Manuals have two takeoff charts, one without flap and another with flap. The use of flap is often recommended for a takeoff from a soft field or where obstacles are present in the climb-out path (refer aircraft Flight Manual). This is because the increase in lift provided by flap allows the aircraft to lift off sooner at a lower airspeed, thereby minimising the ground roll and surface friction.

Commonly, a lower takeoff safety speed (V_{TOSS}) is nominated when flap is used. This is because flap lowers the stalling speed, making a lower takeoff speed possible. In addition, the decreased groundspeed resulting from the lower climb airspeed allows a **similar** angle to best-angle to be achieved.

Takeoff distance calculations should be based on the appropriate performance figures, depending on whether flap is recommended for takeoff or not.

Unless **all** of these are applied with, calculation of the required takeoff distance is negated.

As this exercise is not generally carried out from minimal length fields, remember to advise students that such conditions are being simulated.

Aircraft Management

Full power before brake release is confirmed by checking that the required static rpm is being achieved. This figure (often stated as a range, eg, 2280 to 2380 rpm) is laid down in the Flight Manual.

If static rpm is not achieved, simple ADM should result in a logical sequence of: full power is not achieved therefore, maximum performance cannot be achieved, therefore, the takeoff must not be attempted.

Have an aircraft engineer check out and clear the problem before further flight.

There are a few reasons why static rpm may not be achieved, and consideration of these requires the application of a higher level of ADM.

- **Icing:** Check for carb ice and that the carb heat control is set to COLD. If this cures the problem, continue with the takeoff.
- **Instrument error:** Is this rpm normal for this aircraft? Has this rpm reading been confirmed by the engineers as indicative of full power in this aircraft? (If so, why is this state of affairs acceptable? Refer CFI).
- **Propeller:** Is the propeller in good condition, and is it the same propeller installed by the manufacturer, on which the static rpm is based. Or has it been replaced with a propeller of coarser pitch?

These last two possibilities cannot be confirmed while sitting at the holding point; taxi back to the start-up area and consult an aircraft engineer.

Human Factors

The short-field takeoff is a procedure used to achieve the optimum aircraft performance for takeoff as stated in the aircraft Flight Manual. The stated performance figures are based on the aircraft being operated in accordance with the manufacturer's recommendations (refer CFI and Flight Manual). Therefore, pilots should consider their own ability before attempting a takeoff from a runway of minimum length.

The prime emphasis of this briefing is on **I**nformation processing (ADVISE mnemonic) and decision-making. The decision-making considerations of a normal takeoff apply; but additional decision-making is required in relation to a strong or gusty wind and EFATO.

If strong or gusty winds are present, there is always the possibility of windshear in the climb-out. If a decrease in wind speed is suddenly encountered during takeoff, additional power will not be available to arrest the sink. Therefore, the rotate speed (V_R) and the takeoff safety speed (V_{TOSS}) are increased by an appropriate amount to counter the possible effects of windshear.

For steady wind speeds of 10 kts or less, use the book figures, for example, takeoff safety speed 54 kts.

For winds above 10 kts, this speed is progressively increased (refer CFI and Flight Manual).

Whenever the rotate, takeoff safety speed or best-angle-of-climb speed needs to be increased because of the conditions, think about whether to continue with the exercise.

The possibility of EFATO during a short-field takeoff requires heightened situational awareness and an amendment to the takeoff safety brief. Rather than simply lower the nose, as a result of the very high nose attitude and the low airspeed during the initial climb out, the takeoff safety brief is modified to emphasise **immediately and positively** lower the nose.

Vision will be affected by the high nose attitude and terrain ahead may produce a false horizon. Therefore, regular cross-reference to instruments is emphasised.

In addition, when operating from runways of minimal length, stress levels will be raised as a result of the what-ifs: for example, the possibility of encountering windshear, or of EFATO occurring. During basic training, however, increased stress levels may result only from the requirement to fly the aircraft accurately and the unfamiliar nose-high attitude.

Stress is reduced when operating from runways of minimal length through the application of the rule-based procedures discussed above, modified for personal limits. Stress from carrying out the flight procedure will be reduced through regular practice.

Air Exercise

While holding the aircraft on the brakes (nosewheel straight) with elevator neutral, full power is applied and static rpm as well as temperatures and pressures checked for normal indications.

Good aviation practice dictates that all takeoffs must be made using full runway length.

Ensure a clean brake release, and, as soon as the aircraft starts to move, take the weight off the nosewheel with elevator to reduce surface friction, and check for normal acceleration.

The nosewheel should be held on the ground until the rotate speed (V_R) is achieved. This will require an adjustment to backpressure as the airspeed increases and the elevator becomes more effective. Rotating early only increases the aerodynamic drag and prolongs the takeoff roll.

As V_R is reached, smoothly rotate the aircraft and lift off (do not 'haul' into the air). Lower the nose and allow the aircraft to accelerate to the takeoff safety speed (V_{TOSS}). This generally requires only a small decrease in backpressure rather than a noticeable check forward.

On reaching V_{TOSS} the attitude is adjusted and held. As a result of the high power setting and low airspeed, more rudder than normal will be required to keep straight on the reference point.

At a safe height (assuming that any obstacles have been cleared), accelerate again to best rate of climb (V_Y) or the normal recommended climb speed (refer CFI). Check balance.

Before raising flap (if used), there are three criteria that must always be met: safe height, safe airspeed, and a positive rate of climb. When these conditions have been met, raise flap and counter the pitch change. Allow acceleration to continue, and upon reaching the climb speed required (best rate or normal), trim to maintain the appropriate attitude.

Airborne Sequence

The distance required for takeoff has been determined as adequate, and flap has been selected in accordance with the aircraft Flight Manual.

Before Line-Up

The conditions are assessed and compared with the conditions that were used in calculating the required takeoff distance.

A decision is made on the rotate and takeoff safety speed for the existing conditions.

A safe height, at which to accelerate to best rate or the normal climb speed, is nominated dependent on the height of obstacles in the climb-out path. An obstacle clearance altitude

(OCA) is stated, rather than a height above ground, as an altitude is what the student will see on the altimeter.

The OCA should be varied during subsequent exercises to simulate clearing various obstacles in the climb-out path.

The pre-takeoff safety brief is completed, with emphasis on a positive check forward, in the event of EFATO.

On Line-Up

Full runway length is used, and the high reference point is chosen.

If propeller damage is a possibility because of a loose surface, the aircraft is not held on the brakes. The minimum static rpm is confirmed as soon as full power is applied. At the point of brakes release, always check that the student drops his or her heels to the floor.

Do not allow the student to round off the rotate or takeoff safety speed to the nearest mark on the airspeed indicator, for example, takeoff safety speed 54 kts, which is “near enough to 55 kts”. This exercise requires accurate flying skills, and these only come from practice.

Although one knot may make no appreciable difference to the aircraft performance, this practice will ultimately make a considerable difference to the student’s attitude to performance.

SHORT-FIELD TAKEOFF

OBJECTIVES:

1. To ensure by calculation that there is adequate runway length for take-off in accordance with the aircraft's performance data.
2. To apply ADM principles before adopting the recommended procedure for take-off from a runway of minimal length.
3. To operate the aircraft in accordance with the manufacturer's recommended short-field techniques in order to obtain the best possible takeoff performance

CONSIDERATIONS:

Why Rwy group number unavailable or less than A/C group number

Takeoff Affected by

Temperature } Density Altitude
 Pressure Altitude }
 Weight }
 Surface (Note: Grass means - short dry grass)
 Slope

Use a proforma to compile this information

Headwind Component
 Is the distance required, available? If so, what safety margin is available?

Takeoff Distance Required Is Based on

A/C, engine, propeller combination
 A climb to 50 feet
 Takeoff safety speed at 50' ___kts
Full power prior to brakes release
 Flap setting as appropriate (refer A/C flight manual)

Soft Field Takeoff

Flap is often recommended to reduce the ground roll (refer A/C flight manual).

AIRCRAFT MANAGEMENT:

Static RPM: achieved

Carb ice? Instrument error?

Propeller condition?

Continue or Abort?

Density Altitude - Lean Mixture?

Prior to T/O - Check T's and P's

Estimate lift-off point.

AIR EXERCISE:

Plan Prior to Line Up

Adequate runway length proven, Vr, Vtoss & obstacle clearance altitude (OCA) nominated for conditions.

Decision - Go, No Go?

Takeoff brief (EFATO).

- 1) Use full runway length
 Flap (as required)
 Full power against brakes (static rpm, T's and P's)
 Elevator neutral
 Release brakes, keep straight (more rudder req.)
 Take weight off nosewheel with back pressure
 Check acceleration normal
- 2) At ___ kts (refer A/C manual), **rotate**
- 3) Airborne, lower nose & **accelerate** to ___kts (Vx)
- 4) At ___kts (Vx) **climb** (more rudder req.)
- 5) Above OCA, **accelerate** (reduce rudder)

If flap was selected for T/O

When above OCA, accelerating, with a positive rate of climb
 Raise flap

- 6) Accelerate to ___ knots, **climb** at best rate (Vy)

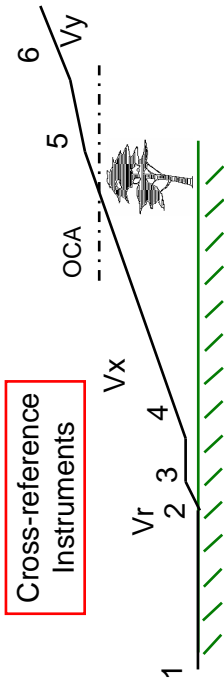

HUMAN FACTORS:

Vision - Orientation

High nose attitude, High ref pt

Personal Limits

Information Processing - Decision Making

Add increment for wind shear, Go or Abort?

EFATO - immediately and positively lower nose

Stress Will reduce with regular practice

Short-Field Landing

This briefing discusses the **application** of the landing performance data provided in the aircraft Flight Manual.

As with the maximum performance takeoff, developing the student's decision-making processes in relation to landing on runways of minimal length provides a real challenge for the professional flight instructor.

The emphasis of **this** briefing is on an approach and landing into a runway of minimal length, where the runway length available is shorter than that normally available for the conditions but is still sufficient for landing. **It is not one that is too short.** Nor is it one where the runway length is unknown. It is a normal operational procedure. Sufficient runway length for landing **is proven before** the approach is started, by checking the aircraft Flight Manual.

An approach to a field where the runway length is unknown, or is known to be too short, may occur during the precautionary landing. This is an emergency procedure, but the approach technique is the same as for a short-field landing.

Introduction

When the runway group number is unavailable or is available but is less than the aircraft's, reference must be made to the Flight Manual to ensure that there is adequate runway length available for landing under the existing conditions. As a rule, if doubt exists under any circumstances, refer to the Flight Manual.

This lesson details how to comply with the requirements for landing calculations.

Performance charts, where available, are a valuable source of landing performance information. Manufacturer's graphs in Flight Manuals should be used in the absence of P-charts. If using the latter, it is recommended that pilots apply the appropriate landing surface correction factors (refer AC91-3)

Objectives

1. To ensure (by calculation) that there is adequate runway length for landing in accordance with the aircraft performance data.
2. To apply aeronautical decision-making (ADM) principles before adopting the recommended approach procedure for a runway of minimal length.
3. To operate the aircraft in accordance with the manufacturer's recommended short-field techniques, safely complete the approach and landing, and stop within the distance calculated.

Considerations

Factors

The various factors affecting the exercise are discussed (preferably revised) in detail.

Aerodrome Elevation or Pressure Altitude

Because of the low power setting used on the approach, aerodrome elevation is used when calculating landing distance and the effects of pressure altitude ignored. However, an increase in altitude will result in a decrease in the air density. As density decreases, IAS

decreases and the aircraft's actual speed (TAS) will be increased for any given indicated threshold crossing speed. Therefore, the airfield height above sea level will affect the length of the landing roll, and pressure altitude may be used for more accurate calculations (refer Flight Manual and CFI).

Aircraft Weight

The aircraft weight affects inertia and therefore the stopping distance.

Runway Surface

The landing roll is reduced on a firm dry surface compared with a grass or wet surface because of the improved braking action. Remember that grass is defined as short dry grass.

Slope

An up-slope decreases the landing distance, and a down-slope increases it. Slope is given in the aerodrome operational data.

Headwind Component

When the wind is at an angle to the runway in use, the headwind component will need to be calculated. Use the chart provided in the aircraft Flight Manual.

Calculating the Landing Distance

Students should have been taught how to use performance graphs before undertaking this exercise.

With the necessary information collected, the aircraft Flight Manual is consulted in order to determine the landing distance required.

The calculated distance for landing, under the existing conditions, is compared to that available, which is given in the aerodrome chart's operational data.

If the landing distance available is less than the landing distance required, **walk or fly away!**

If the landing distance available is equal to or slightly more than the landing distance required, **think!**

Double-check your calculations. Have all factors been properly taken into account?

Remember that an accurately performed short-field landing will be required in order to ensure that the performance data contained in the Flight Manual is met.

The Flight Manual for each aircraft type states the maximum speed for crossing the threshold, and the flap setting to be used.

The required landing distance laid down in the aircraft Flight Manual is calculated from a height of 50 ft above the threshold in the stated configuration. That is, the distance required for landing includes the distance to touch down from 50 ft over the threshold and the ground roll to a full stop.

Crossing the threshold higher than 50 ft using less than full flap, or crossing the threshold at a higher airspeed than stated in the Flight Manual, will increase the calculated landing distance.

It is very difficult, if not impossible, to judge exactly 50 ft, so, in practical terms, if the outcome of the approach and landing is successful, you must have been close to 50 ft at the threshold!

Aircraft Management

In preparing the aircraft for landing, it is recommended that at least three legs of the circuit (starting downwind) are flown.

If the aircraft is not properly configured by 200 ft agl on final approach – that is, on centre-line, on correct glideslope, aim point identified, and airspeed correct – **go-around!**

In addition, the threshold target speed (V_{TT}) for the conditions, and an aim point on the runway, are nominated. The aim point should be as close to the threshold as is safe (consider obstacles on approach). If the exercise is being flown onto a marked runway, a point just short of the numbers painted on the surface is a good choice as an aim point.

The selection of this aiming point should not be confused with the club competition of spot landings, where the objective is to land on a spot, usually well into the runway. Although the same approach technique is employed, nominating an aiming point well into a field of minimal length would negate the landing distance calculations.

Human Factors

During an approach to land, perception may be influenced by the visual cues of surrounding terrain, a false horizon or runway length and width¹⁵⁶ (use OHP). Therefore, regular cross-reference to instruments is emphasised.

The procedure to achieve the optimum aircraft performance for landing as stated in the Flight Manual is used. The stated performance figures are based on the aircraft being operated at its optimum. Therefore, pilots should also consider their own abilities before attempting a landing on a runway of minimal length.

The prime emphasis of this briefing is on **I**nformation processing (ADVISE mnemonic) and decision-making. The decision-making considerations of a normal approach apply, but additional decision-making is required in strong or gusty wind conditions.

If strong or gusty winds are present, there is always the possibility of windshear on the approach. The approach and target threshold speeds (V_{TT}) are increased by an appropriate amount to counter the possible effects of windshear.

For steady wind speeds of 10 kts or less, use the book figures.

For winds above 10 kts, this speed is progressively increased (refer CFI and Flight Manual).

Whenever the approach or threshold speed needs to be modified, consider whether to continue with the exercise. The answer may be affected by the excess runway available over that required.

When operating into runways of minimal length, stress levels may be raised. During basic training, however, increased stress levels may result only from the requirements to fly the aircraft accurately and at lower than normal airspeeds.

Stress is reduced when operating into runways of minimal length by applying the procedures as discussed above. Stress from carrying out the short-field approaches and landings will reduce with regular practice.

¹⁵⁶ Ewing, 1993

Air Exercise

On the downwind leg, the conditions used for the approach and threshold speeds are confirmed and an aim point chosen.

The turn onto base is carried out in the normal manner but delayed slightly by extending the downwind leg to ensure some power must be used **throughout** the entire approach.

Because the this type of approach employs a low threshold speed, a heavy aircraft with considerable inertia may not have sufficient elevator effectiveness to initiate the flare even though full elevator deflection may be used. Using power throughout the approach gives total control over the rate of descent and additional elevator effectiveness during the flare.

The approach path is monitored by reference to the aiming point and the power adjusted as required to maintain a steady rate of descent to touch down – power controls the rate of descent¹⁵⁷. If the aircraft is correctly trimmed the power adjustments will be very small.

Once established on final, full flap is selected and the airspeed progressively decreased, through attitude adjustment, to achieve the nominated target threshold speed (V_{TT}) by about 200 ft agl. Power will generally need to be adjusted as speed is decreased.

It is important to carry some power into the flare.

The landing is carried out in **one** phase. The round-out and the hold-off are combined into the flare (a reduction in rate of descent to zero). The aim is to reduce the rate of sink to zero at the same time as the main wheels touch the ground and the throttle is closed.

The nosewheel is lowered, **then** brakes immediately applied **as required**; elevator backpressure is used to keep the weight off the nosewheel. Do not use excessive brake!

Flap is raised on completion of the landing roll.

Airborne Sequence

Except for extending downwind a little to ensure power is used throughout the entire approach, the turn to base, base leg and the turn to final are all normal.

On final (looking a little low, due to the downwind extension) full flap is selected.

The airspeed is progressively reduced to the nominated target threshold speed by 200 ft agl.

To reduce the airspeed, the nose attitude will need to be raised, and this usually results in the student assessing the approach as high, with a consequent immediate reduction in power. During a normal approach the aircraft is flown down the approach path at 70 kts, whereas during this exercise the aircraft sinks down the same or steeper approach path at progressively decreasing speeds, only the attitude and airspeed are different. The approach profile should never be flat and low.

The importance of selecting an attitude for the required speed, particularly the V_{TT} , and trimming the aircraft to maintain that attitude, cannot be over emphasised.

If the aircraft is not properly configured by 200 ft agl, on centre-line, on glide slope, aim point identified, and airspeed correct – or the landing is not assured for any reason – the student should be taught to **go-around**.

¹⁵⁷ Campbell, 1994, p.13-19

Do not allow the student to round off the approach or target threshold speed to the nearest mark on the airspeed indicator.

A full-stop landing should always be made when flying this exercise.

Although this exercise may be incorporated with the short-field takeoff, it is recommended that the exercises be introduced separately in order to avoid student information overload.

SHORT-FIELD LANDING

OBJECTIVES:

1. To ensure (by calculation) that there is adequate runway length for landing in accordance with the aircraft's performance data.
2. To apply ADM principles before adopting the recommended approach procedure for a runway of minimal length.
3. To operate the aircraft in accordance with the manufacturer's recommended short-field techniques safely complete the approach and landing and stop within the distance calculated

CONSIDERATIONS:

Why Rwy group number unavailable or less than A/C group number

Landing Affected by

Elevation/Pressure Altitude

Weight

Surface (Note: Grass means - short dry grass)

Slope

Headwind Component

Is the distance required available?

If so, what safety margin is available?

Landing Distance Required Is Based on

A/C threshold crossing speed and flap setting

Threshold speed ___kts.

Full Flap

A threshold crossing height of approximately 50 feet

Use a proforma to compile this information

AIR EXERCISE:

- 1) **Downwind** Asses the conditions
Nominate approach and target threshold speeds (V_{tt})
Nominate decision altitude and aim point
Extend downwind
- 2) **Turn to Base** Use normal power, flap and approach airspeed
- 3) **On Base** Select additional flap (if applicable)
Maintain approach speed - trim
- 4) **On Final** Full flap
Adjust attitude to  airspeed to V_{tt} at decision alt. (200')
Trim
Monitor the approach path by reference to the aim point
Power as required to maintain a steady rate of descent
If the A/C is correctly trimmed, power adjustments will be very small.
- 5) **Decision Altitude** - On Approach
- On Centreline
- On Speed
} **If not, Go-around**
- 6) **Landing**
- Flare to reduce ROD to zero on touchdown
- Close throttle
- Lower nosewheel
- Braking as required, keep weight off nosewheel

AIRCRAFT MANAGEMENT:

Fly 3 circuit legs

Select aim point

Nominate target threshold speed

HUMAN FACTORS:

Vision Terrain, False Horizon

Runway width & length

Personal Limits

Info Process - Decision Making

Add increment for wind shear,
Go or Abort?

Stress Will reduce with regular practice

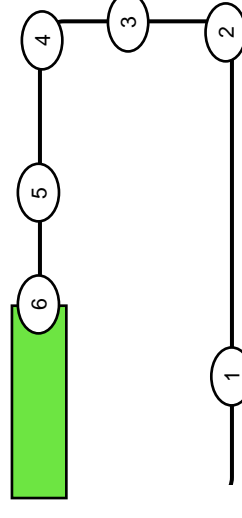

Low Flying – Introduction

This briefing introduces the student to the poor-visibility configuration and demonstrates the visual illusions resulting from drift and inertia.

Low flying is an exercise used to develop the student's situational awareness, not only of the visual and physical effects of wind and terrain, but to avoid the situation completely and **never fly lower than they must.**

The various considerations of operating the aircraft at minimum height are spread over two low-flying briefings and the precautionary landing briefing. The considerations included in these briefings are only a guide, and the decision to include or defer them is at the CFI's discretion.

Introduction

Commonly, low flying refers to any flight at or below 500 ft agl that may be practised only in designated low-flying zones (formerly called low-flying areas).

By maintaining situational awareness, it should be possible to avoid the operational need for low flying, for example, as a result of weather. Pilots need to be familiar with flying low in order to observe the effects of inertia, to experience the visual illusions caused by drift and a false horizon, and to recognise that the stress of low flying is a situation to avoid.

This and subsequent low-flying briefings and exercises discuss the relevant procedures to be adopted in the event of being forced to fly low as a result of continuing into deteriorating weather. These lessons will not make anyone an expert at low flying, nor do they condone the practise as a regular manoeuvre. Setting personal limits well above the legal minimum, always leaving a way out, and turning back or landing at the nearest suitable aerodrome long before the situation simulated in this exercise is reached – cannot be stressed enough.

Better to be on the ground wishing you were flying, than airborne wishing you were on the ground!

Objective

To compensate for the effects of visual illusions, inertia, and stress when operating the aircraft close to the ground.

Considerations

Inertia

The effects of inertia and the sensation of speed become most apparent at low level. At normal cruise speeds the degree of anticipation and the amount of horizontal airspace required to turn the aircraft is substantial.

Visual Effects

The effect of wind is very apparent at low level and this can lead to quite powerful visual illusions.

When flying into wind at a constant airspeed the groundspeed is low and this can lead the student into either lowering the nose or increasing power.

Downwind the groundspeed is high and this may result in the nose attitude being raised or power reduced.

When flying across the wind the effect of drift is most noticeable. A suitable reference point on track must be chosen. In order to track towards this reference point, the appropriate amount of drift must be offset and balanced flight maintained. Avoid any tendency to fly with crossed controls.

When turning from into-wind to downwind an illusion of slipping into the turn will occur and likewise, when turning from downwind into the wind, an illusion of skidding out of the turn will occur. The strength of this illusion increases in proportion to the wind strength. Never attempt to correct an apparent skid or slip with rudder. Cross-reference to the balance indicator during low-level flight is vital.

Many designated low-flying zones within New Zealand are over water, and flight over calm water, with its lack of texture, produces depth perception problems (empty field myopia). For this reason, low-level flight over water in less than 10 kts of wind is not recommended.

Aircraft Management

The considerations have been spread over two briefings (and may be interchanged as appropriate, refer CFI).

Low flying must take place within the boundaries of a designated low-flying zone. The boundaries of the area should be described with reference to a map or terminal chart (OHP) and the minimum descent height stated. **Flight below 200 ft agl is not recommended (refer CFI).**

Low-level flight over water is not recommended in winds of less than 10 kts. If low-level flight is to be conducted over water, lifejackets should be worn, not just carried in the aircraft.

A broadcast or report, including the estimated elapsed time (EET) to be spent in the area must be made on entering – and a vacating report when leaving.

When flying close to the ground, if the aircraft's high speed and inertia are combined with conditions of poor visibility, there is little time to react to obstacles or plan a course of action. Therefore, to better manage the flight, the use of the poor-visibility configuration is recommended.

The use of the term poor visibility rather than bad weather configuration is recommended, because bad weather is not necessarily perceived by the student as poor visibility; for example, turbulence. If the weather is otherwise fine but the aircraft is experiencing severe turbulence (where the aircraft structural load limits may be exceeded), the student may consider this to be bad weather (not wrong!). However, in such situations, if the poor-visibility configuration is selected, extending flap usually reduces the aircraft maximum structural load limits (refer Flight Manual).

The poor-visibility configuration for your aircraft should be stated and its benefits explained.

In the poor-visibility configuration, the airspeed is reduced, flap is extended (generally 15 to 20 degrees depending on aircraft type (refer CFI). The benefits are as follows.

Reduced Airspeed

This means less inertia and a lower groundspeed, allowing more time to think and react to obstacles as well as reducing the radius of turns.

Flap

Flap increases the lift and drag and adversely affects the L/D ratio. The increased lift results in a decreased stall speed, allowing safe flight at the lower airspeed. The adversely affected

L/D ratio means a relatively high power setting must be used to maintain straight-and-level flight.

Power

Maintaining the rpm in the normal range means that the continuous use of carb heat is not required, and operating temperatures and pressures should remain within their normal ranges. However, prolonged use of this configuration may lead to increasing oil temperature.

Power also reduces the stall speed and provides slipstream. Slipstream not only provides additional effectiveness to the rudder and elevator (for most aircraft) but also helps to clear the windscreen in drizzle.

Power must always be **increased** in turns. The level of power required increases as the angle of bank increases.

Although the use of this configuration in conditions of poor visibility is good management of the aircraft resources, good management of the total flight would negate the need for its use.

Management of the exercise requires a careful inspection of the low-flying zone and preparation of the aircraft before entering the area.

For this purpose, many organisations adapt the HASELL checklist, adding an extra **L** for lights (refer CFI).

H – Height: Not below (commonly) 200 ft agl (refer CFI).

A – Airframe: As with stalling, common practice is simply to state the configuration that will be used.

S – Security: A loose article check is made and harness secured (life jackets?).

E – Engine: Fuel on fullest tank, fuel pump on, mixture rich and a full SADIE check is completed. Carb heat is cycled more often throughout low flying.

L – Location: The boundaries of the low-flying zone are positively identified.

L – Look-in: Look into the area for indications of wind direction and strength, possible causes of turbulence (tall trees or cliffs) and down-draughts, other aircraft, birds, obstructions (especially wires) and suitable forced landing sites – as little time for field selection will be available from low level.

L – Lights: Turn on all external lights, especially the landing light.

Since ordinarily there would only be one aircraft in the low-flying zone, the student may be wondering, why turn on the landing light? The reason is that birds have been shown to be more sensitive to bright lights than moving objects. This is one reason why landing lights are commonly used below 1000 ft during takeoff and approach.

Human Factors

The effects (ADVISE mnemonic) of **A**ltitude, **D**isorientation, **V**ision, **I**nformation processing and **S**tress are the prime considerations in this briefing.

Some of the visual and disorientating effects of low-level flight have been discussed in the considerations section. In addition, the difficulty of detecting obstructions at low level (wires, birds) against a cluttered background should be discussed.

Information processing is inhibited by stress. Flying the aircraft close to the ground in poor visibility is an extremely stressful situation. The poor-visibility configuration is recommended to increase time available for processing.

There are two strategies for dealing with stress. Confront the cause and deal with it, or remove yourself from the situation, ie, fight or flight. The latter is the recommended strategy for flight at low level in conditions of poor visibility. Through good aviation practice and situational awareness **avoid bad weather, which will eliminate the need for low flying altogether.**

High stress levels result in a decrease in performance and may cause a narrowing of attention by fixating on one instrument or aspect, and/or hyperventilation.

Air Exercise

The air exercise encompasses familiarisation with the low-flying zone boundaries, the effects of inertia, an introduction to the poor-visibility configuration, and the visual illusions created by drift.

When the checks are finished, the low-flying zone is entered using a low rate of descent. A powered descent is recommended.

At 500 ft agl (or lower, refer CFI) in normal cruise, the effects of inertia should become apparent.

The poor-visibility configuration is selected as a management technique.

In this configuration, the effect of visual illusions created by flying across the wind, downwind and upwind are demonstrated. In addition, the visual effects of slipping into the turn when turning downwind and skidding out of the turn when turning into wind are demonstrated.

Level medium turns through 360 degrees **may** also be practised (refer CFI).

Airborne Sequence

The low-flying zone should be identified by flying around the **outside** of the boundaries, at a minimum of 1000 ft agl, keeping it on the port or student's side so that the student can **look into** the area.

Before descent, the necessary checks are completed and intentions advised.

The effects of inertia, resulting in a large turning radius and requiring anticipation, are demonstrated in the normal cruise configuration at 500 ft agl (or lower, refer CFI). This is best achieved by having the student follow a winding road or river. If these features are not available within your low-flying zone, flying around the boundaries at 500 ft agl may substitute. Alternatively, over unpopulated areas within the normal training area, a descent to 500 ft agl to demonstrate these effects before the low-flying exercise **may** be convenient (refer CFI). Note that the visual impression of greater speed becomes more noticeable as height is reduced.

At 500 ft agl, the nominated configuration speed for the aircraft type is specified ____ kts (refer CFI), and the aircraft is placed in the poor-visibility configuration.

To enter the poor-visibility configuration, reduce the power to ____ rpm (refer CFI) and maintain straight-and-level flight.

When the airspeed has reduced to a level inside the white arc, lower the flap to ____ degrees (refer CFI), and as the airspeed approaches the nominated configuration speed, power is increased as required to maintain straight-and-level flight at the nominated speed. Trim.

The level to which the power will need to be increased varies depending on the aircraft weight and other factors. At typical training weight and configuration in the _____ type, this setting will be **about** ____ rpm.

An alternative method of entry may be used. You will set the aircraft up in straight-and-level flight at the nominated configuration speed and without flap. This will demonstrate how the resulting nose-high attitude affects forward vision. When flap is applied, the nose will need to be lowered, and, by careful use of elevator and increased power, the aircraft will continue in straight-and-level flight in the new configuration at the same nominated speed.

This will usually be the first time the student has ever flown the aircraft level in this configuration. Therefore, allow adequate time for student practice (usually at 500 ft agl, refer CFI).

The visual illusions caused by drift on ***track made good*** are first demonstrated by flying along a line feature at right angles to the wind. Crossing the aircraft controls is avoided by the choice of a reference point on which to maintain level balanced flight, to negate the effects of drift, and regular cross-reference to instruments – especially balance.

The effects of groundspeed changes and apparent slip or skid are commonly demonstrated by establishing a race track or circuit type pattern at less than 500 ft agl.

Medium level turns are practised in this configuration as part of the race track or circuit pattern. Medium level turns through 360 degrees may also be practised (refer CFI).

On completion of the exercise you may gain some insight into whether or not transfer of learning has occurred by simply asking the student to "take me home".

The student has been previously taught that, before raising flap, there are three criteria that must always be met: safe height, safe airspeed (above a minimum and accelerating) and a positive rate of climb. These will be achieved only by using full power!

Returning the aircraft to the clean configuration, in anticipation of a climb out of the low-flying zone should be treated as a go-around.

Whether the designated low-flying zone is over water or not, the value of this introduction to low flying lesson is doubtful if winds are less than 10 kts.

LOW FLYING - INTRODUCTION

OBJECTIVE:

To compensate for the effects of inertia, visual illusions and stress when operating the aircraft in close proximity to the ground.

CONSIDERATIONS:

Inertia - Lag in response of the aircraft to pilot input
 - Very noticeable at low level
 - **Anticipate**

Wind Optical illusions in straight and level

 Headwind - Low **G/S** avoid lowering nose or increasing power

 Downwind - High **G/S** avoid raising nose or decreasing power

 Crosswind - Drift, avoid crossed controls, select ref point, offset drift

Illusions during turning



Skid out



Slip in

Calm Water May cause lack of depth perception

AIRCRAFT MANAGEMENT:

LFA Boundaries (OHP)
 Min Alt (refer C.F.I.) 200' AGL
 Over water - Wind > 10 knots
 (Life Jackets?)
 Report entering, duration & leaving LFA
 Poor visibility configuration for this A/C
 is ___ kts, ___ flap, pwr as required
 Explain the benefits of:
 Low A/S, Flap setting and Power
 HASELL

HUMAN FACTORS:

Vision Wires, birds, background
Info Processing
 Inhibited by stress
Stress 'Fight or Flight'
 - Affects performance
 - Narrows attention
 - May cause hyperventilation
 - Maintain situational awareness
 Avoid need for low flying

AIR EXERCISE:

1) Familiarisation of the LFA Boundaries

Complete **HASELL** checks
 Enter LFA using powered descent

2) Demonstration of Inertia

Regain S&L at 500' AGL in normal cruise
 Note reaction time required and turn radius

3) Poor Visibility Configuration

___ knots
 Recommended flap setting ___ degrees
 Power as required to maintain nominated S&L airspeed
 approx ___ rpm

4) Visual Illusions

Crosswind

Note drift (crab angle)
 Ensure balanced flight

Upwind

Downwind

Turning

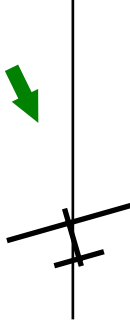

High Groundspeed

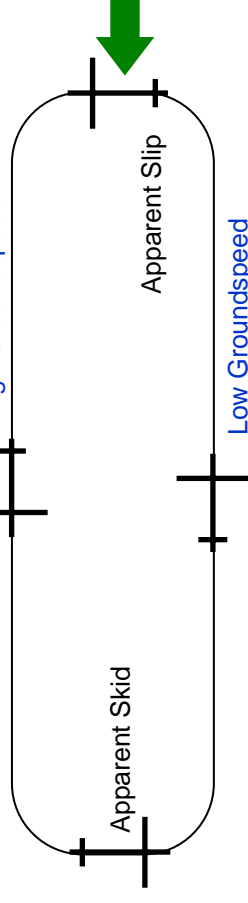

Apparent Skid

Apparent Slip

Low Groundspeed

Use instrument/visual scan and ensure balanced flight

Low Flying – Consolidation

This briefing consolidates the earlier exercise and discusses the various types of turns made while in the poor-visibility configuration and the reasons for making them.

The constant radius turn is a requirement of the CPL syllabus and may be left out or included at CFI discretion.

Introduction

Turning at low level while in the poor-visibility configuration is slightly different from turning in the cruise at altitude. When turning during the cruise at altitude, a reduction in airspeed or some altitude loss is not necessarily dangerous. However, at low level and low airspeed, in the poor-visibility configuration, it is vital to maintain altitude **and** airspeed.

The reason you need to practice turning at low level is to improve confidence and flying accuracy, as well as to prepare against the possible need of operating in deteriorating weather.

Maintaining situational awareness to avoid the need for these techniques cannot be overstressed.

Objectives

1. To compensate for the effects of inertia, visual illusions and stress when operating the aircraft in close proximity to the ground.
2. To carry out various level turns in the poor-visibility configuration in response to deteriorating weather.

Considerations

Map Reading

The look of ground features is changed from a plan view to more of a profile view. This can make map reading and navigation more difficult and in hilly terrain may obscure the true horizon. In this situation, the horizon will need to be estimated and more frequent cross-reference to instruments made to confirm performance.

Sloping Terrain

During flight at low level, height above ground is estimated visually, and the altimeter is used as a secondary reference.

A dangerous visual illusion may occur when flying over gently rising terrain. As the ground gradually slopes upwards, there is a tendency to align the aircraft with the slope so that the impression of level flight is maintained. If the airspeed indicator and altimeter are not cross-referenced regularly, the aircraft may eventually be brought to the stall. This situation can be particularly dangerous if only the reduction in airspeed is observed. In an attempt to compensate for the decreasing airspeed, the pilot increases the power, until a turn away from rising terrain is forced on the pilot at low airspeed and full power – usually resulting in a stall in the turn.

Turbulence

Turbulence at low level is generally more pronounced, and the effects of updraughts and downdraughts more significant.

Avoid flying in the lee of hills or the centre of valleys. Turbulence and downdraughts are most pronounced in the lee of hilly terrain. Avoid the centre of a valley because, if a decision to turn back is made, regardless of which way the turn is executed, the maximum turning space will not be available.

Fly on the upwind side of hilly terrain, or updraught side of valleys, where **relatively** smooth updraughts can be expected. Moreover, if a turn back is required, the full width of the valley is available for turning, and the turn will be into wind, thus minimising the turn radius. Return to the updraught side of the valley after finishing the turn.

Crossing Obstacles

Power lines should always be crossed at the pylons. The pylons are easier to see, and there can be no wires above the pylons or the aircraft. Many high-tension power lines have a very thin earthing wire stretched between the pylons, well above the main cables. It is very difficult to see.

Ridges should always be crossed at an oblique angle. This method requires less bank angle if a turn away from rapidly rising terrain or downdraughts is required.

Aircraft Management

The boundaries of the low-flying zone (formerly called low-flying area) and the minimum permissible height are revised (OHP suggested).

Solo flights must be **specifically and individually authorised immediately before** the intended flight.

Some organisations do not permit solo low-flying practice at all (refer CFI).

For authorised solo flights in a low-flying zone, the Civil Aviation Rules require that the pilot-in-command must be “satisfied that there are no other aircraft in the area”.

Revise flight over water if applicable.

Make a careful inspection of the low-flying zone, and prepare the aircraft before entering the area (HASELLL).

A broadcast or report, including the estimated elapsed time to be spent in the area, must be made on entering the low-flying zone; a vacating report must be made when leaving.

The poor-visibility configuration for your aircraft should be re-stated (revise the benefits at your discretion). Re-emphasise that good management of the total flight should negate the need for using the poor-visibility configuration.

Prolonged use of the poor-visibility configuration may affect flight planning (fuel reserves or daylight) and engine operating temperatures. Use SADIE more frequently.

Human Factors

The effects (ADVISE mnemonic) of **A**ltitude, **V**ision and **S**tress are the prime considerations in this briefing.

Be aware of the visual illusions created by drift, and maintain a regular crosscheck of instruments, especially the balance indicator.

Avoid stress through maintaining situational awareness so as to avoid the operational need for low flying.

Air Exercise

Medium Turn

When entering a medium turn in normal cruise, the angle of attack is increased through the application of backpressure to maintain height, and the reduction in airspeed is ignored, for example, 90 kts reduces to 87 kts.

When turning, even at medium angles of bank, in the poor-visibility configuration, no reduction in airspeed is acceptable. Therefore, in order to maintain the nominated configuration speed, increase power.

The required power increase for a medium turn is generally quite small.

Steep Turn

Steep turns in the poor-visibility configuration are generally restricted to a maximum of 45 degrees angle of bank. There are two reasons for this.

Firstly, the increase in drag and the stalling speed are not proportional to angle of bank but are exponential. Therefore, as the angle of bank increases beyond 45 degrees, both the stalling speed and drag **rapidly** increase.

With the aircraft already operating at a low airspeed, there is little margin for an increase in the stalling speed. In addition, the amount of power required to maintain altitude at angles of bank greater than 45 degrees **may not** be available as a result of the rapidly increasing drag.

The second reason involves the aircraft structural limits. Most aircraft have a reduced maximum G-load limit when flap is extended; for example, the PA38 is limited to +2.0 G when flap is extended. This G loading is reached at an angle of bank of 60 degrees. When entering the steep turn from normal cruise, backpressure is increased to maintain altitude and, although the increase in drag is not ignored beyond 30 degrees angle of bank, some decrease in airspeed as a result of the substantially increased drag is expected and acceptable.

When entering the steep turn at low level in the poor-visibility configuration, however, absolutely no decrease in airspeed is acceptable, because of the small margin over the stalling speed.

So as to maintain this margin over the stall speed, power is increased on entry; the power increase required may be substantial, although **not necessarily** full power.

During the turn, attitude, angle of bank, speed, and balance are monitored.

If altitude is being lost, reduce the angle of bank, increase power if necessary. If **full** power has been applied and altitude is still being lost, there is only one option available – further decrease the angle of bank – quickly!

On exiting the turn, power is reduced in anticipation **during** the rollout, keeping the airspeed constant.

Obstacle Avoidance or Reversal Turn

This is a 180-degree turn to avoid an obstacle ahead.

It is common practice during basic training to simulate the worst case scenario. Therefore, this exercise assumes a line feature is being followed (road, river or railway line) in conditions of poor visibility and an obstacle appears ahead, or a decision to turn back is made. A steep turn through 180 degrees to cross the line feature and follow it back is recommended (**an allowance for drift may be required**).

Note, however, that an earlier decision to turn back, probably in conditions of better visibility, may have required only a medium turn.

Coastal Reversal Turn

Once again the worst case scenario is simulated. An obstruction ahead or weather requires a turn back when the feature being followed is the coastline. Simulated poor visibility means no definable horizon is available seaward, and the coastal terrain is simulated as being higher than the aircraft.

The aim of this manoeuvre is to keep the reference (the coast) in sight throughout the turn to seaward and then track back along the coast in the opposite direction.

This procedure should not be confused with an instrument procedural turn. The coastal reversal turn is a totally visual procedure, with cross-reference to instruments being only for accurate flight. Throughout the procedure, the reference (the coast) **must** be kept in sight.

The wind direction and strength will determine what heading is chosen to track away from the coast to provide enough space to complete the reversal turn.

With the wind parallel to the coast (head or tailwind), a turn away from the coast of **about** 45 degrees is recommended. This **may** be backed up by a DI heading or simply estimated. Keep the coast reference in sight and track out far enough to ensure sufficient space to complete the turn.

If the wind is offshore, and depending on wind strength, tracking out at a lesser angle and/or a shorter time is used to remain closer to the coast while still ensuring sufficient space to complete the turn.

If the wind is onshore, tracking out at a larger angle is not **generally** recommended because of the difficulty in keeping the reference in sight. However, if the coastal terrain so dictates, there will be no choice. This is a good reason to turn back well before the situation deteriorates to this degree.

The angle of bank used in the initial turn away from the coast will be influenced by the pilot's ability to keep the reference in sight. If the coastline is on the lefthand side a larger angle of bank can be used than if the coastline is on the righthand side.

When the distance out has been assessed as enough, the turn is reversed, turning toward the reference (coast) to keep it in sight.

In this reversal, a steep turn should be entered, and as soon as it is obvious that the turn can be completed within the space available, the angle of bank can be reduced if desired.

Starting the reversal with a medium turn is not recommended. If it becomes obvious that a steeper angle of bank will be required, this may not be possible while maintaining altitude.

Constant Radius Turn

The aim of a constant radius turn is to counteract the effects of drift while turning in order to maintain a constant distance from a ground reference.

The purpose of a constant radius turn is to keep a positively identified reference point in sight while waiting for deteriorating weather to improve. It may also be used in a search and rescue or photography context, but not necessarily in the poor-visibility configuration or at low level.

If a constant angle of bank is maintained, the aircraft will gradually drift downwind. To maintain a constant radius around a ground feature, the angle of bank is **constantly** changing.

The initial angle of bank chosen depends on how big the radius is required to be.

It is simplest to describe this manoeuvre by starting directly across the wind at a nominated initial angle of bank, for this example, 15 degrees.

As the aircraft turns to downwind and the groundspeed increases, the angle of bank will need to be **gradually increased**. How much, depends on the strength of the wind. When the wind is directly behind the aircraft, the groundspeed will be maximum and the angle of bank will have reached its maximum, for this example, say 20 degrees.

As the turn continues to crosswind again the groundspeed will gradually decrease and the angle of bank will need to be **gradually reduced**. Until, at exactly across the wind, the angle of bank is the nominated initial angle again, for this example, 15 degrees.

Continuing the turn into wind, the groundspeed will continue to decrease, and the angle of bank will need to be **gradually reduced further**. When the aircraft is directly into wind, the groundspeed will be at its least, and the angle of bank will have reached its minimum, for this example, say 10 degrees.

As the turn continues to crosswind again, the groundspeed will gradually increase. The angle of bank will need to be **gradually increased** until it is at the nominated initial angle of bank, 15 degrees, directly across the wind, and at the starting point.

Airborne Sequence

The airborne sequence is standard, except that medium turns may require no demonstration.

LOW FLYING - CONSOLIDATION

OBJECTIVES:

1. To compensate for inertia, visual illusions and stress when operating the aircraft in close proximity to the ground.
2. To carry out various level turns in the poor-visibility configuration in response to deteriorating weather.

CONSIDERATIONS:

Map Reading

Terrain in profile rather than plan view
Obscured or false horizon
- cross reference instruments

Sloping Terrain

Optical illusion in straight and level
- cross reference instruments

Turbulence

More pronounced at low level
Avoid lee of hills or obstacles
Fly on upwind side of hills or updraught side of valleys

Crossing Obstacles

Cross wires at the pylons
Cross ridges at an oblique angle



AIR EXERCISE:

- 1) **Medium Turn**
 - Slightly increase power to maintain airspeed ___ kts
 - Maximum of 45 degrees AOB
 - Roll in
 - Increase power to maintain airspeed ___ kts
 - Maintain height with backpressure

If airspeed and height cannot be maintained
- Reduce angle of bank/increase power if necessary
Use instrument/visual scan to ensure balanced flight
- Anticipate roll out
- Reduce power to keep airspeed constant
- 3) **Obstacle Avoidance Turn**
 - 180 degree steep turn
- 4) **Coastal Reversal Turn**
 - Assess wind
 - Turn away from coast
 - Sufficient to complete turn
 - **Keep reference in sight**
 - Commence steep turn
 - Reduce AOB as soon as possible

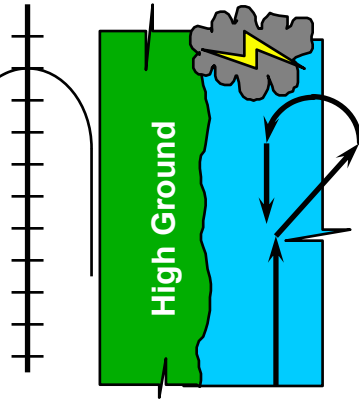

5) **Constant Radius Turn**

- AOB increases & decreases with G/S

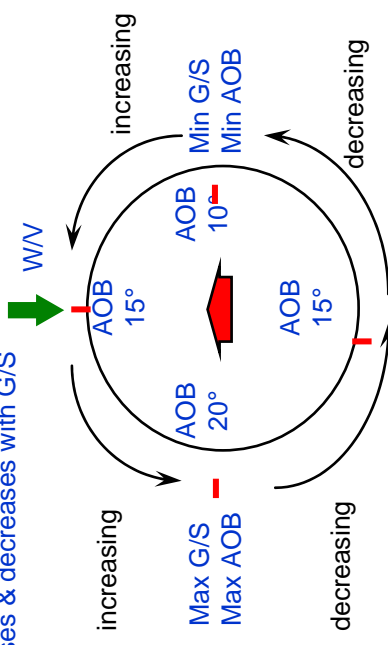

HUMAN FACTORS:

Vision

Illusions caused by drift
Cross reference instruments

Stress

Maintain situational awareness
Avoid need for low flying

AIRCRAFT MANAGEMENT:

LFA Boundaries (OHP)
Min. Height?
Solo?
Over water - Wind > 10 knots
(if applicable)
HASELL
Report entering, duration & leaving LFA
Poor visibility configuration for this A/C
is ___ kts, ___ flap, pwr as required
Frequent **SADIE** checks

Precautionary Landing

This exercise primarily discusses the procedure to follow in the event of being forced to land at other than a recognised aerodrome in conditions of poor visibility.

The reason for carrying out a precautionary landing may not necessarily be poor visibility. However, as this procedure is the one taught and practised, it is recommended that it be adopted for **any** reason a pilot is forced to make an off-aerodrome landing in a serviceable aircraft (refer CFI).

Maintaining situational awareness and pre-flight planning to avoid this eventuality should be stressed throughout the briefing.

Although this exercise assumes the decision to land has been made, the stress associated with making the command decision to actually carry out this procedure should not be underestimated.

Introduction

If, due to a lack of situational awareness and/or poor flight planning, the pilot becomes hopelessly lost, running out of fuel or daylight, or is forced to fly in conditions of poor and deteriorating visibility, she or he may be forced to consider landing anywhere suitable.

Pilots need to learn this procedure, because it may save their lives and the lives of passengers. If for any reason pilots find themselves in this situation, they should accept the mistake – and not make another one by pushing on.

The decision to make a landing off-aerodrome will create considerable stress. However, if making the decision is delayed, there may be little time available to implement the recommended procedure, worsening an already stressful situation.

Avoid this whole situation by careful pre-flight planning and by turning back or diverting early.

Objective

To learn the procedure to adopt in the event of an off-aerodrome landing.

Considerations

The reasons why an off-aerodrome landing may be required are discussed, with emphasis on how to avoid these situations.

Pushing on into deteriorating weather is the most common cause, and it indicates a hazardous attitude. Avoid this situation by setting personal meteorological minima well above the legal minimum. Avoid hazardous thoughts by studying aeronautical decision-making (ADM) principles and learning to apply the appropriate antidote¹⁵⁸.

Getting caught out by deteriorating weather is avoided by careful pre-flight planning, diverting early and avoiding hazardous thoughts, eg, get-home-itis.

¹⁵⁸ refer Simuflight, 1995

Becoming hopelessly lost would not necessarily require the implementation of this procedure, but it is considered here in conjunction with one or more of the other reasons. Becoming lost is avoided by maintaining situational awareness and careful pre-flight planning.

Running out of fuel, which may result from becoming lost or trying to get around weather rather than diverting early, is avoided through careful pre-flight planning and fuel monitoring.

Running out of daylight is avoided by pre-flight planning and the knowledge of the appropriate antidote to hazardous thoughts. Most organisations require all aircraft to be on the ground, or in the circuit, 30 minutes before Evening Civil Twilight (ECT). Apply the traveller's golden rule: start early, finish early.

If any or a combination of the above situations have developed, the recommended procedure is to adopt the poor visibility configuration and carry out an off-aerodrome landing. To execute the **recommended** procedure takes about 15 to 20 minutes, so a timely decision to avoid additional stress is also recommended.

Aircraft Management

No matter how good the landing site chosen, the execution of this procedure for real may result in a landing. Therefore, the appropriate passenger briefing and security checks are carried out.

Make a PAN call and squawk 7700. If the outcome doesn't look favourable you may wish to make a MAYAY call (refer CFI).

As with all low flying, more frequent use of SADIE checks is advised.

The minimum descent altitude (refer CFI) is restated.

Human Factors

The effects (ADVISE mnemonic) of **S**tress and **D**isorientation are the prime considerations in this briefing.

Stress is the prime consideration of this briefing, because of its effect on decision-making, situational awareness, mental workload, problem solving, and arousal/performance.

Minimising stress involves good aviation practice to avoid the situation that calls for this procedure, recognising the hazardous attitudes or thoughts that can lead to it, overlearning the procedure to deal with it, and the application of stress management techniques.

Disorientation, as a result of being lost or flying in reduced visibility, and the effects on vision of precipitation¹⁵⁹ and runway perspective¹⁶⁰ are discussed or revised.

Air Exercise

This exercise is carried out in the low-flying area unless this is over water. The low-flying area pre-entry checks and radio calls are made. If the exercise is to be simulated by maintaining 500 ft agl outside the low-flying area, amend the briefing as required.

¹⁵⁹ Campbell, 1994, p.16

¹⁶⁰ Ewing, 1993, p.52

Descending to 500 ft agl simulates a lowering cloud base and reduced visibility. The poor visibility configuration is adopted, and the decision to land off-aerodrome is simulated.

With the decision made to discontinue the flight, a search for a suitable landing site is initiated, the emergency is declared, and the passengers and cabin secured.

Assessment of the wind is based on the same indicators as the forced landing, except that at low level drift **may** be a valuable indicator.

The selection of a suitable landing site is based on the 6 S's, (the 'E', elevation, is not significant). As power will be used to maintain an estimated height above ground level. If time permits, a suitable landing site with ground assistance nearby can be chosen.

If no obvious landing areas are visible, a turn downwind will give a larger choice of landing sites in the same time.

Once a landing site into wind has been selected for closer inspection, a lefthand low-level (500 ft agl) circuit is established.

In low cloudbase situations, it is recommended that the circuit altitude be established at about 100 ft below the cloud base. This provides both maximum visibility and ground clearance.

Ideally the aircraft is positioned into wind at 500 ft agl with the chosen landing site on the lefthand side, far enough out so that the pilot can look across at the landing site and assess it in relation to the 6 S's.

The position of the sun may be a major factor in the choice of a suitable landing site, especially if the onset of ECT is the reason for landing.

The length of the landing site **may** be assessed through timing (by flying into wind, from fence to fence in the direction of landing). Assuming the airspeed is, for example, 70 kts, then the groundspeed is **about** 70 kts. There are 6080 ft in a nautical mile, therefore the groundspeed is **about** 120 ft per second ($6080 \times 70 \div 3600$). If the basic landing distance is known the landing site can be assessed as suitable or not. If the basic landing distance required is 800 ft, then the minimum flight time, from abeam the threshold to abeam the upwind end, needs to be about 7 seconds.

Convert to metres per second if so desired.

This is an emergency procedure, not a procedure for assessing the suitability of a runway for a normal approach procedure.

On this and subsequent legs, the chosen landing site is assessed in relation to the 6 S's, with particular emphasis on surrounds in the approach and climb-out areas.

Landmarks are chosen (if available) at the beginning and end of each circuit leg to help remain orientated if the pilot loses sight of the landing site.

In addition, on the first upwind leg the heading of the landing direction is generally noted. To reduce mental workload, however, a better method is to align the DI to north while on this leg, regardless of actual heading. Each leg of the required circuit will now have a cardinal heading in nil wind and the landing will always be carried out on a heading of north.

On the downwind leg spacing is assessed using the same airframe reference as a normal circuit. Since the short-field landing technique will be used, the downwind leg is extended – visibility permitting.

At the end of the downwind leg, a ground feature (if available) is selected as a turning point reference.

Assuming the chosen landing site appears suitable up to this point, a second inspection is carried out at a minimum of 200 ft agl.

The base leg is extended through the centre line and the aircraft turned into wind, with the landing site on the lefthand side but closer than during the first inspection. This inspection is to decide exactly which side or part of the landing site will be used for the landing roll. Are there any tree stumps in the long grass?

Established on and parallel to final, a gradual descent to a minimum of 200 ft agl is carried out.

Descent below 200 ft agl is not recommended, because it takes considerable concentration to fly the aircraft level and look at the landing site surface. Also, there is a possibility of unseen obstructions, and since a climb to 500 ft agl will be initiated on completion of this inspection, the climb is minimised.

The major portion of the aircraft inertia will be spent in the first two thirds of the landing roll. Therefore, it is **generally** recommended that the low-level inspection is not prolonged, but a climb to 500 ft agl initiated about two thirds of the way along the landing site (refer CFI).

Climb out in the poor visibility configuration to 500 ft agl. Generally, this climb-out is not treated as a go-around with appropriate configuration changes, because re-establishing the poor visibility configuration on reaching 500 ft agl increases the workload.

The aircraft is re-established on the downwind leg, the passenger briefing is completed, and a short-field approach and landing is carried out.

Considerations

During the landing roll, use maximum braking, avoid major obstacles and above all else, keep the cabin intact.

After landing, the final checklist, as for a forced landing without power, is completed.

Airborne Sequence

The student should be capable of positioning within the low-flying area, checks complete at 500 ft agl, in the poor visibility configuration.

The decision to demonstrate or patter with follow-through depends on your assessment of student ability and whether a descent to 200 ft agl will actually be carried out or simulated (refer CFI).

Although a time constraint may be introduced in later revision exercises, allow the student sufficient time in the introductory lesson to fully complete the recommended inspections.

PRECAUTIONARY LANDING

OBJECTIVE:

To learn a procedure to adopt in the event of an off aerodrome landing becoming necessary.

CONSIDERATIONS:

Situations requiring a precautionary landing

- Bad weather
- Lost
- Low Fuel
- Evening Civil Twilight (E.C.T)

Avoid By

- Met briefing
- Situational awareness
- Divert / return
- ADM
- Route preparation
- Pre-flight planning
- In-flight monitoring
- Land 30 minutes prior

AIRCRAFT MANAGEMENT:

Brief passengers
Security checks

Mayday - 7700

Frequent SADIE checks

Min Alt (refer C.F.I.) 200' AGL

HUMAN FACTORS:

Stress

- Situational awareness
- Command decision making
- Hazards, Risks (Personality)
- Mental workload
- Arousal/performance

Disorientation

- Landing illusions, rain
- Runway perspective's

AIR EXERCISE:

Precautionary Forced Landing (in LFA) descend to 500' AGL.

Adopt Poor Visibility Configuration

- 1) Decision
- 2) Establish wind
- 3) Select field
- 4) Carry out procedure

First Pass

- 500 ' AGL
- Check 6 S's
- Note DI heading
- Extend downwind
- Choose reference points
- Check spacing

Second Pass

- Extend base through centreline
- On final
- Descend to 200 ' AGL
- Detailed surface inspection
- Initiate climb 2/3 field length
- **Climb to 500' AGL**
- Downwind checks
- Brief passengers
- Make short-field approach

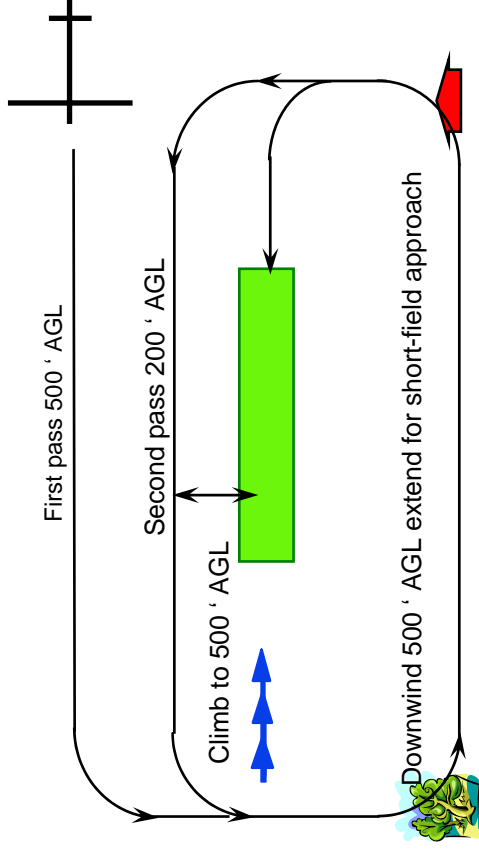

CONSIDERATIONS:

Use maximum braking, avoid major obstacles
Keep the cabin intact
After landing checks

Instrument Flying – Introduction

Instrument flying is a huge subject that cannot be adequately covered in the three pre-flight briefings given here. In practice you will need to develop briefings to adequately cover the syllabus (with the assistance of your supervisor) for use throughout the 5 hours of instrument flight training.

The five-hour course of instrument flight instruction given to student pilots is purely a survival technique for an event that should never occur – inadvertent flight into cloud. It should be emphasised throughout training that this course of instrument flight instruction does not permit or prepare the student for flight into cloud.

In addition, emphasis should be placed on full panel instrument flight – rather than limited panel – for the following reasons:

- Not only are modern aircraft instruments reasonably reliable, but also flight using limited panel (and the recovery from unusual attitudes, full panel) is training for the possibility of an emergency within an emergency that average aircraft management could have avoided.
- Rushing onto limited panel training generally results in a student who can control the aircraft on limited panel, but who bounces off the limits in heading and altitude holding on full panel – a ridiculous situation. This behaviour indicates poor training in the use and interpretation of the control and master instruments, as well as poor scanning technique.

Introduction

Inadvertent flight into cloud can be avoided through situational awareness. However, a five-hour course of instrument flying is included in the requirements for PPL issue, to give the pilot and passengers some chance of survival should the event occur.

Like all emergency procedures, instrument flight is simulated under carefully controlled conditions to ensure adequate safety.

Describe the method of simulation, for example, hood or glasses.

Flight in cloud is dangerous because, when we are deprived of visual references, the body's other senses may provide conflicting information to the brain¹⁶¹. Without the benefit of vision to resolve these conflicts, loss of aircraft control can occur very quickly, usually within one minute¹⁶².

However, instrument flying has a practical application to visual flying when the normal cues are missing or misleading; for example, night flying, mountain flying, low flying or flying over water with a poor horizon.

Instrument flight is challenging because of the need to interpret and anticipate the instrument readings while recognising or ignoring the conflicting messages sent to the brain by our earthbound orientated senses.

Objectives

1. To experience the sensory illusions that occur when deprived of visual references.

¹⁶¹ New Zealand Flight Safety, 1995

¹⁶² New Zealand Flight Safety, 1988

2. To maintain straight-and-level flight by sole reference to the aircraft instruments.

Additional full-panel instrument flight briefings will be needed to discuss climbing, descending, normal turns and the recoveries from the power-on spiral dive and stall onset in the climbing turn.

When instrument flying normal turns are rate one. Medium turns using 30 degrees angle of bank are currently a requirement of the CPL syllabus only.

Unusual attitude recoveries (limited panel) are not currently a requirement of the PPL syllabus.

Refer to Civil Aviation Rules and Advisory Circulars for the current syllabus requirements of each licence type.

Considerations

The direct and indirect information that each of the flight and engine instruments give, as well as their power source, are discussed¹⁶³.

The formula Power + Attitude = Performance remains unchanged for instrument flight, therefore, there are two types of instruments. One type are the **control instruments**, which are the tachometer (rpm/power – for most training aircraft) and the attitude indicator (pitch and bank attitude). The other flight instruments are **performance instruments**, which indicate the resultant performance of the power + attitude combination.

Control Instruments

Tachometer

The tachometer directly indicates the engine rpm and indirectly the engine power output. In addition, rpm may indirectly indicate pitch attitude (rpm increasing, nose low; rpm decreasing, nose high).

The tachometer is commonly driven from the engine by a mechanical cable.

Attitude Indicator or Artificial Horizon

The Attitude Indicator (AI) or Artificial Horizon (AH) is the **master** instrument, because it presents pitch and bank attitude information directly (in miniature) against an artificial horizon.

Miniaturisation of the outside world means that small movements indicated on the attitude indicator represent quite noticeable changes in pitch and bank. Therefore, it is common to speak of pitch attitude changes in relation to the **width** of the wing bars representing the aircraft within the AI. For example, the straight-and-level attitude is half a wing bar width above the horizon.

Indirectly, the attitude indicator is a guide to airspeed (nose low, high or increasing airspeed; nose high, low or decreasing airspeed).

The attitude indicator is most commonly driven by an engine-driven vacuum pump.

Performance Instruments

Airspeed Indicator

This gives the aircraft speed directly and, indirectly, pitch attitude (airspeed increasing, nose low; airspeed decreasing, nose high). Its source of power is the pitot-static system.

¹⁶³ refer Campbell, 1994

Altimeter

The altimeter directly indicates the height of the aircraft above a datum, usually sea level. Indirectly, it indicates pitch attitude (altitude decreasing, nose low; altitude increasing, nose high). Its source of power is the static vent.

Heading Indicator

The heading indicator is known as Directional Indicator (DI), or Directional Gyro (DG), or Horizontal Situation Indicator (HSI). The DI directly indicates the aircraft heading, **when aligned with the magnetic compass**. Indirectly, it can indicate bank. Heading indicators are commonly driven by the engine-driven vacuum pump.

Turn Coordinator

The Turn Coordinator (or Turn Indicator) directly indicates the rate of change of direction. Indirectly, it can indicate limited angles of bank (**provided** balance is maintained), commonly up to about 35 degrees. Any further increase in bank angle will not be indicated by the turn coordinator. Turn coordinators are normally electrically driven.

Balance Indicator

This Balance Indicator is commonly incorporated within the turn coordinator and directly indicates balance. Indirectly, it indicates yaw if the wings are level, or bank. Its power source is gravity, or the resultant of in-flight accelerations (CPF, CFF).

Vertical Speed Indicator

The Vertical Speed Indicator (VSI) directly indicates the rate of change of altitude. Indirectly, it indicates pitch attitude, and it is most useful when used as a trend indicator, as it will indicate a tendency to change altitude long before the altimeter registers any change. Its power source is the static system.

Instrument Layout

The four instruments, Attitude Indicator, Airspeed Indicator, Altimeter, and Heading Indicator, are arranged on the instrument panel in a Basic T shape¹⁶⁴.

The addition of the Turn Coordinator/Balance Indicator, and the Vertical Speed Indicator instruments to the basic T make up the full instrument flying panel.

You may prefer to group the instruments by power source rather than instrument panel layout (refer CFI).

Aircraft Management

The requirement for, and qualifications of, a safety pilot for simulated instrument flight practice are explained (student pilots, dual only).

It is recommended when the safety pilot gives an instruction, for example, to turn left, that the safety pilot should follow with “clear left”. In addition, if the safety pilot fails to verbalise that it is clear to enter the turn, the student should query the instruction, for example, “clear left?”

If evasive action is required, the safety pilot should use the phrase “I have control” and the pilot simulating instrument conditions should immediately relinquish control. The responsibilities of the safety pilot should be briefed by the pilot-in-command before flight.

The aircraft vacuum and pitot-static systems should be described (OHP or handout recommended).

¹⁶⁴ Trollip & Jensen, 1991

The method of setting the attitude indicator's aircraft symbol before flight, and the desirability of not altering it in flight, are explained.

The importance of checking instruments while taxiing and in-flight SADIE checks are revised.

Human Factors

The effects (ADVISE mnemonic) of **D**isorientation, **V**ision, **I**nformation processing and **S**tress are the prime considerations in this briefing.

The limitations of the visual, vestibular and seat-of-the-pants type senses are the prime considerations of this briefing and should be supported with OHP and handout material.

Humans use three sensing systems to gather and transmit information to the brain in order to remain orientated. These are the balance organs within the vestibular system of the inner ear, the muscular pressure sensors of the nervous system, and vision – the most powerful system of the three.

The balance organs of the vestibular system sense angular acceleration or change of direction in three different planes by the detection of fluid movement in the semicircular canals. In addition, the otolith organ senses linear acceleration as well as head or body forward or aft tilt, through the movement of a jelly-like mass over sensitive hairs.

This system is limited by the inability to detect change when the direction or the angular acceleration is constant or very slow. It can also misrepresent acceleration as a nose pitch up, because of the effect of inertia.

The muscular pressure sensors of the nervous system are affected by gravity and allow us to detect, for example, whether we are standing or sitting when our eyes are closed.

The limitation of this system is that it cannot differentiate between the various causes of increased G, for example, as the result of pulling out of a dive or of entering a steep turn.

The visual system is the most powerful of the orientation systems and normally resolves any ambiguous or conflicting information received by the brain, for example, this is a steep turn not a dive pull-out.

In instrument flight conditions the visual references used to resolve ambiguous or conflicting orientation information are not available. Until considerable practice has been carried out to replace the normal visual cues with instrument readings, orientation conflicts may occur, causing various illusions, for example, *the leans*.

Because the limitations of the human orientation system are considerable, and instrument failure is rare, **trust the instruments**.

Stress, as a result of inadvertent flight into cloud, will be increased and can be expected to affect performance. This usually results in a narrowing of attention and a tendency to fixate on one or a limited number of instruments¹⁶⁵. Stress is best controlled by maintaining situational awareness and by timely decision-making to avoid the need for this emergency procedure.

¹⁶⁵ refer 'arousal and narrowing of attention', O'Hare & Roscoe, 1992, p.159

Air Exercise

The air exercise starts with an appreciation of the limitations of the vestibular and muscular systems.

Selective radial scanning is introduced. Selective radial scanning recognises that the attitude indicator is the master instrument and therefore employs an instrument scanning pattern that radiates out from, and always returns to, the attitude indicator.

The relative importance of the performance instruments varies – and therefore the scan rate varies – with the manoeuvre being executed. This is described in relation to maintaining straight-and-level as well as achieving straight-and-level from the climb and descent¹⁶⁶.

Although Campbell recommends **PAT** for entry to the climb on instruments, the transition from normal cruise to the climb on instruments may be more smoothly executed by selecting attitude first and, as the airspeed decreases, increasing power (APT). At this level of training the student should be aware that the climb entry sequence may be varied, depending on whether the airspeed is above or below the climb speed (refer CFI).

Climbing, descending and turning at rate 1 follow a pre-flight briefing sequence and content similar to the visual exercises, replacing visual cues with instrument indications.

During visual flight training the requirement to counteract inertia (change-check-hold) will have become automatic as a result of cues detected by peripheral vision. These cues will no longer be available and the necessity to consciously counteract inertia through this process when changing attitude will need to be emphasised during early instrument lessons¹⁶⁷.

Airborne Sequence

It is important to demonstrate the limitations of the body's physiological orientation systems carefully. The instructions below should be followed exactly so that the student **does** experience the false sensations of turning and pitching. An unconvincing demonstration may lead the student to believe they are immune to false indications. There are many demonstrations that show the susceptibility of the human senses to disorientation; it should only be necessary to show a few of them.

The False Sensation of Turning

In straight-and-level flight, ask the student to close their eyes and lower their head, remind them to resist any temptation to look out, if they do they will not feel what is normally sensed during instrument flight.

Lower the right wing very gently and then positively roll the wings level while raising the nose attitude without changing power. At this stage ask the student what attitude the aircraft is in. Their balance and postural sensations will normally lead them to conclude that the aircraft has entered a turn to the left.

The False Sensation of Climbing

In straight-and-level flight, ask the student to close their eyes and lower their head. Enter a medium turn to the left using a positive entry, then very gently change to a turn to the right while applying consistent backpressure to the control column. Ask the student to tell you what attitude they think the aircraft is in. The sensation they have felt will be that the aircraft is in a climbing left turn.

Once the student has seen that the sensation received from the senses of balance and posture can be misleading, they will have a better appreciation of the need to be able to fly by

¹⁶⁶ refer Campbell, 1994

¹⁶⁷ refer Campbell, 1994, p.19-25

instrument reference before attempting to enter cloud or any other condition where outside visual references are minimal or completely absent.

It is not necessary to handle the aircraft violently or adopt extremes of attitude to achieve the effects of disorientation.

The student should be advised that, although they were deprived of vision during these manoeuvres, the inexperience of the student in replacing outside visual references with instrument indications may produce the same conflict between the senses, leading to disorientation.

During transitions from the climb or descent to straight-and-level it will be necessary to slow the students actions down to consciously follow the change-check-hold-adjust-trim sequence.

The handout for this lesson should include the limitations of the human balance system, as well as a range of articles on incidents and accidents resulting from attempting continued VFR flight into deteriorating weather¹⁶⁸.

¹⁶⁸ refer various Flight Safety publications

INSTRUMENT FLYING - INTRODUCTION

OBJECTIVES:

1. To experience sensory illusions as a result of being deprived of visual references.
2. To maintain straight and level flight by sole reference to the aircraft instruments.

Power + Attitude = Performance

CONSIDERATIONS:

RPM AI ASI, ALT, DI, TC, VSI

BASIC 'T'

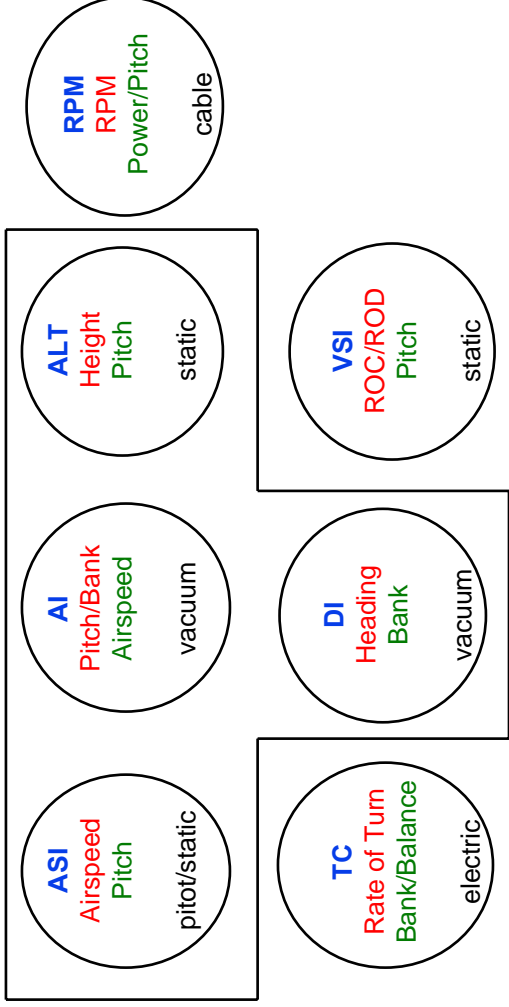

Direct information (red) Indirect information (green) Source (black)

AIRCRAFT MANAGEMENT:

Safety Pilot - Min PPL

- Type rated

Briefing - Calls:-

"Clear Left or Right"

"I have control" (if evasive action required)

Vacuum system

Pitot/Static system

Set AI bar

Taxi & SADIE checks

HUMAN FACTORS:

Vestibular - Sensory organs in the inner ear detect angular acceleration

- linear acceleration, head tilt.

Muscular - Nerve receptor system

(Skin pressure, muscle, limb position).

Visual - Horizon and familiar ref points must be replaced with instruments.

Orientation conflicts may occur

Trust instruments!

Stress - Performance vs Arousal

AIR EXERCISE:

- 1) Appreciate the unreliability of vestibular and muscular senses without visual reference.
- 2) Selective Radial Scan (SRS). **AI - Master Instrument**

Entering S&L - Select attitude (approximately) and power.

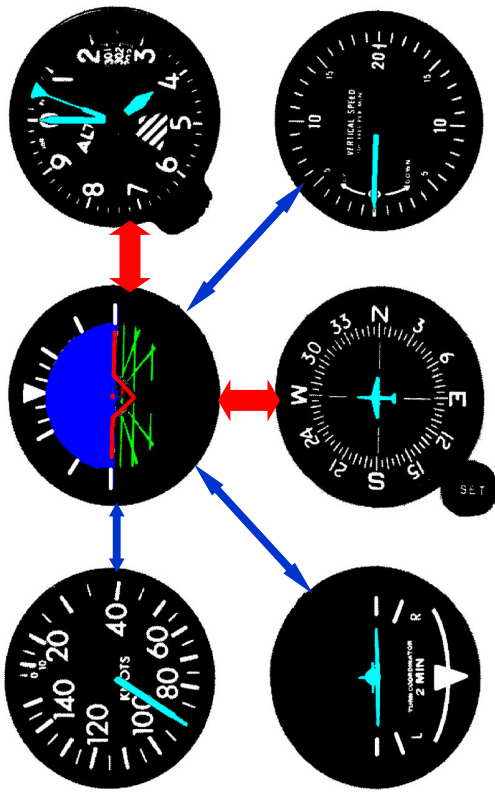

S & L (Maintaining)

Primary

Secondary

Don't fixate on instruments
- Keep scan going

All turns are Rate One

When making changes

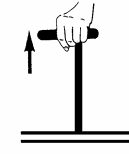

Change

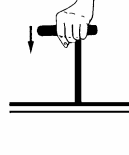

Check

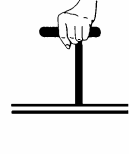

Hold

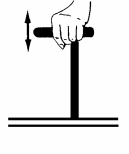

Adjust



Trim

Trust Your Instruments

Instrument Flying – Limited Panel

When any one or more of the basic six flight instruments fails, or is unserviceable, the instrument panel is **limited**.

Failure of the master instrument, the Attitude Indicator (AI), is the most serious and, therefore, the most commonly simulated. However, failure of the other instruments and most importantly, recognition and early detection of failure, should be discussed.

Limited-panel instrument flight at the PPL level requires only the ability to fly straight-and-level and carry out level rate one turns onto compass headings (sufficient to reverse course and fly out of cloud). Additional briefings will be required to adequately cover the requirements of limited-panel instrument flight for CPL students.

Introduction

This exercise simulates the failure of one or more flight instruments, before or after inadvertently entering cloud. In this situation indirect readings of the other flight instruments are used to fill in the gaps as a result of losing the direct information from the failed instruments.

Limited-panel instrument flight still employs the selective radial scan technique, which recognises the changing importance of various instruments with the phase of flight.

Objectives

1. To maintain straight-and-level flight by sole reference to a limited flight instrument panel.
2. To carry out rate one level turns onto compass headings.

Considerations

Various power source failures and their effects on the flight instruments are discussed, from the least serious to the most serious.

Although the tachometer is not a flight instrument, its possible failure should be briefly discussed. Rpm can be estimated from sound and, since only the gauge is unserviceable, power is still available to be used as required.

Turn Coordinator (or Turn Indicator)

Turn coordinators are normally electrically driven. If power is not being supplied to the turn coordinator, a warning flag is displayed. The turn coordinator is checked for serviceability during taxiing and the electrical system during SADIE checks. Its failure would mean that the rate of turn would have to be estimated through angle of bank (about 15 degrees for rate one, up to 100 kts). The balance indicator is unaffected.

Vertical Speed Indicator, Altimeter

Both VSI and altimeter rely directly on outside air pressure sensed at the static vent. If the static vent becomes blocked, neither the VSI nor the altimeter will indicate correctly.

The static vent is inspected for blockages during the pre-flight inspection.

Failure of the VSI and altimeter would require use of the control instruments (AI and tachometer) to achieve the desired performance. For example, attitude for 70 kts plus power about 1500 rpm, equals rate of descent about 500 ft/min.

Airspeed Indicator

The airspeed indicator's source of power is a combination of the static and pitot system. If the static vent is blocked, airspeed will decrease in the climb and increase in the descent. If the pitot system is blocked (most commonly by ice), airspeed will decrease in the descent and increase in the climb or, depending on the type of pitot/static system, airspeed may simply reduce to zero in level flight.

The pitot tube is inspected for blockages during the pre-flight inspection.

Failure of the ASI requires use of the control instruments (AI and tachometer) to achieve the desired performance.

Heading Indicator

The heading indicator is variously known as the Directional Indicator (DI), or Directional Gyro (DG), or Horizontal Situation Indicator (HSI). Heading indicators are gyro-stabilised and are commonly driven by the engine-driven vacuum pump. If the vacuum pump fails the gyro will gradually run down, losing rigidity, and the DI will become unusable.

The DI and vacuum system are checked for serviceability before flight during taxiing and the engine run-up, and in-flight, through SADIE checks.

Failure of the DI requires direct use of the magnetic compass for heading information.

Attitude Indicator

The Attitude Indicator (AI), also known as the Artificial Horizon (AH), is most commonly driven by an engine-driven vacuum pump.

AI serviceability is checked during taxiing and in flight through SADIE checks.

Failure of the AI will require use of the indirect information available from the performance instruments to establish the aircraft attitude.

Aircraft Management

Revise the desirability of briefing the safety pilot on their duties and responsibilities.

Revise knowledge of the aircraft systems in the event of a malfunction.

The turn coordinator and electrical system are protected by circuit breakers (CB). Electrical failure may affect other instruments, for example, fuel gauges.

The static system is commonly backed up by an alternate static source, the location and operation of which should be described.

The pitot head is commonly heated to prevent ice build up.

The serviceability of the vacuum system is confirmed through regular reference to the vacuum gauge.

Revise the importance of checking instruments while taxiing and in-flight SADIE checks.

Human Factors

The effects (ADVISE mnemonic) of **V**ision, **I**nformation processing and **S**tress are the prime considerations in this briefing.

Developing a systematic instrument scan to maintain situational awareness is the prime consideration of this briefing.

Because the limitations of the human orientation system are considerable, and instrument failure is rare, **trust the instruments**.

The effect of unreliable information on information processing should be discussed. The pilot should not have access to unreliable information that could be used in any way¹⁶⁹. It is recommended that unreliable information, for example, instruments that have failed, are removed from the pilot's scan. This is very difficult to do mentally, and covering the instrument is therefore usually recommended.

Stress results in a narrowing of attention and a tendency to fixate on one or a limited number of instruments. The effects of stress are reduced through regular practice and are negated by avoiding the situation.

Air Exercise

Failure of the vacuum system is assumed, and the indirect information available from each instrument to maintain control in each plane is revised.

- **Pitch** – Determined from airspeed, altimeter, vertical speed indicator and rpm (noise).
- **Bank** – Determined from turn coordinator when balanced (ball), and compass.
- **Yaw** – Determined from balance (ball).

The selective radial scan (SRS) technique is described in relation to maintaining straight-and-level and completing rate one turns onto compass headings without the master instrument.

For straight-and-level, the altimeter and turn coordinator are incorporated in the primary scan with VSI and compass included in the secondary scan. Airspeed requires little attention since the attitude + power combination will provide the desired performance.

For level rate one turns onto compass headings, the altimeter and turn coordinator remain in the primary scan, with the importance of the compass gradually increasing as the required roll out heading is approached. Once again, airspeed requires little attention.

Airborne Sequence

The airborne sequence commonly starts from straight-and-level on full panel. A vacuum failure is simulated and therefore the AI and DI are unserviceable. These instruments are capable of providing unreliable information that could be used, so they are removed from the scan by fitting them with instrument covers.

Straight-and-level is maintained on limited panel and rate one turns practised, eventually onto compass headings.

All instrument flight requires considerable concentration, therefore, do not keep the student at the exercise for long periods – little and often is best.

¹⁶⁹ Wickens & Flach, 1988

INSTRUMENT FLYING - LIMITED PANEL

OBJECTIVES:

1. To maintain straight and level flight by sole reference to a limited flight instrument panel.
2. To carry out rate one level turns onto compass headings.

CONSIDERATIONS:

Power source failures

- Pitot/Static
 - Altimeter
 - VSI
 - Airspeed
- Suction
 - Attitude Indicator
 - Direction Indicator
- Electrical
 - Turn Coordinator
- Cable
 - RPM

AIRCRAFT MANAGEMENT:

Safety Pilot Briefing

Turn Coordinator } CB's
Electrical }

Pitot/Static - Pitot Heat
- Alternate

Suction - Vacuum gauge

Taxi & SADIE checks

HUMAN FACTORS:

Trust Instruments!!

- Orientation conflicts may occur
- Remove unreliable information from the scan
- use instrument covers
- Stress**
- Performance vs arousal
- Don't fixate on instruments
- Keep the scan going
- Avoid inadvertent flight into cloud!**

AIR EXERCISE:

1) Vacuum System Failure.

PITCH	ASI, VSI, ALT & RPM
BANK	Turn Coordinator (balanced) & Compass
YAW	Ball

2) Selective Radial Scan (SRS)

Maintain S&L

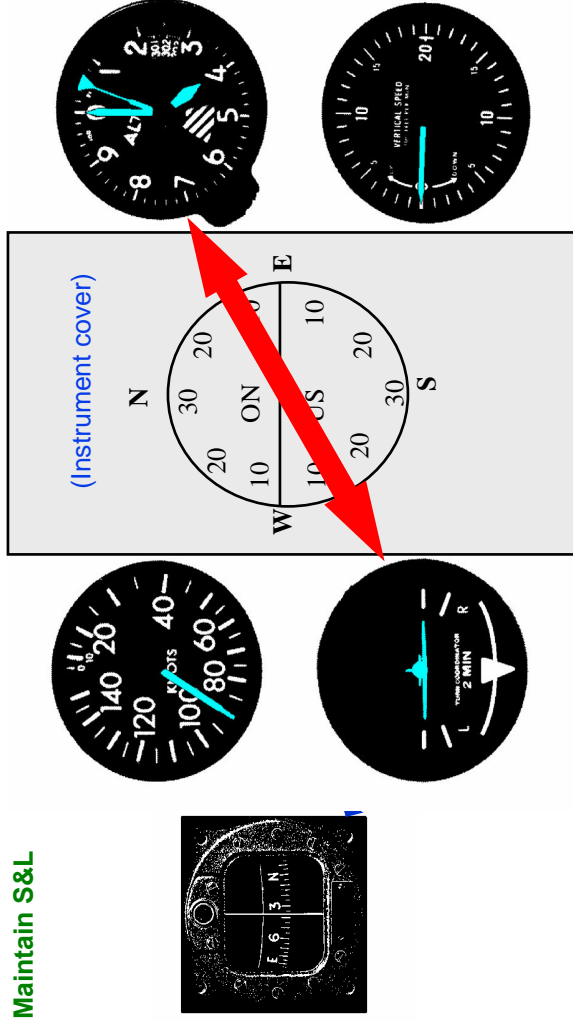

Primary

Secondary

3) Level Turns (all turns are rate one) onto Compass Headings.

NOTE: When making changes

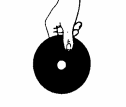
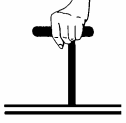
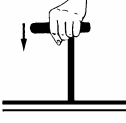
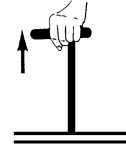

Change

Check

Hold

Adjust

Trim

Instrument Flying – Unusual Attitudes

The recovery from unusual attitudes is divided into full- and limited-panel recoveries. Full-panel recoveries are a requirement of the PPL syllabus, and limited-panel recoveries are a requirement of the CPL syllabus.

During full-panel recoveries the AI remains the master instrument. During limited-panel recoveries the indirect information of the performance instruments must be used to assess the aircraft attitude and achieve recovery to straight-and-level flight.

This briefing discusses the requirements of recovery using a limited panel and should be modified for the student's requirements (refer CFI).

Introduction

The briefing deals with the recovery of the aircraft, to straight-and-level, once an unusual attitude has been identified. An unusual attitude could be described as any performance that does not equal the power + attitude combination.

Basically there are two types of unusual attitude, nose-high or nose-low. The most dangerous of the nose-low attitudes is the spiral dive, because it is difficult to identify.

The spiral dive produces positive G, which feels like a dive pull-out when, in fact, the aircraft is being pulled tighter into the spiral dive.

Unusual attitudes may come about as a result of disorientation, turbulence (which may be quite pronounced in cloud) or a distraction that breaks down the instrument scan.

In addition, the effects of stress on arousal will affect performance and may result in fixation on one instrument, or on a minor aspect of performance or problem. At the same time, inadvertent flight into cloud, full- or limited-panel, can be expected to be a very stressful experience.

Therefore, **avoid the situation entirely.**

Objective

To recognise, and recover to straight-and-level from, a nose-high or nose-low unusual attitude.

Considerations

The first step to recognition of an unusual attitude is to maintain faith in the instrument indications. This can be difficult when your body senses are screaming at you that the instruments must be wrong!

The reasons for loss of control are discussed. A distraction, fixation or workload may cause an interruption to the scan. Disorientation may occur as a result of the leans while night flying or in poor visibility.

The unusual attitude recovery is always carried out to regain straight-and-level. **Then** a gradual return to the references (altitude and heading) is made. No attempt to return direct to the references should be made, as this may increase disorientation or lead to another unusual attitude.

Recovery from unusual attitudes uses the same change-check-hold-adjust-trim sequence as all flight. However, the initial movements are more pronounced, and trim should not be required.

To regain straight-and-level, the position of the horizon must be identified. There are several methods of achieving this (refer CFI).

The method recommended here is to use the altimeter.

If the altitude is increasing, the initial change will require a decrease in backpressure (push). If the altitude is decreasing, the initial change will require an increase in backpressure (pull). As soon as the hundreds pointer **stops** moving, the aircraft is in the level attitude, so, check-hold-adjust (trim should not be required).

Aircraft Management

Revise briefing the safety pilot on their duties and responsibilities.

Ensure adequate height for recovery.

Revise limiting speeds (V_A , V_{NO} , V_{NE}) and rpm limit.

Human Factors

The effects (ADVISE mnemonic) of **D**isorientation, **V**ision and **S**tress are the prime considerations in this briefing.

Revise systematic instrument scanning to maintain situational awareness.

The limitations of the human orientation system are considerable, and instrument failure is rare; if disorientation occurs, trust the instruments.

Stress results in a narrowing of attention and a tendency to fixate on one or a limited number of instruments. The effects of stress are reduced through regular practice and are negated by avoiding the situation.

Air Exercise

The air exercise details the recognition and recovery from the nose-high, nose-low and spiral-dive unusual attitudes.

Nose-high recognition – low or decreasing airspeed, increasing altitude, increasing rate of climb, and decreasing engine rpm.

Nose-high recovery – full power and simultaneously level the wings (check balance), push forward on control column until the altimeter stops, check, hold, at normal cruise airspeed reduce power to cruise and adjust (trim if required).

Nose-low recognition – high or increasing airspeed, decreasing altitude, increasing rate of descent, and increasing rpm.

Nose-low recovery – reduce power (how much depends on rate of airspeed increase) and simultaneously level the wings (check balance), ease out of the dive, when altimeter stops, check, set cruise power, hold and adjust (trim if required).

Spiral-dive recognition – high or increasing airspeed, decreasing altitude, high angle of bank (usually turn coordinator on stops), high rate of descent, high or increasing G-loads, and increasing rpm.

Spiral-dive recovery – throttle closed, then the same procedure as for nose-low unusual attitude recovery (smooth control movements above V_A).

Once straight-and-level flight has been regained, return to the original references (heading and altitude).

Airborne Sequence

Ensure a safe altitude, and avoid extreme attitudes.

INSTRUMENT FLYING - UNUSUAL ATTITUDES

OBJECTIVE:

To recognise and recover to straight-and-level from a nose-high or nose-low unusual attitude.

CONSIDERATIONS:

Trust Your Instruments

Reasons for loss of control

Interrupted instrument scan	Disorientation
Distraction Fixation Cockpit workload	Leans Night flying Poor visibility

Recover to Straight and Level

Identifying the horizon (limited panel only)



Change - pull (nose low) or push (nose high)
 Until the altimeter's "big hand" stops
Check
Hold
Adjust
Trim (should not be required)

AIR EXERCISE:

Unusual Attitude	Recognition
Nose High	Low & decreasing airspeed - Increasing altitude ROC - Decreasing RPM
Nose Low	High & increasing airspeed - Decreasing altitude ROD - Increasing RPM
Spiral Dive	High & increasing airspeed - Decreasing altitude High rate of turn High & increasing 'G' - High ROD - Increasing RPM

Recovery

Nose High

- Full power
- Level wings
- Change - push to horizon
- Check
- Hold
- At normal cruise speed
- Set cruise power
- Adjust
- Trim (if required)

Nose Low

- Reduce power
- Level wings
- Change - pull to horizon
- Check
- Set cruise power
- Hold
- Adjust
- Trim (if required)

Spiral Dive

- Close throttle
- Level wings
- Change - ease out of the dive
- Check at horizon
- Set cruise power
- Hold
- Adjust
- Trim (if required)

AIRCRAFT MANAGEMENT:

Safety Pilot - Min PPL

- Type rated
- Briefing - Calls:-
- "Clear Left or Right"
- "I have control" (if evasive action required)

Limiting speeds

Va Vno Vne

Limiting RPM

HUMAN FACTORS:

Situational Awareness

- through systematic scan
- Disorientation**
- orientation conflicts may occur
- trust instruments!!

Stress

- performance vs arousal
- fixation
- avoid situation entirely

Map-Reading

This map-reading briefing is an **introduction** to **basic** navigation techniques and the elementary navigation exercises. This exercise does not meet the requirements of the PPL cross-country navigation syllabus.

Commonly this exercise is carried out within the training area, and certainly within 25 miles of the departure aerodrome. It is not a cross-country flight, and does not necessarily require the student to have attained a pass in any written subjects before its introduction.

Cross-country exercises, to meet the requirements of the cross-country navigation syllabus, will require individual briefings for each exercise to be developed with the aid of your supervisor. Most training organisations have established routes and guidance material for instructors on what aspects to cover in each exercise to meet the requirements of the cross-country navigation syllabus (refer CFI).

Introduction

Map-reading is a basic skill of navigation. Therefore, you need to be able to read and use aeronautical charts before moving on to true navigation.

Objective

To read, prepare and use aeronautical charts as an aid to navigation.

Considerations

The basics of map-reading, preparation and use are discussed. A suitable chart is selected, the 1:500,000 series (Sheets 1 to 4). The following are noted:

- **Contours and layer tinting.** The height of terrain above sea level is depicted by contours and layer tinting.
- **Spot heights and obstructions.** These are given as heights above sea level, with the highest point within a grid given as thousands and hundreds, for example, 28 means 2800 ft amsl.
- **Water features.** These are coloured blue, and the distinctive shapes of lakes make them excellent features for determining a **fix**.
- **Cultural features.** These include roads, railways, powerlines, dams, lighthouses and aerodromes.
- **Built-up or forestry areas.** These form shapes and relationships with other built-up areas and cultural features.

Line features are used in map-reading to confirm track made good (left or right). These are railway lines, major roads, powerlines, rivers and coastlines. When flying parallel to them, they are of no use on their own in determining distance flown.

Line features may also be used to determine time or distance flown, when they are crossed at right angles. They are used to confirm the aircraft groundspeed and ETA. If the aircraft track crosses a line feature at right angles, the exact distance from departure or the last fix, and the time taken is known; from these the groundspeed and time to destination can be calculated.

Crossing line features at right angles, however, gives no indication of track made good (left or right).

Funnel features (when available) are used to ensure that a position cannot be missed. Usually they comprise two line features that gradually converge toward the destination.

A **fix** is established when the aircraft position is positively identified and the time recorded.

A **dead reckoning** (DR) position is established when a constant heading (allowing for drift) has been maintained for a known time at an estimated groundspeed. From this the aircraft position can be estimated. This is surprisingly accurate – if a constant heading is maintained.

Chart preparation for this exercise involves folding the chart for easy cockpit reference. Chart use involves reading from the map to the ground.

Aircraft Management

Discuss cockpit management in relation to preparation and accessibility of the chart, pencil, VFG and terminal chart. The use of a kneeboard or clipboard is recommended. Pencils should be securely attached by Velcro strips or string to the clipboard and should not be too sharp.

Aspects of crew resource management (CRM) are introduced or revised, in relation to the assistance of passengers or crew to hold documents, look up information, and keep a lookout for other aircraft.

Mixture leaning is introduced or revised (refer CFI).

Revise fuel management, SADIE and compass checks.

Human Factors

The effects (ADVISE mnemonic) of **V**ision, **I**nformation processing and **S**tress are the prime considerations in this briefing.

The effect of cockpit workload on stress, and the detrimental effects of stress on information processing, mindsets, decision-making and performance, are revised. They are minimised through careful pre-flight planning.

For a comprehensive list of human factor aspects to be discussed throughout cross-country navigation training, refer to 'Conclusions on briefings and lessons' in the RNZAC Instructor Council's 'Safe Human Flight Training Seminar' (1994).

Air Exercise

The air exercise will vary between organisations, but primarily it deals with comparing those features available with the chart, and their visual aspects as seen from cruise altitude.

Although preparation of a flight log is not part of this exercise, timing between two fixes may be recorded so that the method of calculating groundspeed and revised ETA may be discussed during the debrief.

Airborne Sequence

Where possible, the exercise is carried out at typical cross-country cruise altitudes.

MAP- READING

OBJECTIVE:

To read, prepare and use aeronautical charts as an aid to navigation.

CONSIDERATIONS:

Select an appropriate chart

Contours and layer tinting
 Spot heights and obstructions (AMSL)
 Water features - lakes, rivers, coastline
 Cultural features - road, railway, dam, lighthouse, aerodrome
 Built up or forestry areas - shape

Line features
 confirm track made good

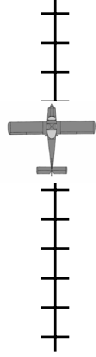

OR
Time/distance
 confirm G/S and ETA

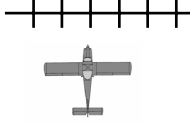

Ground features
 confirm position

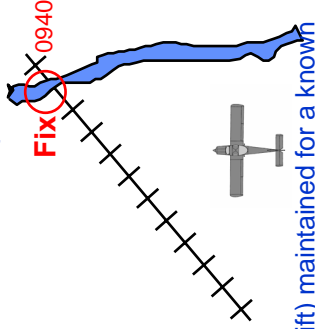

Fix - a positively identified position and time

DR position - estimated from constant heading (allowing for drift) maintained for a known time at an estimated groundspeed

Chart preparation - fold the chart for easy cockpit reference

Chart use - read from the map to the ground

AIR EXERCISE:

1. Choose chart
 2. Draw route
 3. Prepare chart
- as appropriate to your organisation
4. Fly the route reading from map to ground
 5. Compare map symbols with ground features
 6. Note time between two positions for later G/S calculations

AIRCRAFT MANAGEMENT:

CRM: Attach pencil to keyboard or clipboard. Have spares
 Use pax to hold or find info and assist with lookout.
 Lean mixture
 Fuel management
 Compass & **SADIE** checks

HUMAN FACTORS:

Stress - Performance vs Arousal
 - Cockpit workload
 - Mindset
 Affects - **Information processing**
 - **Decision making**
Careful pre-flight planning is essential

APPENDIX A

Approach Perspectives

**OHP USE
RECOMMENDED**

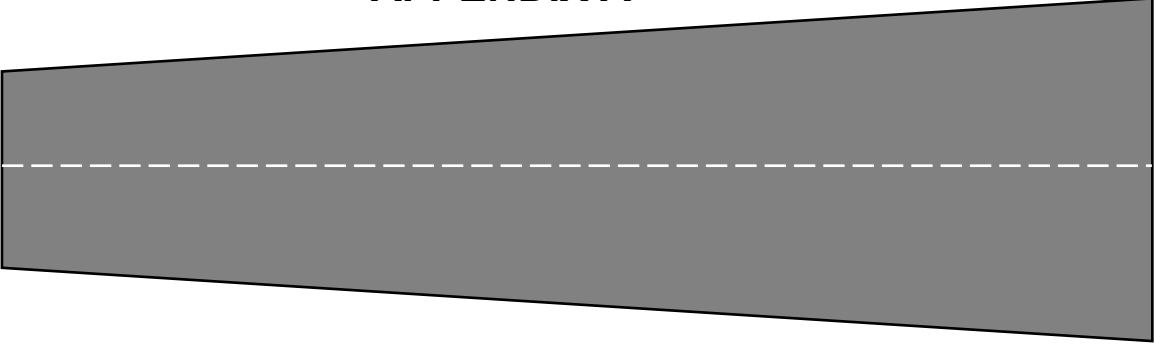

HIGH

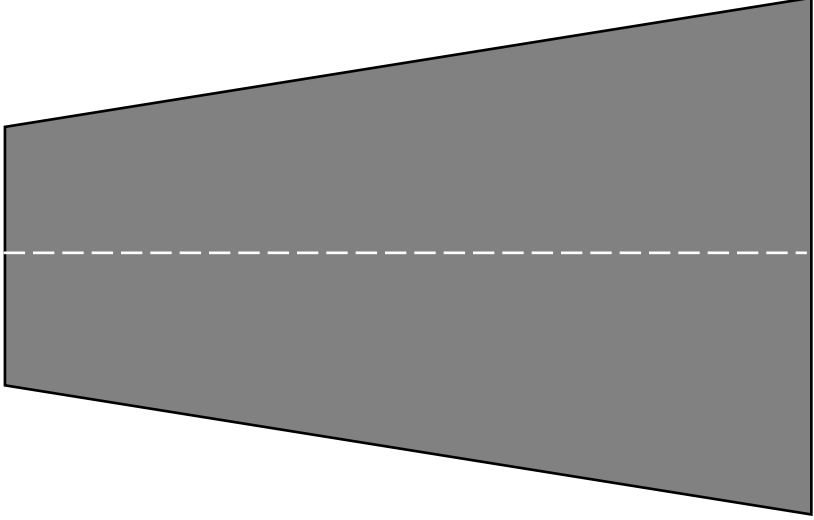

CORRECT

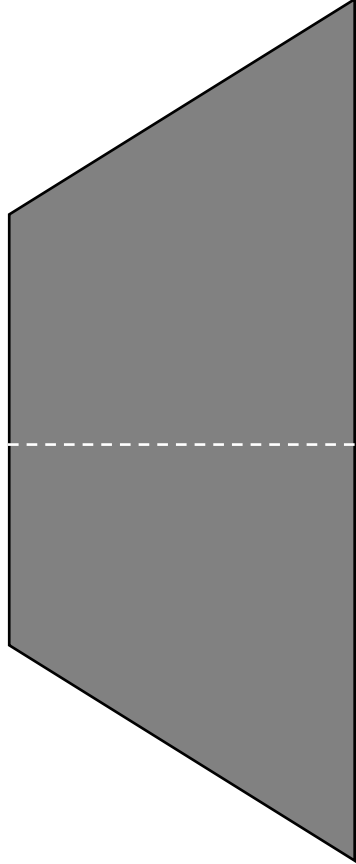

LOW

APPENDIX B

PRESSURE ALTITUDE	
ISA	1013
Minus QNH	
Result	+
	-
Ft / hPa	X 27
Result	+
	-
Airfield Elevation	
PA	

Known Quantities (examples only)

Departure	Temp	Elev	P Alt	Slope	Wind T	Var	Wind M	Rwy	H/wind	X/wind	Distance required	Distance available
						-20						
Destination										15 max		

FUEL			
	Time	Litres	Weight
A-B			
10% Cont.			
Reserve	As approp	19	30
Dep/App Allow			
Unusable		6	
Min Fuel Reqd			
Dipped Fuel			
Burn Off			

Note: Unusable fuel included in A/C empty weight

Weight and Balance				
	Weight	Arm	Moment	Maximum
A/C Empty Weight				
Pilot and pax		39		
Fuel		42		
Bags Area 1		64		140
Bags Area 2		84		20
T/O Total				1670
Burn Off		42		
Ldg Weight				1670

AIRCRAFT TYPE

(Date of last revision)

Known Quantities (examples only)

CONVERSION FACTORS	
Litres to lbs	X 1.58
US Gal to lbs	X 6
IMP Gal to lbs	X 7.2
Lbs to Kg	X 0.453592
Inches to cm	X 2.54
Cm to inches	X 0.3937
Feet to metres	X 0.3048
Metres to feet	X 3.2808

Acknowledgments

The Civil Aviation Authority of New Zealand has prepared this Flight Instructor's Guide.

Assistance was provided by the RNZAC Instructors' Council and the Aviation Industry Association. Input was also received from Aviation Services Limited.

Where no other reference is cited, this document draws heavily on the information provided in the Australian Civil Aviation and US Federal Aviation Administration's Flight Instructor Handbooks, and their permission to reproduce that information is gratefully acknowledged.

Thank you to all those who have contributed.

References

- AC 60-14 (1977). Aviation instructor's handbook. U.S. Department of Transportation, Federal Aviation Administration.
- AC61-1 (1992). Advisory Circular. Civil Aviation Authority of New Zealand. Lower Hutt: New Zealand Government Print.
- Aeronautical Information Publication (AIP). 1996. Planning manual: OPS section. Wellington: Aviation Publishing.
- Anandam, K. (1986). Technology for education: Promises and problems. In G.H. Vogel (Ed.), Advances in instructional technology. (pp.65-72). San Francisco: Jossey-Bass.
- Anderson, R.C., & Faust, G.W. (1973). Educational psychology: The science of instruction and learning. New York: Dodd, Mead.
- Anderson, R.C., Reynolds, R.E., Schallert, D.L., & Goetz, E.T. (1977). Frameworks for comprehending discourse. American Educational Research Journal, 14 367-381.
- Ausubel, D.P. (1968). Educational psychology: A cognitive view. New York: Holt, Rinehart & Winston.
- Baker, E.L., & O'Neil, H.F., Jr. (1987). Assessing instructional outcomes. In R.M. Gagne (Ed.), Instructional technology: Foundations. (pp.343-377). Hillsdale: Lawrence Erlbaum Associates.
- Berlyne, D.E. (1970). Attention as a problem in behaviour theory. In D.I. Mostofsky (Ed.), Attention: Contemporary theory and analysis. (pp.25-49). New York: Appleton-Century-Crofts.
- Bovy, R.C. (1981). Successful instructional methods: A cognitive information processing approach. Educational Communication and Technology Journal, 29 203-217.
- Briggs, L.J., & Wager, W.W. (1981). Handbook of procedures for the design of instruction. Englewood Cliffs: Educational Technology.
- Brown, G., & Atkins, M. (1991). Effective teaching in higher education. London: Routledge.
- Bunderson, C.V., & Inouye, D.K. (1987). The evolution of computer-aided educational delivery systems. In R.M. Gagne (Ed.), Instructional technology: Foundations. (pp.283-318). Hillsdale: Lawrence Erlbaum Associates.
- CAA Australia (Rev5/88) Flight instructor's manual.
- Campbell, R.D. (1994). Flight instructors manual. Surrey: The Campbell Partnership.
- Cannon, R. (1992). Lecturing. (2nd ed.). Campbelltown: HERDSA.
- Civil Aviation Rules. (1997). Part 91: General operating and flight rules. Wellington: Publishing Solutions.
- Craik, F.I.M. & Lockhart, R.S. (1993). Levels of processing: A framework for memory research. In P.E. Morris & M.A. Conway (Eds.), The psychology of memory, Vol. 1. (pp.268-281). Cambridge: University Press.
- Cronbach, L.J. (1980). Toward reform of program evaluation. San Francisco: Jossey-Bass.

- DeCecco, J.P., & Crawford, W.R. (1974). Psychology of learning and instruction: Educational psychology. Englewood Cliffs: Prentice Hall.
- Degani, A., & Wiener, E.L. (1990). Human factors of flight-deck checklists: The normal checklist. California: NASA.
- Dewey, J. (1938). Experience and education. New York: Macmillan.
- Elshaw, C. (1993). Preparing better flight instructors. In R.A. Telfer (Ed.), Aviation instruction and training (pp.253-270). Hants: Ashgate.
- Ewing, R.L. (1993). Aviation medicine and other human factors for pilots. Auckland: David Ling.
- Ewing, R.L. (1994). Human factors consultants addresses. In Safe human flight training seminar, compiled by P.L.H. Kidd. Hastings: RNZAC.
- Eysenck, M.W. (1984). A handbook of cognitive psychology. Hillsdale: Lawrence Erlbaum Associates.
- Farquhar, B. (1995). Airborne - The complete pilot. Wellington: Aviation Publishing.
- Fitts, P.M., & Posner, M.I. (1967). Human performance. Monterey: Brooks/Cole.
- Fleming, M.L. (1987). Displays and communication. In R.M. Gagne (Ed.), Instructional technology: Foundations (pp.233-260). Hillsdale: Lawrence Erlbaum Associates.
- Gagne, R.M. (1971). The conditions of learning. (2nd ed.). New York: Holt, Rinehart & Winston.
- Gagne, R.M., & Briggs, L.J. (1979). Principles of instructional design. (2nd ed.). New York: Holt, Rinehart & Winston.
- Gagne, R.M., & Driscoll, M.P. (1988). Essentials of learning for instruction. Englewood Cliffs: Prentice Hall.
- Gagne, R.M., & Glaser, R. (1987). Foundations in learning research. In R.M. Gagne (Ed.) Instructional technology: Foundations (pp.49-83). Hillsdale: Lawrence Erlbaum Associates.
- Gagne, R.M., Wager, W., & Rojas, A. (1991). Planning and authoring computer-assisted instruction lessons. In L.J. Briggs, K.L. Gustafson & M.H. Tillman (Eds.), Instructional design: Principles and applications. (2nd ed.). (pp.211-226). Englewood Cliffs: Educational Technology.
- Gaudry, E. & Spielberger, C.D. (1971). Anxiety and educational achievement. Sydney: John Wiley & Sons.
- George, F.H. (1970). Educational technology: The systems approach and cybernetics. In A.J. Romiszowski (Ed.), A systems approach to education and training (pp.22-33). London: Kogan Page.
- Gibbs, G., Habeshaw, S., & Habeshaw, T. (1988). 53 Interesting things to do in your lectures. (3rd ed.). Bristol: Technical and Educational Services.
- Gronlund, N.E., & Linn, R.L. (1990). Measurement and evaluation in teaching. (6th ed.). New York: Macmillan.

- Hall, K.A. (1983). Content structuring and question asking for computer-based education. Journal of Computer-Based Instruction, 10 1-7.
- Hawkins, F.H. (1993). Human factors in flight. (2nd ed.). Edited by H. Orlady. Hants: Ashgate.
- Howe, M.J.A. (1987). Using cognitive psychology to help students learn how to learn. In Richardson, Eysenck & Piper (Eds.), Student learning: Research in education and cognitive psychology. Milton Keynes: The Society for Research into Higher Education & Open University Press.
- Hunt, L.M. (1994). Instruction and learning in aviation. Palmerston North: Massey University.
- Hunt, E.B., & Poltrock, S.E. (1974) The mechanics of thought. In B.H. Kantowitz (Ed.), Human information processing: Tutorials in performance and cognition. (pp.277-350). New York: John Wiley.
- Kermode, A.C. (1996). Mechanics of flight. (10th ed.). Revised & edited by R.H. Barnard & D.R. Philpott. Essex: Longman.
- Knowles, M.S. (1980). The modern practice of adult education: From pedagogy to andragogy. Chicago: Follett Publishing.
- Knowles, M.S. (1988). The adult learner: A neglected species. Houston: Gulf Publishing.
- Levie, W.H., & Lentz, R. (1982). Effects of text illustrations: A review of research. Educational Communication and Technology Journal, 30 195-232.
- Lumsdaine, A.A., & Glaser, R. (Eds.). (1960). Teaching machines and programmed learning: A source book. Washington, D.C.: National education Association.
- Maslow, A.H. (1970). Motivation and personality. New York: Harper & Row.
- Mager, R.F. (1968). Developing attitude toward learning. Belmont: David S. Lake.
- Mager, R.F. (1984). Preparing instructional objectives. (2nd ed.). Belmont: David S. Lake.
- Mayer, R.E. (1979). Can advance organisers influence meaningful learning? Review of Educational Research, 49 371-383.
- McCombs, B.L. (1988). Motivational skills training: Combining metacognitive, cognitive, and affective learning strategies. In C.E. Weinstein, E.T. Goetz & P.A. Alexander (Eds.), Learning and study strategies (pp.141-169). New York: Academic press.
- McKeachie, W.J. (1988). The need for study strategy training. In C.E. Weinstein, E.T. Goetz & P.A. Alexander (Eds.), Learning and study strategies (pp.3-9). New York: Academic Press.
- McLeish, J. (1968). The lecture method. Cambridge: Heffers.
- Merrill, P.F. (1987). Job and task analysis. In R.M. Gagne (Ed.), Instructional technology: Foundations (pp.141-173). Hillsdale: Lawrence Erlbaum Associates.
- New Zealand Aeronautical Information Publication (NZAIP) (1995). Planning Manual. Wellington: Aviation Publishing.
- New Zealand Aeronautical Information Publication (NZAIP) (1995). Visual Flight Guide. Wellington: Aviation Publishing.

- New Zealand Flight Safety. (1983, August/September). Engine failure after take-off, p.4-8.
- New Zealand Flight Safety. (1983/84, December/January). Emergency evacuation, pp.15-18.
- New Zealand Flight Safety. (1986, December). Engine failure after takeoff, pp.8-10.
- New Zealand Flight Safety. (1986, December). Passengers: Customers, friends or family - look after them, pp.17-19.
- New Zealand Flight Safety. (1987, October). Water and fuel do mix...dangerously!, pp.12-13.
- New Zealand Flight Safety. (1988, June). 178 seconds, pp12-14.
- New Zealand Flight Safety. (1989, June). Engine failure survey, pp.8-10.
- New Zealand Flight Safety. (1991, December). She'll be right?, pp.4-9.
- New Zealand Flight Safety. (1994, June). The impossible turn?, pp.12-14.
- New Zealand Flight Safety. (1994, December). Collision avoidance, pp.4-15.
- New Zealand Flight Safety. (1995, December). The human balance system: A refresher for pilots. pp.6-9.
- O'Hare, D., & Roscoe, S. (1992). Flightdeck performance: The human factor. Ames: Iowa State University Press.
- Okey, J.R. (1991). Procedures of lesson design. In L.J. Briggs, K.L. Gustafson & M.H. Tillman (Eds.), Instructional design: Principles and applications. (2nd ed.). (pp.193-208). Englewood Cliffs: Educational Technology.
- Pallett, E.H.J. (1992). Aircraft instruments & intergrated systems. Essex: Longman Scientific & Technical.
- Popham, W.J., & Baker, E.L. (1970a). Planning an instructional sequence. Englewood Cliffs: Prentice-Hall.
- Popham, W.J., & Baker, E.L. (1970b). Systematic instruction. Englewood Cliffs: Prentice-Hall.
- Reason, J. (1990). Human error. Cambridge: Cambridge University Press.
- Reigeluth, C.M. (1983). Meaningfulness and instruction: Relating what is being learned to what a student knows. Instructional Science, 12 197-218.
- Reinhart, R.O. (1988, December). Fit for flight: The fatigued pilot. Business & Commercial Aviation, p.126.
- Reynolds, J.H., & Glasser, R. (1964). Effects of repetition and spaced review upon retention of a complex learning task. Journal of Educational Psychology, 55 297-308.
- RNZAC Instructor Council. (1994). Safe human flight training seminar: 26-29 April 1994 Wanganui. Compiled by P.L.H. Kidd, chairman. RNZAC: Hastings.
- Salomon, G. (1981). Communication & education: Social and psychological interactions. California: Sage.

- Salomon, G. (1984). Television is "easy" and print is "tough": The differential investment of mental effort in learning as a function of perceptions and attributions. Journal of Educational Psychology, 76 647-658.
- Skinner, B.F. (1958). Teaching machines. Science, 128, pp.969-977.
- Skinner, B.F. (1968). The technology of teaching. New York: Meredith.
- Sligo, F.X. (1988). Effective communication in business. Palmerston North: Software Technology.
- Simuflight (NZ) Ltd. (Eds.). (1995). Aeronautical decision making: A study manual for pilots. Auckland: Simuflight.
- Simuflight (NZ) Ltd. (Eds.). (1996). Aeronautical decision making: A study manual for instructor pilots. Auckland: Simuflight.
- Tagiuri, R. (1974). Effective communication. Harvard: Harvard Business Review Reprint Series.
- Telfer, R.A. (Ed.). (1993). Aviation instruction and training. Hants: Ashgate.
- Telfer, R.A. & Biggs, J. (1988). The psychology of flight training. Ames: Iowa State University Press.
- Trollip, S.R., & Jensen, R.S. (1991). Human factors for general aviation. Englewood: Jeppesen Sanderson Inc.
- Tuckman, B.W. (1985). Evaluating instructional programs. (2nd ed.). Boston: Allyn and Bacon.
- Tuckman, B.W. (1988). Testing for teachers. (2nd ed.). New York: Harcourt Brace Jovanovich.
- Voegel, G.H. (Ed.). (1986). Instructional technology mix: Some considerations. In, Advances in instructional technology (pp.73-82). San Francisco: Jossey-Bass.
- Wager, W.W., & Gagne, R.M. (1987). Designing computer-aided instruction. In D.H. Jonassen (Ed.), Instructional designs for microcomputer courseware. Hillsdale: Lawrence Erlbaum Associates.
- Wickelgren, W.A. (1981). Human learning and memory. Annual review of Psychology, 32 21-52.
- Wickens, C.D., & Flach, J.M. (1988). Information processing. In E.L.Wiener, & D.C. Nagel (Eds.), Human factors in aviation (pp.111-155). San Diego: Academic Press.
- Wittrock, M.C. (1988). A constructive review of research on learning strategies. In C.E. Weinstein, E.T. Goetz & P.A. Alexander (Eds.), Learning and study strategies (pp.287-297). New York: Academic Press.
- Yelon, S.L. (1991). Writing and using instructional objectives. In L.J. Briggs, K.L. Gustafson & M.H. Tillman (Eds.), Instructional design: Principles and applications. (2nd ed.). (pp.75-121). Englewood Cliffs: Educational Technology.

